

FORT TICONDEROGA

ACCESSIBLE VISITOR GUIDE

Students: Helen Fang, Tracy Li, Alex Han

Mentor: Timothy Mullen

Content

1. Overview on Fort Ticonderoga
2. Project Goals and Target Audiences
3. Icon Design Decisions
4. Icon Guidelines
5. Guide Layout Design Decisions
6. Final Deliverables
7. Challenges and Future Work



Fort Ticonderoga

Fort Ticonderoga is a major cultural destination, museum, historic site, and center for learning. Visitors can discover innovative storytelling on a grand scale with guided tours, witness thrilling weapons demonstrations, explore endless outdoor activities, and see the British-occupied fort in the years just before the American Revolution.

4 Major Nodes



Fort Ticonderoga



Carillon Battlefield Hiking Trail

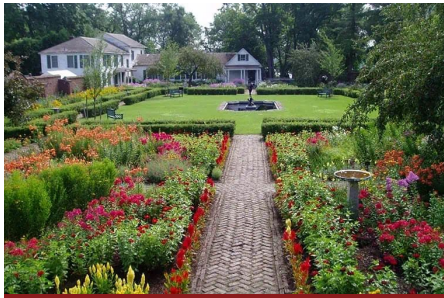

The King's Garden & Pavilion



Heroic Corn Maze

Project Goals

- Redesign of the accessible visitor guide from 2022 (for printed material and the official website).
- Provide sensory notes regarding the ease of accessibility across the historical sites.

Target Audiences

- Guardians of kids with disabilities.
- People with disabilities:
 - visual impairment
 - motor empowerment
 - sensory processing disorder
- All visitors.

It is important to consider the needs of people with different abilities and to provide them with access and sensory information in advance so they can have appropriate expectations for the visit and plan accordingly.

Icon Design Decisions

<p>Sound Levels</p> <p>Loud Moderate to Loud Moderate Quiet</p>	<p>Mobility Conditions</p> <p>Gravel Paved Dirt (Flat) Dirt (Bumpy) Brick (Bumpy)</p>
<p>Touch</p> <p>No Restrictions Restricted</p> <p>Bugs & Animals</p> <p>Not Present Present</p>	<p>Accessibility</p> <p>Accessible Parking Wheelchair Accessible Not Wheelchair Accessible Wheelchair Available</p>
<p>Crowd Levels</p> <p>High Moderate to High Moderate Low</p>	<p>Restrooms</p> <p>Restrooms Accessible Restroom Ramp</p>
<p>Temperature Conditions</p> <p>Hot Natural Moderate to Hot Cool Moderate Controlled</p>	<p>Amenities</p> <p>WiFi Spotty WiFi Cell Service Spotty Cell Service Information Desk</p>
<p>Lighting Conditions</p> <p>Natural Light Dim Light Moderate Light Bright Light Moderate Controlled</p>	<p>Water Fountain</p> <p>Water Fountain Dining/Food Bench Table Alcohol</p>
<p>Smell</p> <p>Low Strong Moderate</p>	<p>Workshops</p> <p>Bug Repellent Life Jacket Workshops Shed</p>

Before

<p>Temperature Condition</p> <p>High Low</p>	<p>Bug</p> <p>Not Presented Presented</p>	<p>Mobility Conditions</p> <p>Gravel Paved</p>	<p>Amenities</p> <p>WiFi Spotty WiFi Cell Service Spotty Cell Service Water Fountain Dining/Food Bench Picnic Table Info Desk Gift Life Jacket Events (Seminar, Workshop) Alcohol Bug Repellent</p>
<p>Crowd Levels</p> <p>High Low</p>	<p>Lighting Conditions</p> <p>Natural Bright Natural Dim Artificial Bright Artificial Dim</p>	<p>Mobility Conditions</p> <p>Dirt - Flat Dirt - Bumpy Brick - Bumpy</p>	
<p>Smell</p> <p>Strong Low</p>	<p>Accessibility</p> <p>Wheelchair Accessible Wheelchair Not Accessible Restroom Accessible Restroom Wheelchair Parking Wheelchair Available Ramp</p>		
<p>Sound Levels</p> <p>Loud Quiet</p>			
<p>Touch</p> <p>No Restrictions Restricted</p>			

After

Icon Design Decisions

- Delete colours and create black & white icons to increase readability and accessibility
- Unify the style
 - stroke weight, filled, corner radius
- Redesign some of the icons to be more clear and recognizable
- Use a more active version for wheelchairs
- The fort chose to use the traditional version of the restroom icon

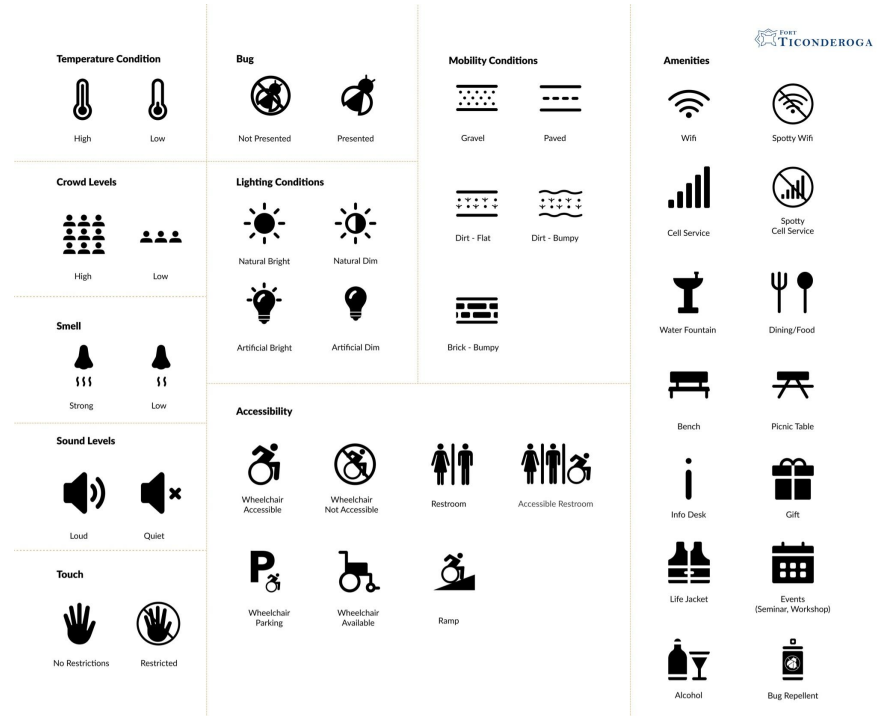

Icon Guidelines



Filled



Background

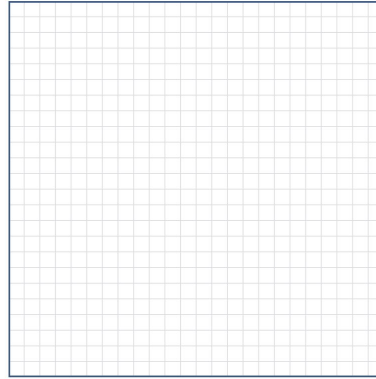

Icon frame: 100px

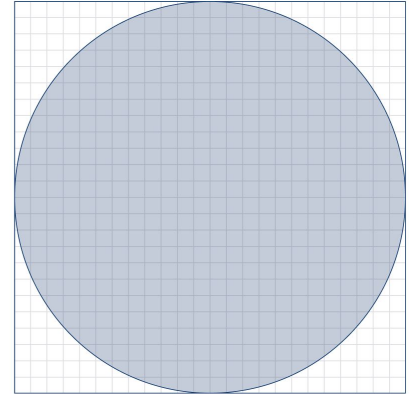

Icon frame: 120px

Icon Guidelines

Stroke Weight

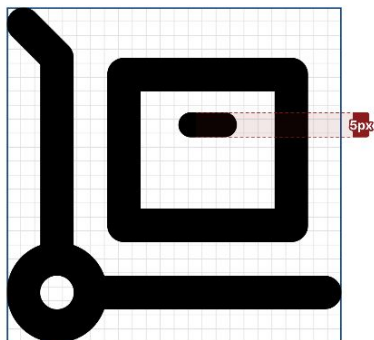
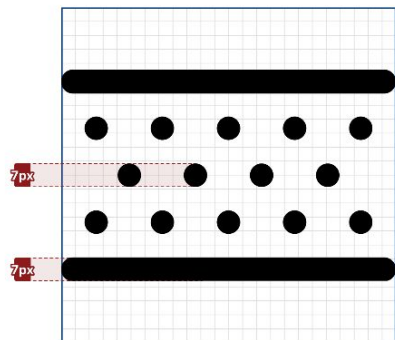

Negative Sapce

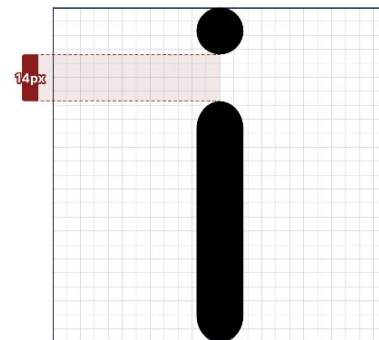
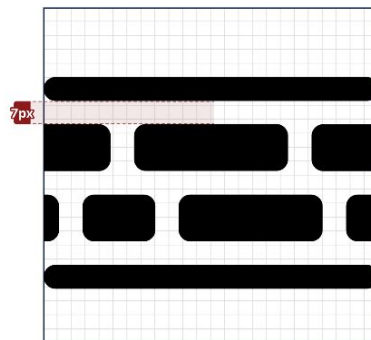

Guide Layout Design Decisions

KING'S GARDEN & PAVILION ACCESSIBILITY & SENSORY GUIDE - II







KING'S GARDEN

A 6-acre historical garden with brick laid paths. Known for historic sustainable agricultural practices.

MOBILITY CONDITIONS		AMENITIES				
 Brick (Bumpy) Uneven Ground	 Resting Benches	 WiFi	 Cell Service			

SOUND	LIGHTING	CROWD	TEMPERATURE	TOUCH	SMELL	BUGS/ ANIMALS
 Quiet to Moderate	 Natural Light	 Low to Moderate	 Natural	 No Restrictions	 Strong *Floral Smells	 Present

Before





The King's Garden & Pavilion

KING'S GARDEN

Lorem ipsum dolor sit amet, consectetur adipiscing elit, sed diam nonummy nibh euismod tincidunt ut laoreet dolore magna aliquam erat volutpat. Ut wisi enim ad minim veniam, quis nostrud exerci tation ullamcorper suscipit lobortis nisl ut aliquip ex ea commodo consequat. Duis autem vel eum irure dolor in hendrerit in valputate velit esse molestie consequat, vel illum dolore eu feugiat nulla facilisis at vero eros et accumsan et justo odio dignissim qui blandit praesent luptatum zzril delenit augue duis dolore te feugiat nulla facilisis.



 Dirt Bumpy



 Wifi



 Cell Service



 Quite

 Natural Bright

 Strong

 Low Crowd Level



 No Restrictions

 Bugs Presented

After

Guide Layout Design Decisions

- Redesigned the layout to be more clear and readable
- Enlarged the image
- Match with the Fort's official website design style
- Adaptable for future online interface or physical prints



FORT
TICONDEROGA

The King's Garden & Pavilion

KING'S GARDEN

Lorem ipsum dolor sit amet, consectetur adipiscing elit, sed diam nonummy nibh euismod tincidunt ut laoreet dolore magna aliquam erat volutpat. Ut wisi enim ad minim veniam, quis nostrud exerci tation ullamcorper suscipit lobortis nisl ut aliquip ex ea commodo consequat. Duis autem vel eum iriure dolor in hendrerit in vulputate velit esse molestie consequat, vel illum dolore eu feugiat nulla facilisis at vero eros et accumsan et justo odio dignissim qui blandit praesent luptatum zzril delenit augue duiis dolore te feugiat nulla facilisis.



Dirt
Bumpy



Wifi



Cell
Service



Quiet



Natural
Bright



Strong



Low
Crowd Level



No
Restrictions



Bugs
Presented

Final Deliverables

Icons

Final Version



Final Version - Black

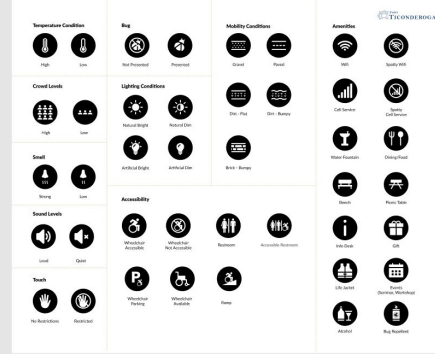

Final Version - Dark Blue



Final Version - Light Blue



Additional Icons

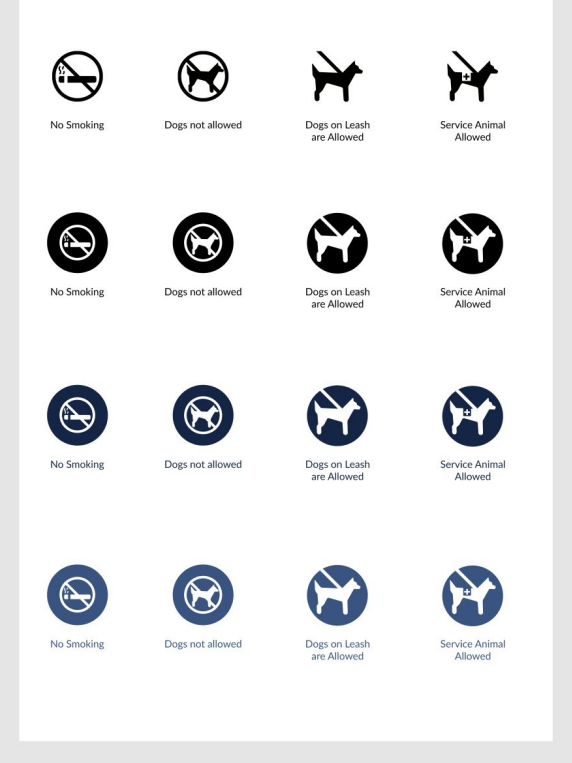

Icons Guideline

Guidelines



Overview

Concept

System icons are designed to be simple, readable and easy to use on both digital interfaces and prints. We aim to create a bold, geometric look in order to achieve consistency across all system icons.

Icon type

The Fort Ticonderoga icon set comes in 2 themes: filled and with background.



Construction

Grid

All icons should be drawn on a 100x100px grid frame. For icons with background, all icons should be drawn on a 120x120px grid frame.

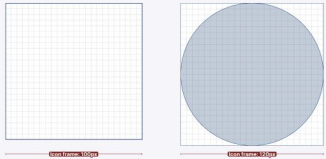

Key shapes

Based on our 100x100px grid, we defined four key shapes: circle, square, vertical rectangle and horizontal rectangle. These fundamental shapes help us maintain consistency across all system icons.

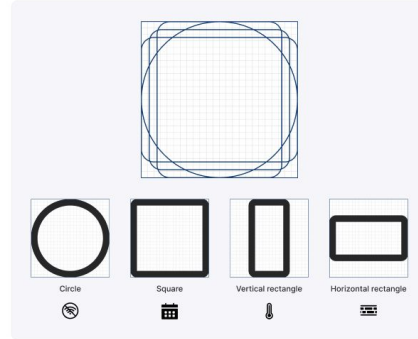

Icon alignment

All icons should be placed at the center of the grid. However, perfectly centered alignment doesn't always work. It's important to optically align them instead to achieve the most balanced placement.

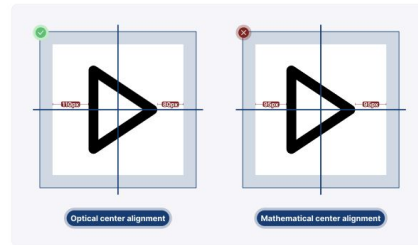

Stroke

Stroke weight & stroke alignment

Maintain the same visual weight by using a 2px centered stroke for all icons.

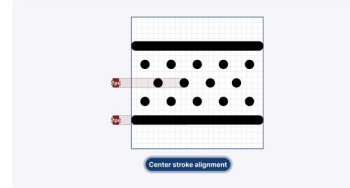

Complex icon adjustment

If a certain system icon has complex details, stroke size should be adjusted to improve visual balance.

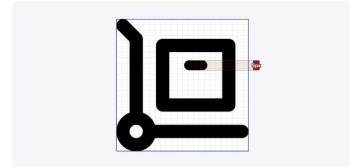

Negative space

When converting a line icon to a filled icon, stroke size may be adjusted to create a stronger contrast and emphasis on the primary symbol.

For example, in the below icon: Exclamation-circle (Filled), the stroke size of the exclamation mark is adjusted from 2px to 2.5px.

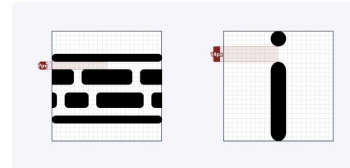

End caps

Use rounded end caps.

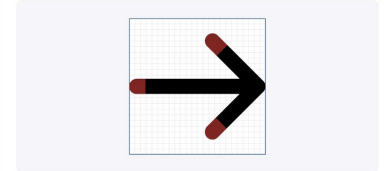

Corner radius

Icons are constructed based on stroke alignments and stroke width. The inner corner radius is 0px, and outer corner radius is 3.5px throughout all icons. To further understand this, please use the following examples:

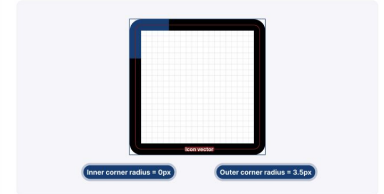

Off icon

Slashes should go from top left to bottom right and icons with rounded background should scale up the stroke size.

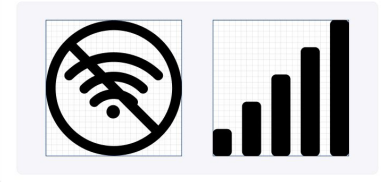

Accessibility Guide

Cover1



Cover1



OVERALL NOTE...



THANK YOU & WELCOME

PLANNING YOUR VISIT

OVERALL ACCESSIBILITY & SENSORY NOTES

AMENITIES & SERVICES

icon guide 7



icon guide 8



icon guide 9



PARKING LOT



BOATHOUSE



PELL FAMILY CE...



CARILLON BOAT...



CARILLON BOAT



PAVILION



King's Garden



GREENHOUSE



DEMONSTRATIO...



MARS EDUCATI...



SOLDIER'S BARR...



OFFICER'S BARR...



HEROIC CORN ...



CARILLON BATT...



PARKING LOT



LOG HOUSE (W...



AMERICA'S FOR...



MUSEUM STORE



PARADE GROUND



Website

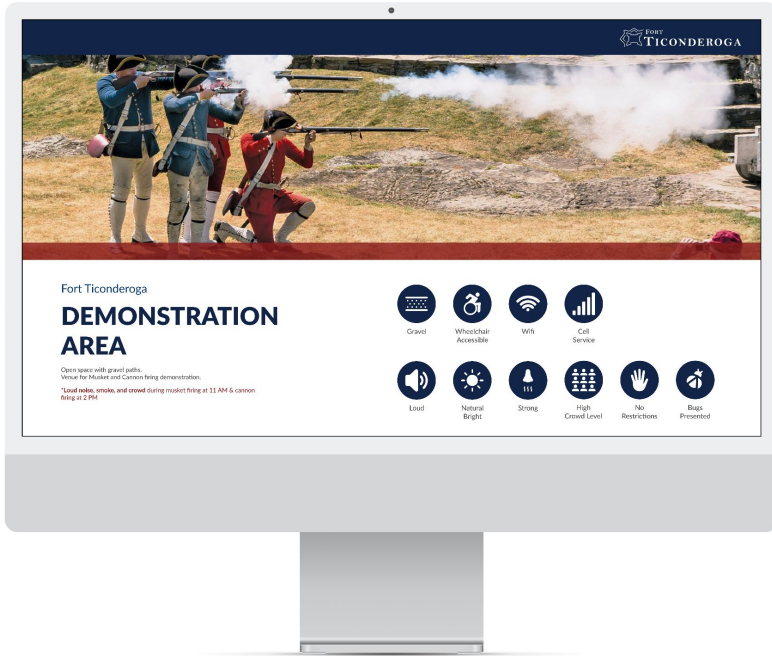

Printed Guide



Challenges

- It's impossible to create one kind of classification that works for everyone.
- On some occasions, word descriptions can be ambiguous and subject to the interpretation of individuals
- Hard to collect information at the site.

Future Work

- Finalize both the digital version and printed version of the accessibility guide.
- Start to do usability testing within incoming visitors after reopening on May 6th.

Thank you!