



My Beat: Health Monitoring Device

Electrical and Computer Engineering Department

Heart of Kings: Michael Moore, Geoffrey Cunningham, Manuel Swingler, Quadre Carter
Advisor: Dr. Doss

DESIGN PROBLEM

Problem Statement

- Inappropriate Sinus Tachycardia (IST) is a condition that will increase one's heart rate dramatically. This happens even if the person isn't doing anything strenuous
- The customer wants the device to be non-intrusive, light/mobile, cost-efficient, and able to keep up with rapid data change
- insert constraints

Design Objective

- Design a device that is non-intrusive, cost-efficient and able to keep up with updating data

Design Criteria/Engineering Requirements

- Sensors should consist of touch based sensors
- Product should not exceed 3"x3"x2"
- Data should send continuously in under 5 minutes

DESIGN ARCHITECTURE

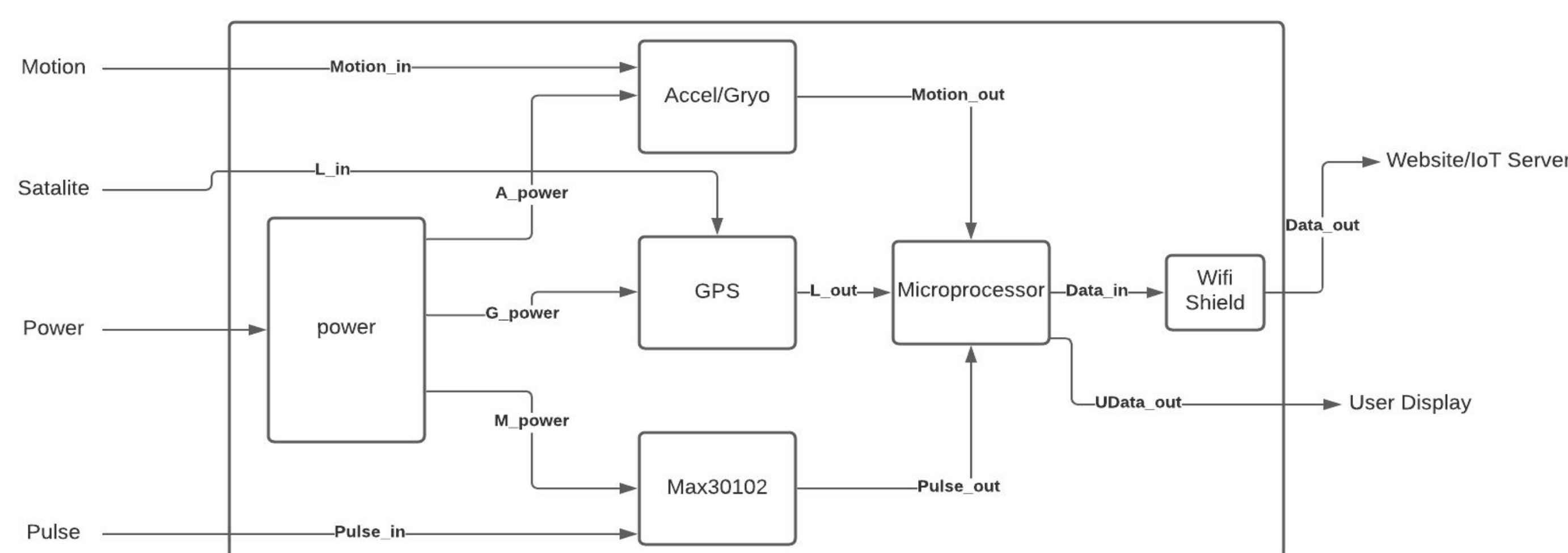

Figure 1. The image above shows the Level 1 Block Diagram

DESIGN IMPLEMENTATION

- Modeling, building, testing the solution
- Diagrams/plans associated with the solution
- Describe how arrived at the solution

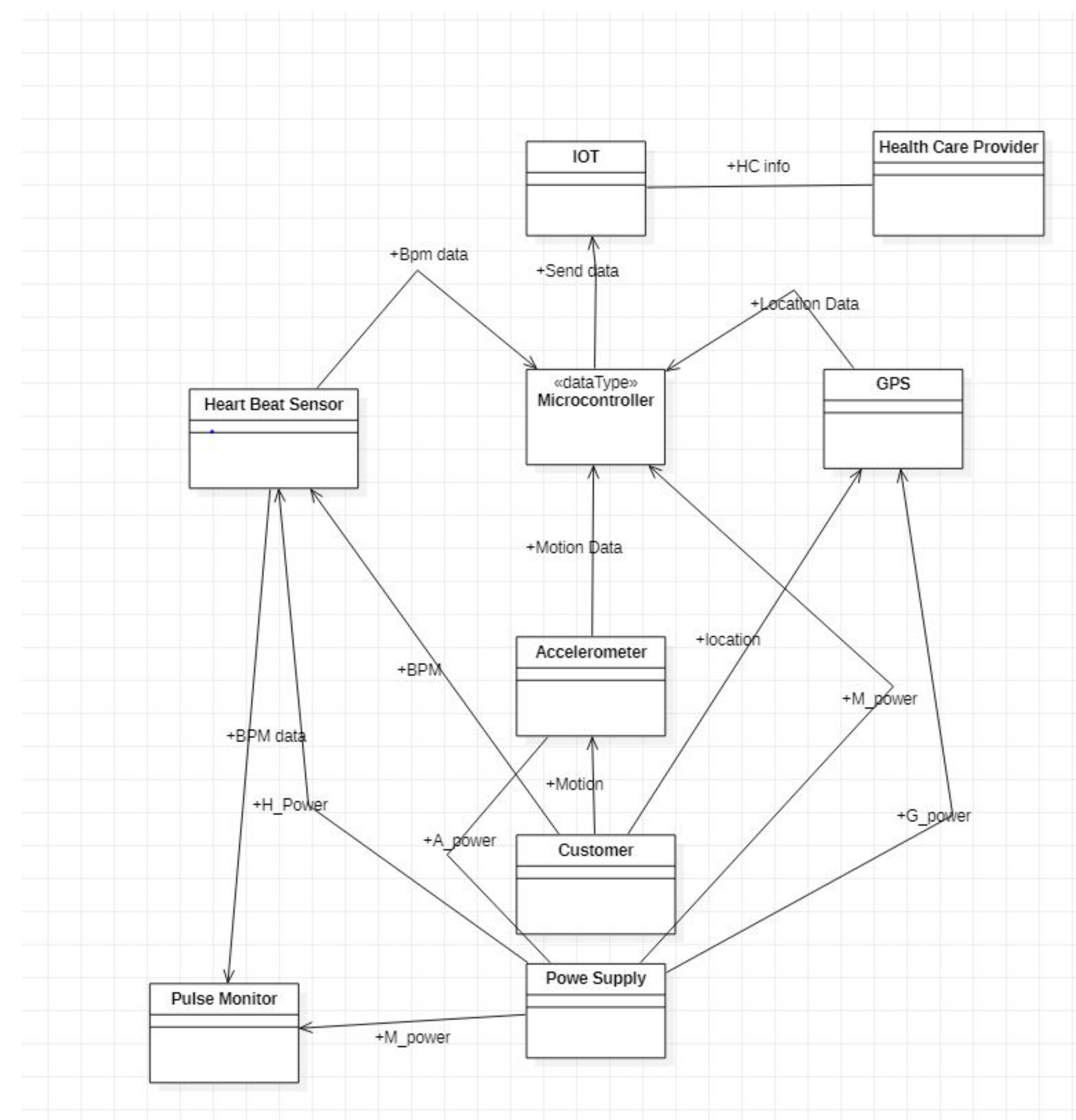

Figure 2. Detailed Design for the Project

TEST RESULTS



Figure 3. Test Data Showing How Well Engineering Requirements and Constrains were Met

Final Project Prototype

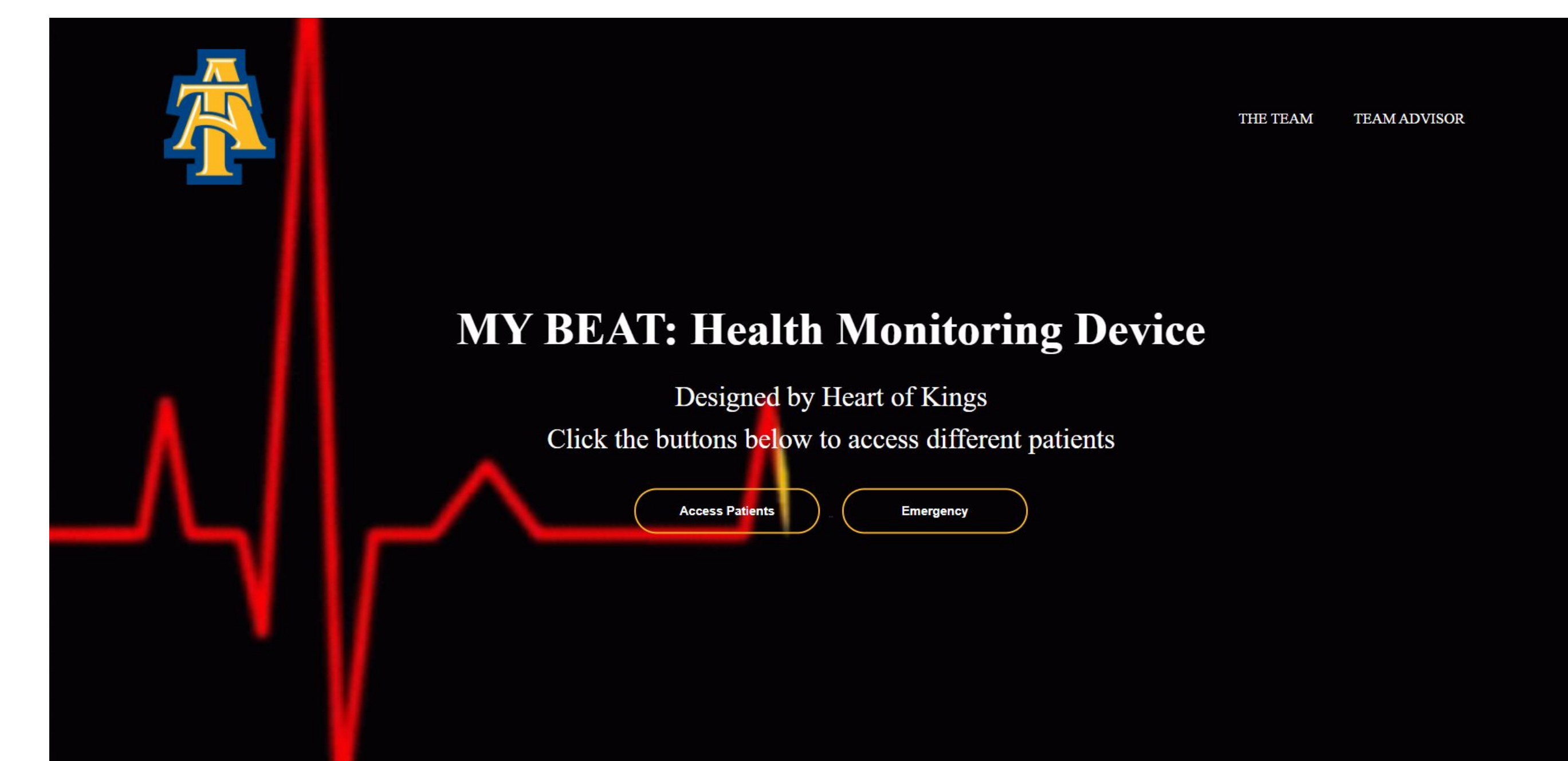

DISCUSSION/CONCLUSION

- These results suggest... that our sensors was able to capture the necessary information and remain unintrusive
- This development is important because (what was learned?) Optimizing the more important aspects of our project
- Future development should focus (improvements?) On a more stable connection