



SAP Easy Access



- Favorites
- ▼ SAP Menu
 - ▶ Office
 - ▶ Cross-Application Components
 - ▶ Logistics
 - ▶ Accounting
 - ▶ Human Resources
 - ▶ Information Systems
 - ▶ Tools
 - ▶ WebClient UI Framework

SAP Material Management
Purchasing
Table KNOV
Document Condition Number

SAP

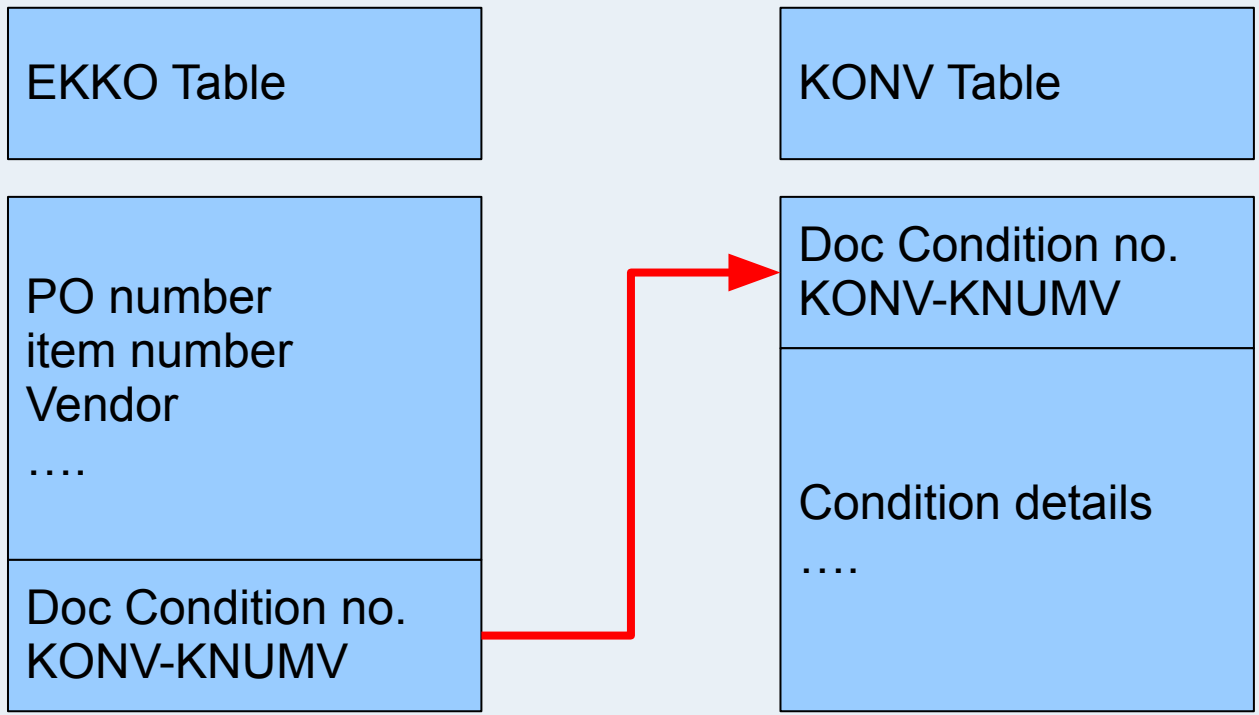

SAP uses the KONV-KNUMV field (Doc Condition no.) as a key stored in EKKO Table so that the details Pricing Conditions are read from the KNOV Table
The Doc Condition no. is generated whenever a PO is created. Doc Condition no.s are generated for each PO item



Display Vendor: Purchasing data

Sub-ranges

Vendor	Z999	city 9
Purchasing Org.	1000	IDES, Deutschland

To illustrate this point, i created a vendor Z999

Conditions

Order currency	EUR	Euro (EMU currency as of 01/01/1999)
Terms of paymnt		
Incoterms		
Minimum order value	0.00	
Schema Group, Vendor	<input type="checkbox"/>	Standard procedure vendor
Pricing Date Control	<input type="checkbox"/>	No Control
Order optim.rest.		

Sales data

Salesperson	
Telephone	
Acc. with vendor	

Control data

<input type="checkbox"/> GR-Based Inv. Verif.	ABC indicator <input type="checkbox"/>	<input type="checkbox"/> RMA Required
<input type="checkbox"/> AutoEvalGRSetmt Del.	ModeOfTrnsprt-Border <input type="checkbox"/>	
<input type="checkbox"/> AutoEvalGRSetmt Ret	Office of entry <input type="checkbox"/>	
<input type="checkbox"/> Acknowledgment Reqd	Sort criterion <input type="checkbox"/>	By VSR sequence number
<input type="checkbox"/> Automatic purchase order	<input type="checkbox"/> Revaluation allowed	
<input type="checkbox"/> Subsequent settlement	<input type="checkbox"/> Grant discount in kind	
<input type="checkbox"/> Subseq. sett. index	<input type="checkbox"/> Relevant for Price Det. (Vendor Hierarchy)	
<input type="checkbox"/> B.vol.comp./ag.nec.		
<input type="checkbox"/> Doc. index active		
<input type="checkbox"/> Returns vendor		
<input type="checkbox"/> Srv.-Based Inv. Ver.		

Default data material

Change Material M999 (Raw material)

Additional Data Org. Levels Check Screen Data

Basic data 2 Purchasing Foreign trade import Purchase order text

Material	M999	material 999
Plant	1000	Hamburg

To illustrate this point, i created a material M999

General Data

Base Unit of Measure	PC	piece(s)	Order Unit	
Purchasing Group	020		Material Group	
Plant-sp.matl status			Valid from	
Tax ind. f. material			Qual.f.FreeGoodsDis.	
Material freight grp			<input type="checkbox"/> Autom. PO	
<input type="checkbox"/> Batch management			OB Management	
			OB ref. matrial	

Purchasing values

Purchasing value key	1	Shipping Instr.	
1st Reminder/Exped.	10 days	Underdel. Tolerance	0.0 percent
2nd Reminder/Exped.	20 days	Overdeliv. Tolerance	0.0 percent
3rd Reminder/Exped.	30 days	Min. Del. Qty in %	0.0 percent
StdValueDelivDateVar	0 days	<input type="checkbox"/> Unltd Overdelivery	<input type="checkbox"/> Acknowledgment Reqd

Other data / manufacturer data

GR Processing Time	days	<input type="checkbox"/> Post to insp. stock	<input type="checkbox"/> Critical Part
Quota arr. usage		<input type="checkbox"/> Source list	JIT Sched. Indicator
Mfr Part Number		Manufact.	



Create Purchase Order

Document Overview On Hold Park Print Preview Messages Personal Setting Save As Template Load from Template

NB Standard PO NB Vendor Z999 Vendor 999 Doc. date 19.09.2016

S..	Itm	A	Material	Short Text	PO Quantity	O...	C	Deliv. Date	Net Price	Curr...	Per	O...	Matl Group	Plnt	Stor. Loc
	10		M999	material 999				19.09.2016	8.99	EUR	1	PC	001	1000	0001
										EUR				1000	0001
										EUR				1000	0001
										EUR				1000	0001
										EUR				1000	0001
										EUR				1000	0001



Item 1 [10] M999 , material 999

I have entered a Gross Price 8.99

View 1 Pricing Elements: Table

N..	CnTy	Name	Amount	Crcy	per	U...	Condition value	Curr.	Status	Num...	OUn	CCon...	Un	Condition value	CdCur	S...
		PBXX Gross Price	8.99	EUR		1PC	899.00	EUR			1PC	1PC		0.00		
		Net incl. disc	8.99	EUR		1PC	899.00	EUR			1PC	1PC		0.00		
		Net incl. tax	8.99	EUR		1PC	899.00	EUR			1PC	1PC		0.00		
		SKT0 Cash Discount	0.000	%			0.00	EUR		0		0		0.00		
		Actual Price	8.99	EUR		1PC	899.00	EUR			1PC	1PC		0.00		

General Table Display

Background Number of Entries All Entries

Table

Purchasing Document Header
 No texts
 Maintain entries

Layout
Maximum no. of hits

check EKKO Table

Selection Criteria

Fld name	O.	Fr. Value	To value	Technical name
Client				MANDT
Purchasing Doc.	<input type="checkbox"/>			EBELN
Company Code	<input type="checkbox"/>			BUKRS
Doc. Category	<input type="checkbox"/>		<input type="checkbox"/>	BSTYP
Document Type	<input type="checkbox"/>		<input type="checkbox"/>	BSART
Control	<input type="checkbox"/>		<input type="checkbox"/>	BSAKZ
Deletion Ind.	<input type="checkbox"/>		<input type="checkbox"/>	LOEKZ
Status	<input type="checkbox"/>		<input type="checkbox"/>	STATU
Created on	<input type="checkbox"/>	19.09.2016		AEDAT
Created by	<input type="checkbox"/>	FROGGY		ERNAM
Item Interval	<input type="checkbox"/>			PINCR
Last Item	<input type="checkbox"/>			LPONR
Vendor	<input type="checkbox"/>			LIFNR
Language	<input type="checkbox"/>			SPRAS
Payt Terms	<input type="checkbox"/>			ZTERM
Payment in	<input type="checkbox"/>			ZBD1T
Payment in	<input type="checkbox"/>			ZBD2T
Payment in	<input type="checkbox"/>			ZBD3T

EKKO: Display of Entries Found



Table to be searched: Purchasing Document Header

Number of hits:

Runtime: Maximum no. of hits:



Purch.Doc.	CoCode	C	Type	Ctl	D S	Created on	Created	ItInt	LItem	Vendor	Language	PayT	Payment in	Payment in	Payment in	Disc.1	Disc.2	POrg	PGr	Crcy	Exch. R
4500017228	1000	F	NB		9	19.09.2016	FROGGY	10	10	1000	EN	ZB01	14	30	45	3.000	2.000	1000	000	EUR	1.000
4500017229	1000	F	NB		9	19.09.2016	FROGGY	10	10	Z999	EN		0	0	0	0.000	0.000	1000	000	EUR	1.000

PO item

Vendor Z999

PO
4500027229
created earlier

EKKO: Display of Entries Found



Table to be searched: Purchasing Document Header

Number of hits:

Runtime: Maximum no. of hits:



Purch.Doc.	Customer	Agmt	Field Not Used	CDI	G	SPlt	Rec.vendor	IncoT	Inco. 2	Targ. Val.	Coll. No.	Doc. condition no.	Procedure	UpdGrp	Inv. Pty	FT no.	Our Ref.	Log.System	SIIn
4500017228								EXW		0.00		1000028227	RM0000	SAP					
4500017229										0.00		1000028228	RM0000	SAP					

Note
 Doc Condition no.
 10000028228
 generated

EKKO table do not store the pricing condition for PBXX but use the Doc Condition no. to locate the condition record details in the KONV table

General Table Display

Background Number of Entries All Entries

Table

Text table

Layout

Maximum no. of hits

Conditions (Transaction Data)

- No texts
- Maintain entries

Selection Criteria

Fld name	O.	Fr. Value	To value	Technical name
Client				MANDT
Doc. condition				KNUMV
Item				KPOSN
Step number				STUNR
Counter				ZAEHK
Application		M		KAPPL
Condition type				KSCHL
CondPricingDate				KDATU
Calculat.type				KRECH
Cond.base value				KAWBT
Amount				
Currency				
Cond.exch.rate				
Pricing unit				
Condition unit				
Numer.for conv.				
Den. for conv.				
Condit.category				

check KONV Table

KONV table stores both Sales Order and Purchase Order Document Condition no. "M" means Purchasing

General Table Display

Background Number of Entries All Entries

Table: KONV
Text table:
Layout:
Maximum no. of hits: 500

Conditions (Transaction Data)
 No texts
 Maintain entries

Selection Criteria

Fld name	O.	Fr. Value	To value	More	Output	Technical name
Client						MANDT
Doc. condition		1000028228			<input checked="" type="checkbox"/>	KNUMV
Item					<input checked="" type="checkbox"/>	KPOSN
Step number					<input checked="" type="checkbox"/>	STUNR
Counter					<input checked="" type="checkbox"/>	ZAEHK
Application		M			<input checked="" type="checkbox"/>	KAPPL
Condition type		PBXX			<input checked="" type="checkbox"/>	KSCHL
CondPricingDate		19.09.2016			<input checked="" type="checkbox"/>	KDATU
Calculat.type					<input checked="" type="checkbox"/>	KRECH
Cond.base value					<input checked="" type="checkbox"/>	KAWRT
Amount					<input checked="" type="checkbox"/>	KBETR
Currency					<input checked="" type="checkbox"/>	WAERS
Cond.exch.rate					<input checked="" type="checkbox"/>	KKURS
Pricing unit					<input checked="" type="checkbox"/>	KPEIN
Condition unit					<input checked="" type="checkbox"/>	KMEIN
Numer. for conv.					<input checked="" type="checkbox"/>	KUMZA
Den. for conv.					<input checked="" type="checkbox"/>	KUMNE
Condit.category					<input checked="" type="checkbox"/>	KNTYP

KONV: Display of Entries Found



Table to be searched: Conditions (Transaction Data)

Number of hits:

Runtime: Maximum no. of hits:



Doc.cond.	Item	Step	Cntr	App	CnTy	CondPrgDt	CalTy	CondBasVal	Amount	Crcy	CondExchRt	per	UoM	NumCCo	CConDe	CdCat	Stat	S	Accr.	InLic	Orig	GrC	CdUpd	AcNo	CondRe
1000028228	10	1	1	M	PBXX	19.09.2016	C	1,000.00	8.99	EUR	1.00000	1	PC	1	1	H					A				

Note the PO Price 8.99 entered earlier

SAP

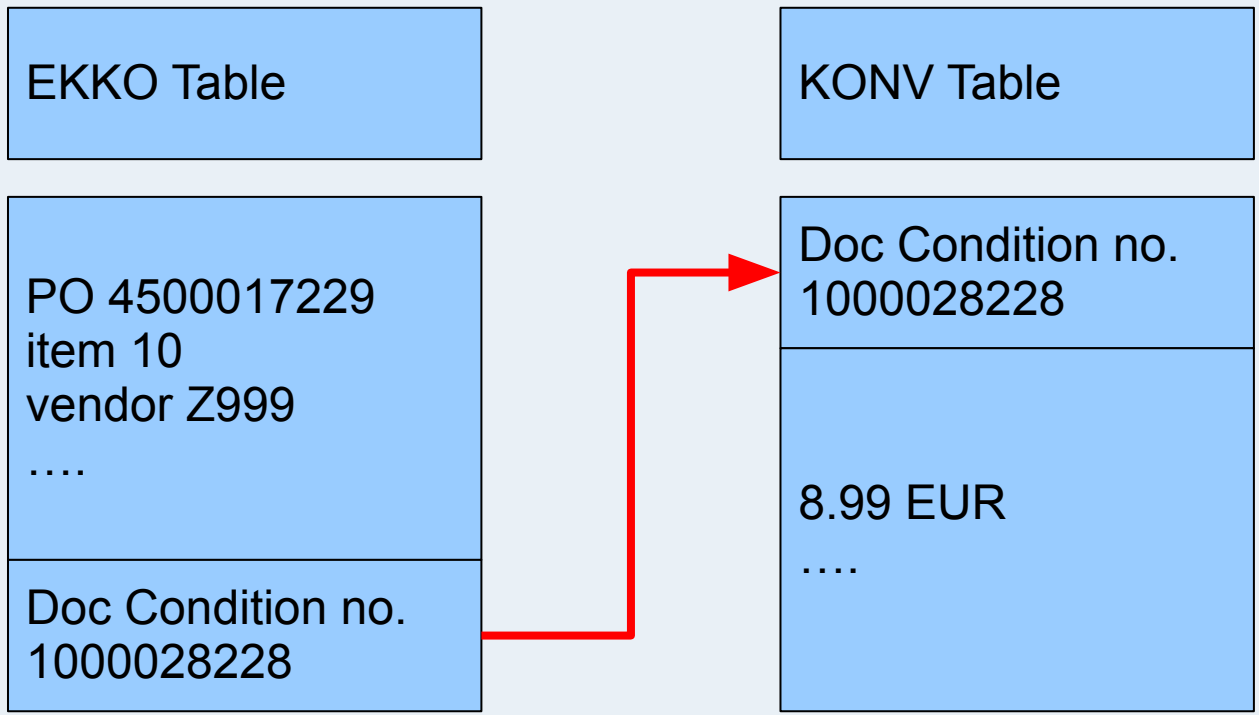

SAP uses the KONV-KNUMV field (Doc Condition no.) as a key stored in EKKO Table so that the details Pricing Conditions are read from the KNOV Table
The Doc Condition no. is generated whenever a PO is created. Doc Condition no.s are generated for each PO item