



**VEHICLE SPEED FROM MOTOR TORQUE**  
**MATLAB project synopsis submitted in partial fulfilment**  
**For the Award of**  
*MASTER CERTIFICATION*  
**In**  
**ELECTRIC VEHICLE NANODEGREE PROGRAM**  
**By**  
*Anshul Kandari*

**DIY guru Education & Research Pt. Ltd**  
**(Impanelled by NEAT, AICTE, Ministry of Education, Gov. of India)**

## Table of Contents

<b>List of Tables</b>	<b>1</b>
<b>List of Figures</b>	<b>2</b>
<b>Chapter 2 Project Description</b>	<b>1</b>
<b>2.1. Objective</b>	<b>1</b>
<b>2.2. Theory</b>	<b>1</b>
<b>2.3. Traction forces</b>	<b>1</b>
<b>2.3.1. Aerodynamic Drag Force</b>	<b>1</b>
<b>2.3.2. Rolling Resistance Force</b>	<b>2</b>
<b>2.3.3. Uphill / Gradient Force</b>	<b>2</b>
<b>2.3.4. Acceleration / Inertia Force</b>	<b>2</b>
<b>2.4. Total traction force (<math>FT</math>)</b>	<b>2</b>
<b>Chapter 3 Required Input Parameters and Calculations</b>	<b>3</b>
<b>3.1. Input parameters</b>	<b>3</b>
<b>3.2. Formula use</b>	<b>3</b>
<b>3.3. Simulink model</b>	<b>4</b>
<b>Chapter 4: Output Parameters</b>	<b>5</b>
<b>Chapter 5 Results and Conclusions</b>	<b>6</b>

# Chapter 1

## List of Tables

Table 1 Specific Parameters

3

## List of Figures

Figure 1 tractive forces free body diagram	1
Figure 2 Simulink Model of Speed Torque Characteristic Model	4
Figure 3 Force Asserted on Vehicle Vs Time Curve	5

## Chapter 2 Project Description

### 2.1. Objective

Develop a Simulink model to display Vehicle Speed and distance covered of EV

### 2.2. Theory

Basically this project deals with calculation range of electric vehicles using motor torque and for this close loop feedback system is used. Hence firstly calculate the vehicle dynamics forces asserted on the vehicle.

### 2.3. Traction forces

- Aerodynamics drag forces ( $F_a$ )
- Rolling resistance forces ( $F_r$ )
- Gradient / uphill forces ( $F_g$ )
- Acceleration / Inertia forces ( $F_i$ )

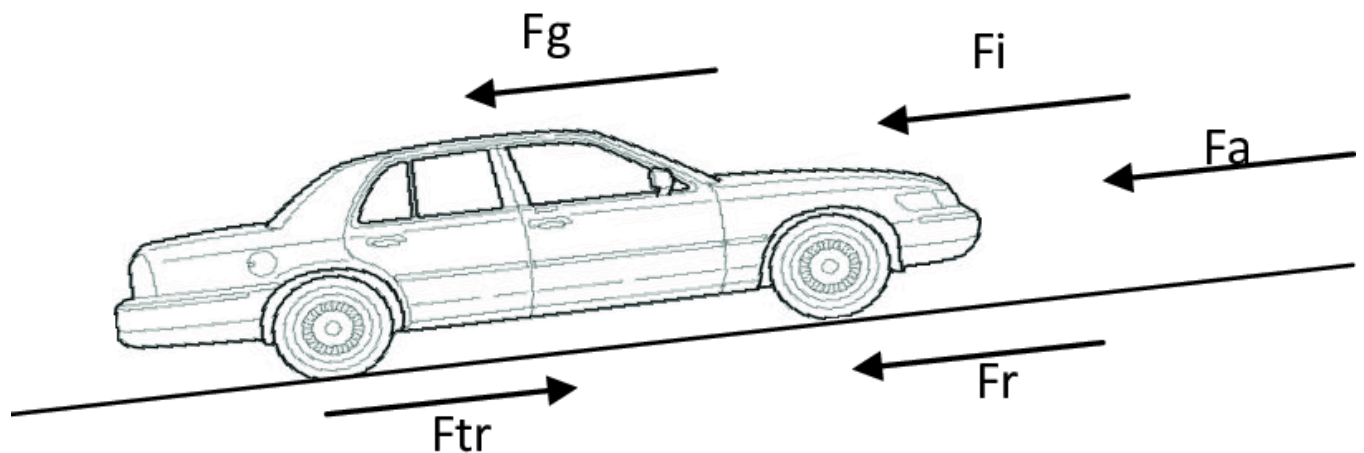

**Figure 1** tractive forces free body diagram

#### 2.3.1. Aerodynamic Drag Force

This forces is acting in frontal part of vehicle due to air resistance in opposite to direction of motion of vehicle. The formula of aerodynamic drag force is as:

$$F_a = \frac{1}{2} \rho A C_d v^2$$

$\rho$  = Density of Air ( $Kg/m^3$ )

$A$  = Frontal Area / Projected Area of Vehicle ( $m^2$ )

$C_d$  = Drag Coefficient of Air

$v$  = Velocity of Vehicle (m/s)

### 2.3.2. Rolling Resistance Force

This force is acting in between road and tire of vehicle in opposite direction of motion of vehicle. The formula of rolling resistance is as:

Case 1:- when vehicle is moving on flat road:

$$F_r = \mu mg$$

Case 2:- when vehicle is moving on incline road:

$$F_r = \mu mg \cos\theta$$

$\mu$  = Rolling resistance coefficient

$m$  = Gross mass of vehicle (kg)

$g$  = Specific gravity value

$\theta$  = angle of inclination / gradient angle

### 2.3.3. Uphill / Gradient Force

This force is acting when vehicle moving on slope road either uphill or downhill. The formula use for this force is as:

$$F_g = mg \sin\theta$$

### 2.3.4. Acceleration / Inertia Force

This force is opposing force acting on opposite direction of motion of vehicle when accelerating the vehicle. The formula use for this force is as:

$$F_i = ma$$

$a$  = Acceleration of vehicle in ( $m/s^2$ )

## 2.4. Total traction force ( $F_T$ )

This force is the net sum of all forces acting on vehicle while moving. The formula of traction force is as:

$$F_T = F_a + F_r + F_g + F_i$$

## Chapter 3 Required Input Parameters and Calculations

### 3.1. Input parameters

Table 1 Specific Parameters

Symbol	About	Values	Units
M	Gross Vehicle Weight	300	Kg
$C_d$	Drag Coefficient	0.5	
A	Frontal Area	1.5	$m^2$
$\mu_r$	Rolling Coefficient	0.015	
r	Effective Radius Of Tire	0.3	m
$\theta$	Gradient Angle	0	
T	Motor Torque	50	Nm

### 3.2. Formula use

- i. **Tractive Force ( $F_T$ ) = Motor Torque (T) / Wheel Radius**
- ii. **Acceleration = Inertia or Force / Mass**
- iii. **Acceleration =  $\frac{d}{dt}$  (Speed)**
- iv. **Speed =  $\frac{d}{dt}$  (Distance)**

### 3.3. Simulink model

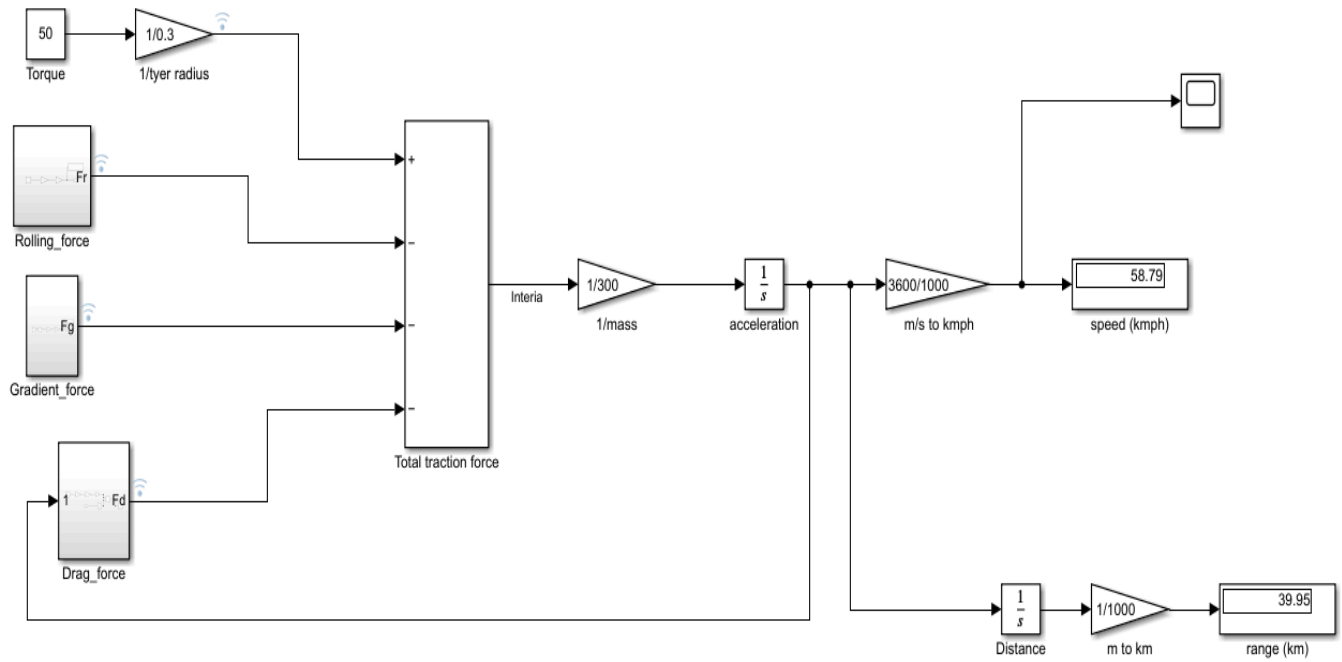
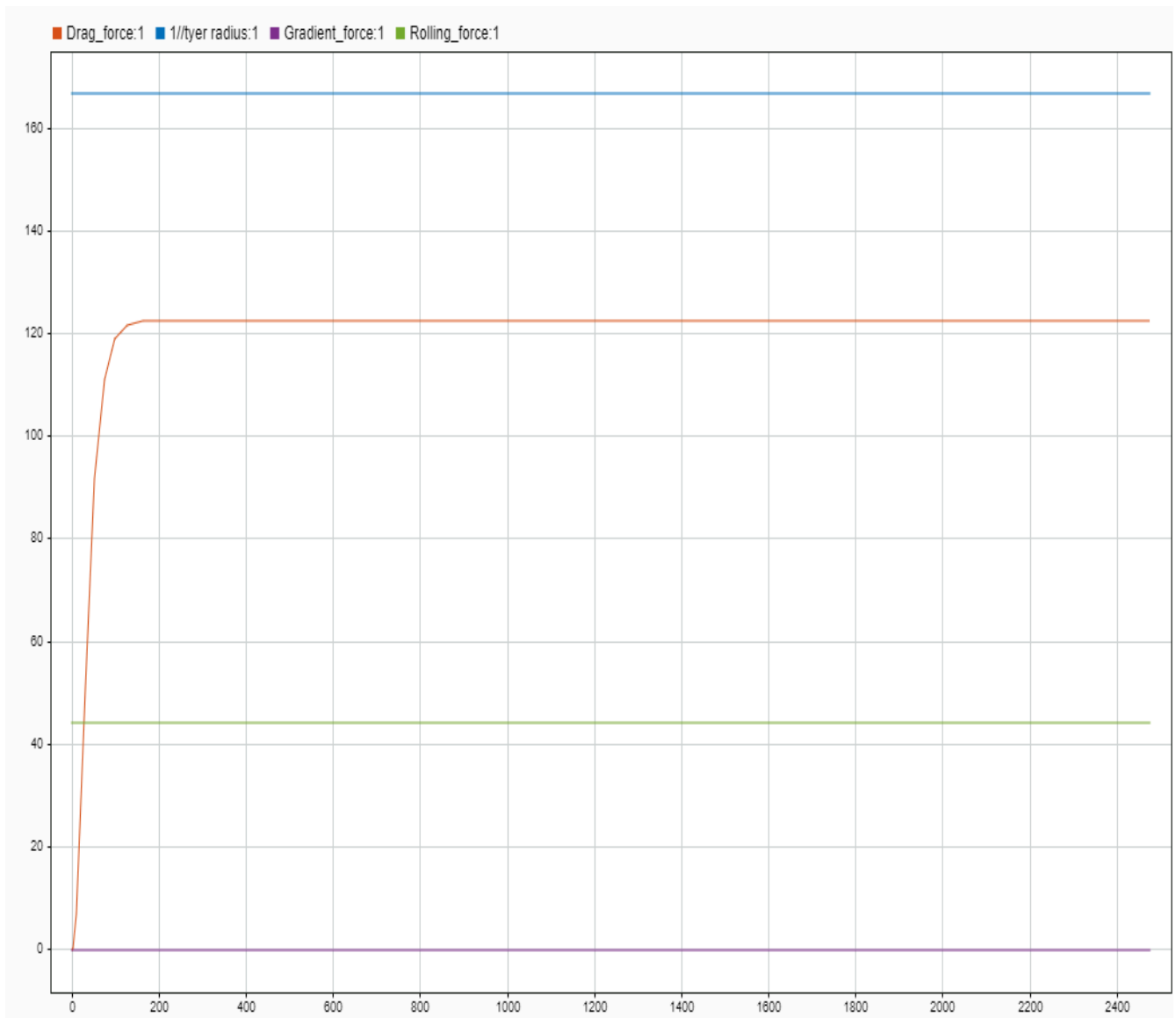

**Figure 2 Simulink Model of Speed Torque Characteristic Model**

4.

## Chapter 4: Output Parameters

### Output



**Figure 3 Force Asserted on Vehicle Vs Time Curve**

## Chapter 5 Results and Conclusions

Hence by analysing the above Simulink model the following result has been drawn:-

- i. Drag force is come out to be **122.5 N**.
- ii. Rolling resistance force is **44.14 N**.
- iii. Gradient force is **0 N**.
- iv. Top speed nearly **60 kmph**
- v. Total distance covered is **40 km**

And by analysis of above graph we can conclude that drag force is dependent on speed of vehicle while other forces such as rolling force, gradient force is not dependent upon speed.