



PROJECT BASED LEARNING SYNOPSIS

On

Design and Analysis of Two Wheeler Battery Pack

DATE: 19/11/2022

ANSHUL KANDARI

Table of Contents

List of Figure	1
LIST OF TABLE	2
Chapter 1: Details of the Team members	1
Chapter 2: Project Description	2
2.1. Traction forces	2
2.1.1. Aerodynamic Drag Force	2
2.1.2. Rolling Resistance Force	3
2.1.3. Uphill / Gradient Force	3
2.1.4. Acceleration / Inertia Force	3
2.2. Total traction force (FT)	3
2.3. Traction power (Pt)	4
2.4. Wheel / Traction Torque (Tt)	4
2.5. Wheel speed (Nv)	4
2.6. Energy consumption	4
2.6.1. Energy consumed in one hours (kWh)	4
2.6.2. Energy consumption for one km (kWh/km)	4
2.6.3. Energy consumption for range (kWh)	5
2.7. Motor calculation	5
2.7.1. Motor power (Pt)	5
2.8. Battery Pack Calculation	5
2.8.1. Energy density of battery Pack (Ah)	5
2.8.2. Number of cells in series in battery pack (Ns)	5
2.8.3. Number of cells in parallel in battery pack (Np)	5
2.8.4. Weight of battery pack (W)	5
Chapter 3: Required Input Parameters and Calculations	6
MATLAB script	6
Simulation Model of Battery Pack	7
Steps of battery pack calculations	8
Chapter 4: Output Parameters	13
Chapter 5: Results & conclusions	16

FIGURE 1 TRACTIVE FORCES FREE BODY DIAGRAM

2

FIGURE 2 SIMULINK MODEL OF BATTERY PACK

7

**LIST OF
FIGURE**

TABLE 1 SPECIFICATION OF TWO WHEELER ELECTRIC SCOOTER

6

Chapter 1: Details of the Team members

S.no	Name	Engineering Field	Occupation	Role in Project
1	Anshul Kandari	Electrical engineering	Student	Made Whole Project Alone

Chapter 2: Project Description

Basically this project deal with calculation of battery pack of two wheeler electric scooter. Hence firstly calculate the vehicle dynamics forces asserted on the vehicle.

2.1. Traction forces

- Aerodynamics drag forces (F_a)
- Rolling resistance forces (F_r)
- Gradient / uphill forces (F_g)
- Acceleration / Inertia forces (F_i)

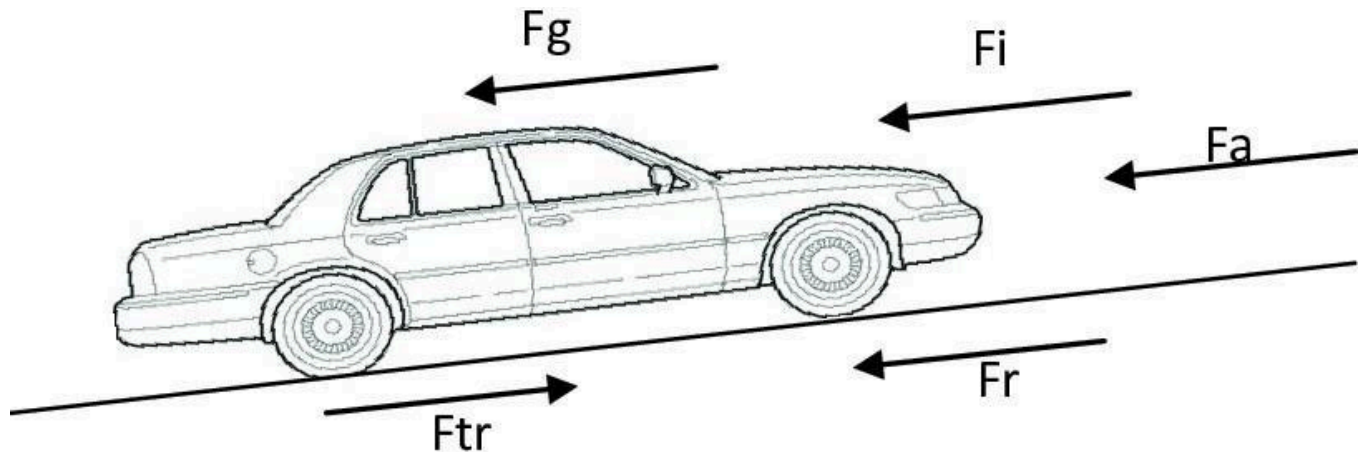

Figure 1 tractive forces free body diagram

2.1.1. Aerodynamic Drag Force

This forces is acting in frontal part of vehicle due to air resistance in opposite to direction of motion of vehicle. The formula of aerodynamic drag force is as:

$$F_a = \frac{1}{2} \rho A C_d v^2$$

ρ = Density of Air (Kg/m^3)

A = Frontal Area / Projected Area of Vehicle (m^2)

C_d = Drag Coefficient of Air

v = Velocity of Vehicle (m/s)

2.1.2. Rolling Resistance Force

This force is acting in between road and tire of vehicle in opposite direction of motion of vehicle. The formula of rolling resistance is as:

Case 1:- when vehicle is moving on flat road:

$$F_r = \mu mg$$

Case 2:- when vehicle is moving on incline road:

$$F_r = \mu mg \cos \theta$$

μ = Rolling resistance coefficient

m = Gross mass of vehicle (kg)

g = Specific gravity value

θ = angle of inclination / gradient angle

2.1.3. Uphill / Gradient Force

This force is acting when vehicle moving on slope road either uphill or downhill. The formula use for this force is as:

$$F_g = mg \sin \theta$$

2.1.4. Acceleration / Inertia Force

This force is opposing force acting on opposite direction of motion of vehicle when accelerating the vehicle. The formula use for this force is as:

$$F_i = ma$$

a = Acceleration of vehicle in (m/s^2)

2.2. Total traction force (F_T)

This force is the net sum of all forces acting on vehicle while moving. The formula of traction force is as:

$$F_T = F_a + F_r + F_g + F_i$$

2.3. Traction power (P_t)

The vehicle needs traction power applied to it to move and accelerate. Hence this power in EV's comes from battery through motor & its controllers. The traction power creates a force on the vehicle to move forward.

$$P_t = \frac{F_T * V}{3600}$$

Here,

V = Speed of Vehicle in (kmph)

P_t = Traction Power in kW

2.4. Wheel / Traction Torque (T_t)

It is the torque produced by traction force on vehicle wheel. The formula used for as:

$$T_t = F_T * r_d$$

r_d = wheel effective radius in (m)

T_t = Traction Torque in (Nm)

2.5. Wheel speed (N_v)

It is the speed of wheel in rpm

$$N_v = \frac{9.55 * V}{r_d}$$

2.6. Energy consumption

The energy consumption of vehicle is product of power consumed and time.

2.6.1. Energy consumed in one hour (kWh)

Power consumed by vehicle when running for one hour then it is called as Energy consumption in kWh.

$$E = P_t / \text{hr}$$

2.6.2. Energy consumption for one km (kWh/km)

Energy required for running vehicle per km distance.

$$E_c = E/\text{km}$$

2.6.3. Energy consumption for range (kWh)

Total energy consumed by vehicle over whole range.

$$E_{C \text{ range}} = E_c * R$$

R = Range of vehicle in (km)

2.7. Motor calculation

2.7.1. Motor power (Pt)

Total power consumed by motor to run the vehicle

$$P_t = V * I$$

V = Motor Voltage in (Volt)

I = Motor Current in (A)

2.8. Battery Pack Calculation

2.8.1. Energy density of battery Pack (Ah)

Energy density of whole battery pack is given by formulas as:

$$E_d = \frac{E_{C \text{ range}}}{V}$$

2.8.2. Number of cells in series in battery pack (N_s)

The number of cells connected in series in battery pack

$$N_s = V / V_c$$

V_c = Nominal Voltage of Cell (V)

2.8.3. Number of cells in parallel in battery pack (N_p)

The number of cells connected in parallel in battery pack.

$$N_p = I / I_c$$

I_c = Nominal current of cell (A)

2.8.4. Weight of battery pack (W)

$$W = N_s * N_p * W_c$$

Chapter 3: Required Input Parameters and Calculations

Considering two wheeler electric vehicle having given specification as below:

Table 1 Specification of Two Wheeler Electric Scooter

Symbols	About	Direct values		Conversion values	
		Values	units	Values	units
f_r	Coefficient of Rolling Resistance	0.01	No Unit	0.01	
M	Mass of the Vehicle (GVM)	232	Kg	232	
g	Acceleration due to gravity	9.81	m/s^2		
α	Gradient angle	0	$^\circ$	0	radian
ρ	Density	1.225	kg/m^3	1.225	
C_d	Coefficient of Drag	0.6	No Unit	0.6	
A_f	Frontal Area	0.5	m^2	0.5	web
v	Velocity of the Vehicle	80	kmph	22.222	m/s
v_m	Velocity of the Wind	14	kmph	3.889	m/s
η	Power Train Efficiency	90	%	0.9	
	Diameter of the Tire	12	inch	0.3048	m
r_d	effective radius of tire	0.1524	m		
G	Gear Ratio of Power Train	1.9	No Unit		
R	Range of Travel distance required	150	km		
	Motor Controller Efficiency	0.9			
η_m	Motor efficiency	0.9			
V	Motor Voltage	48	V		

MATLAB script

```

% input parameters
d=1.225; % air density in kg/m^3
A=0.5; % Frontal area in m^2
mu=0.01; % rolling resistance
cd=0.6; % drag coeff.
r=0.1524; % wheel radius in m
m=232; % gross weight of vehicle in kg
Nu=0.90; % motor efficiency
Q=0; % gradient angle in 'radian'
range=150;% vehicle range in km
V=80; % Top speed of vehicle in 'Kmph'
Vw=14; % velocity of wind in 'kmph'
G=1.9; % gear ratio of power train
Vm=48; % voltage of motor
Vb=48; % Battery pack voltage in 'Volt' Vc=3.7;
% Nominal voltage of cell in 'Volt' Ic=3.6; %

```

```
Nominal current of cell in 'A' WC=0.045; %  
weight of cell in 'kg'  
a=1; % acceleration in 'm/s^2'
```

Simulation Model of Battery Pack

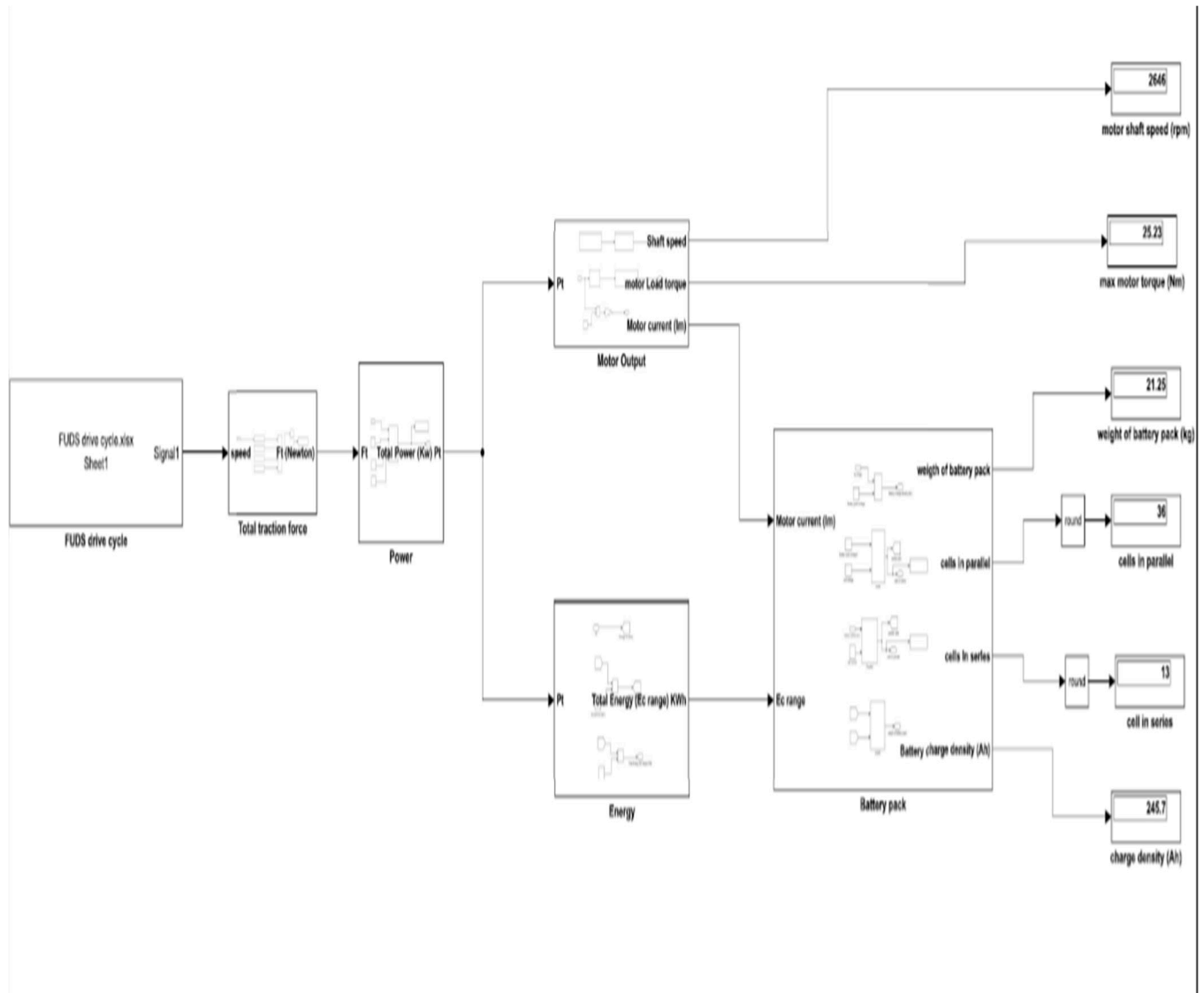
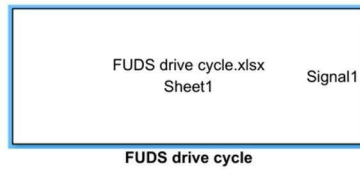

Figure 2 Simulink model of battery pack

Steps of battery pack calculations

- Using *from Spreadsheet* block attach the FUDS drive cycle.



- Now calculate traction force using subsystem model.

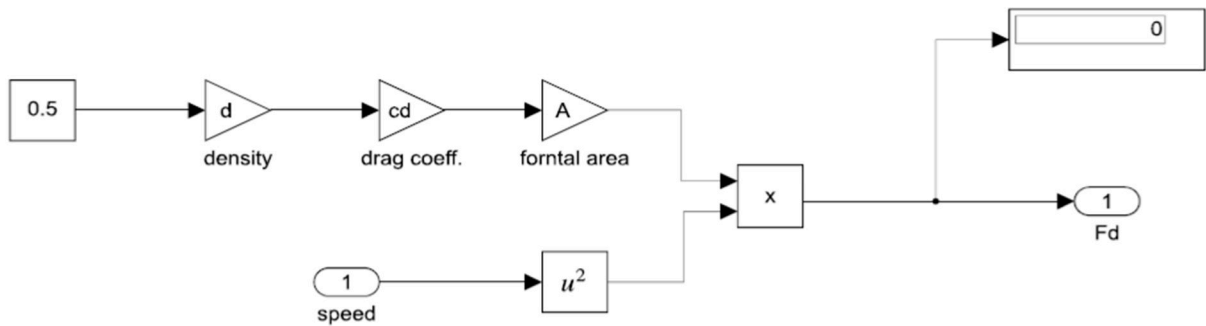
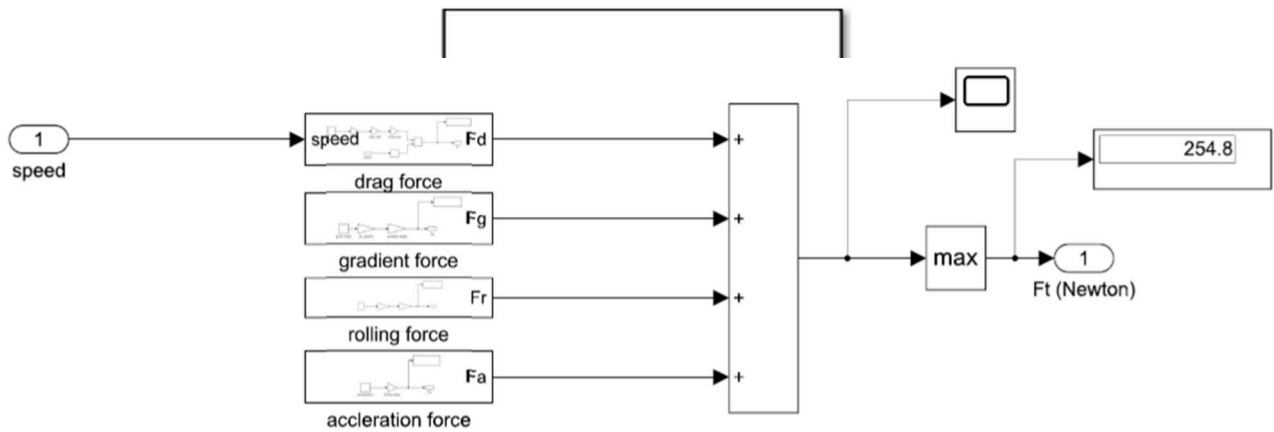

Drag force

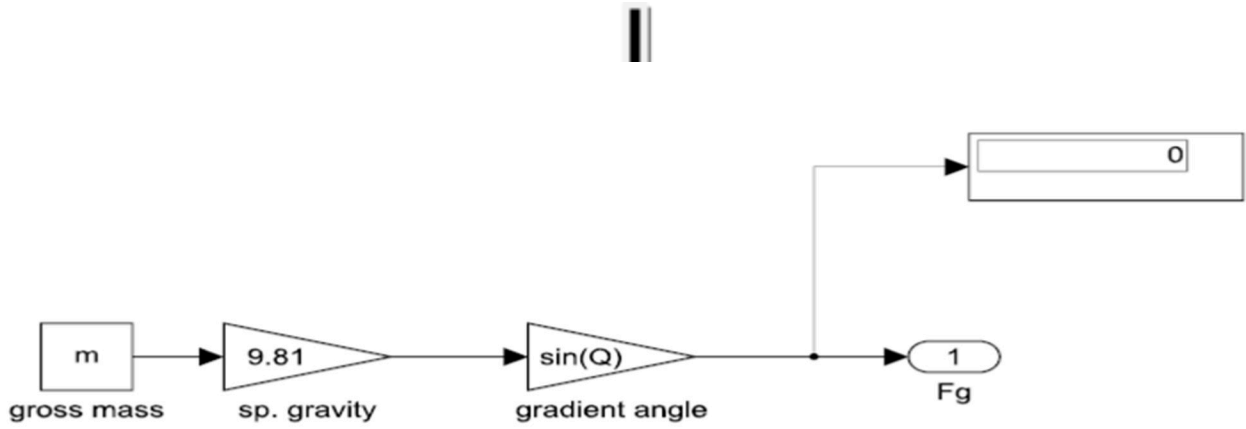

Gradient force

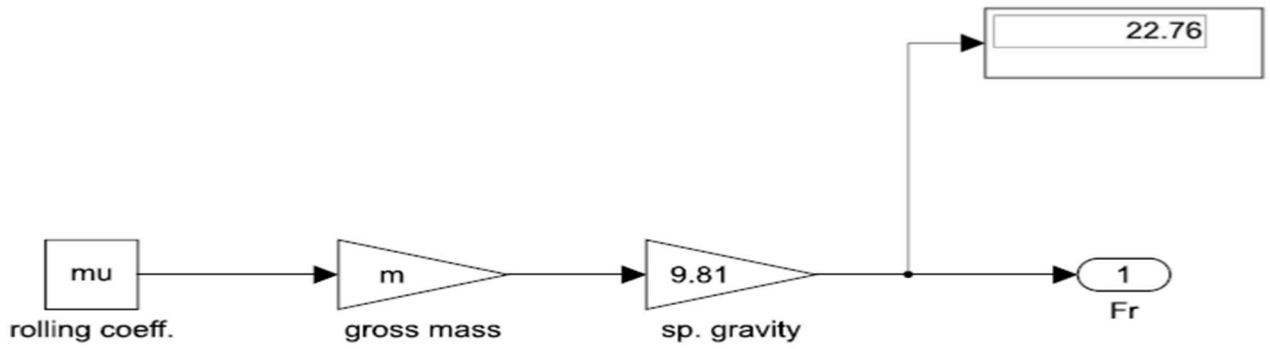

Rolling force

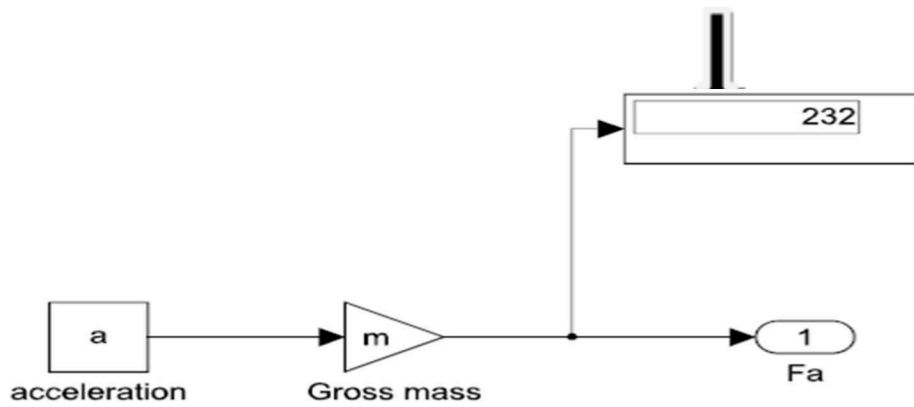

Acceleration force

- Now calculate the power subsystem

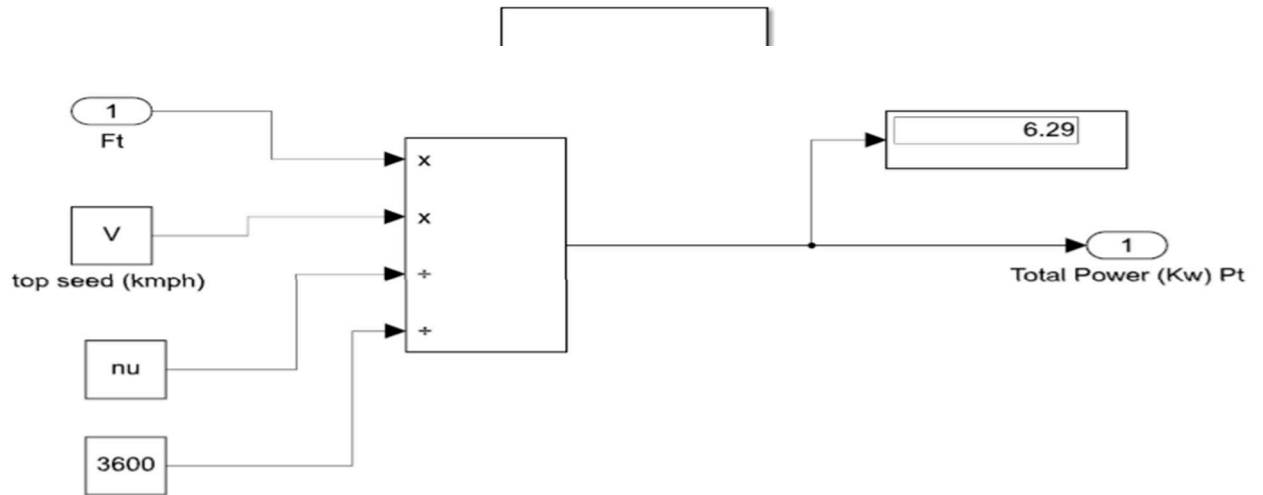

- Now calculate the energy subsystem.

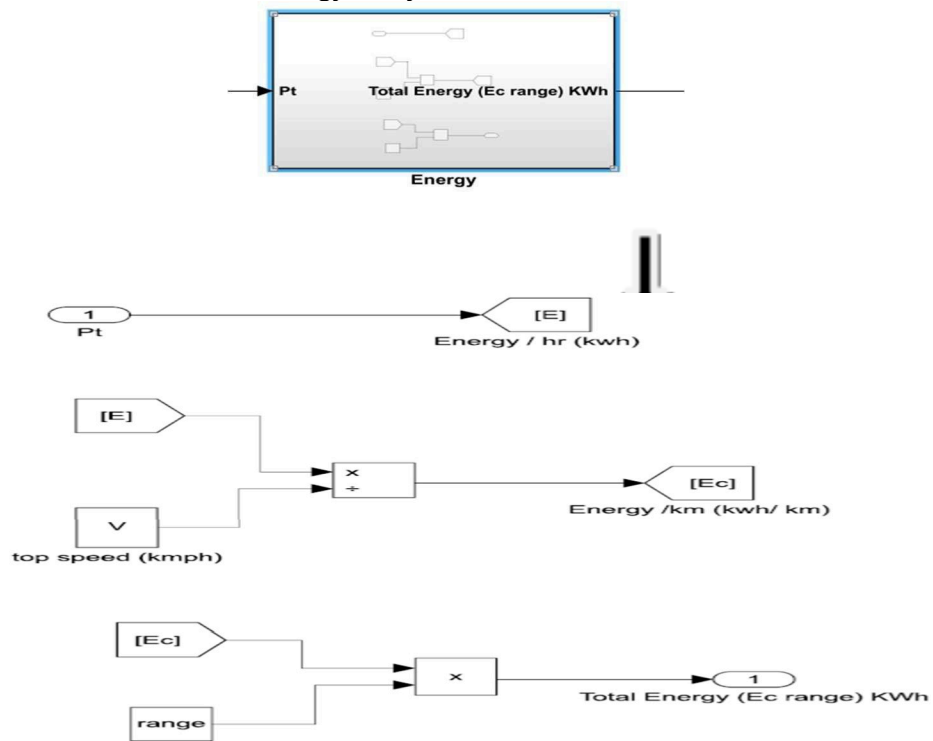

- Now calculate the motor output subsystem.

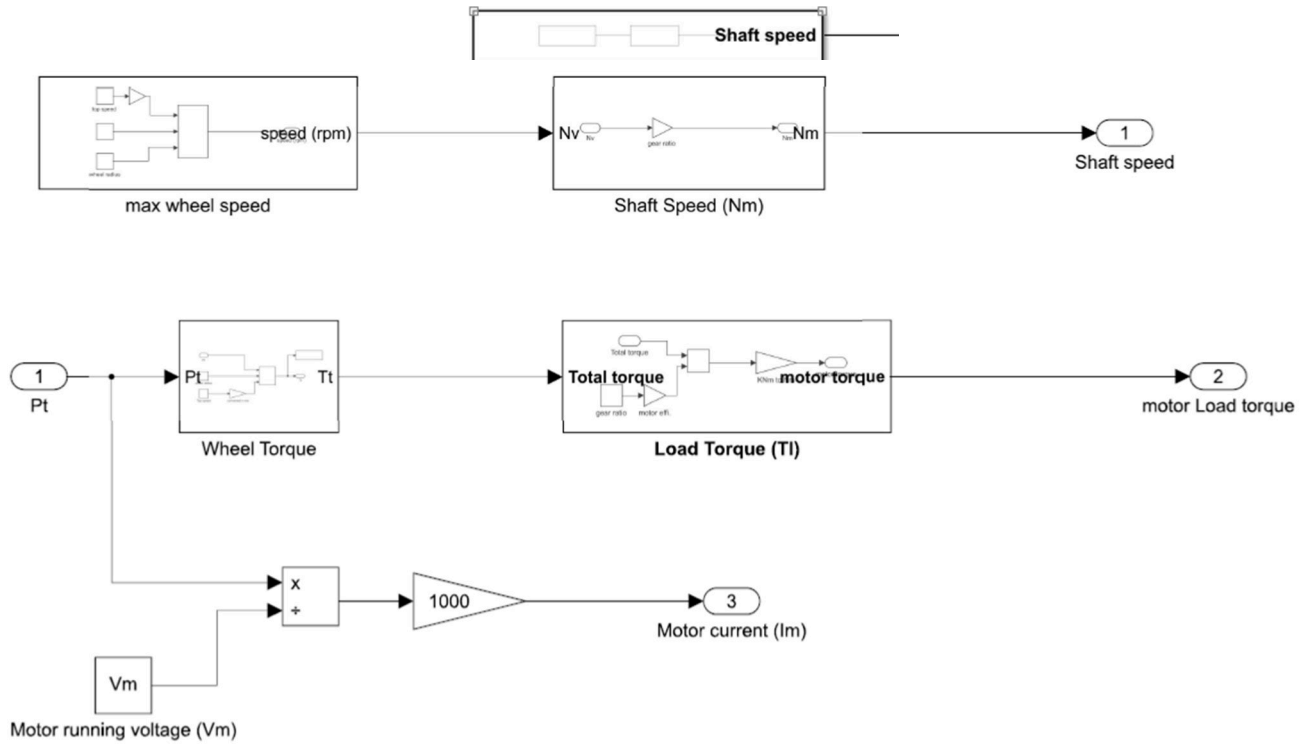

- Now calculating the battery pack subsystem.

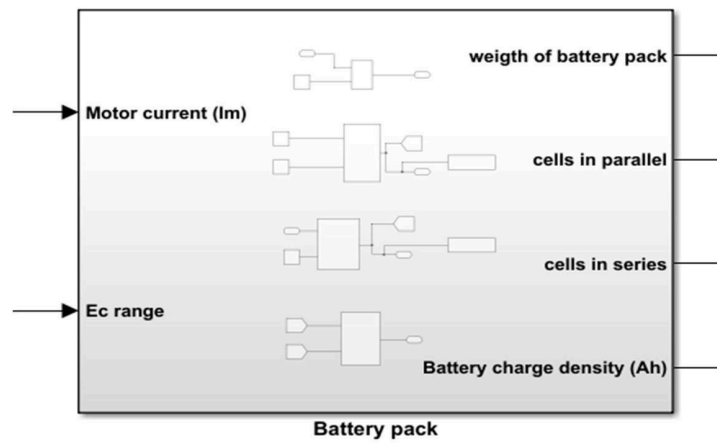

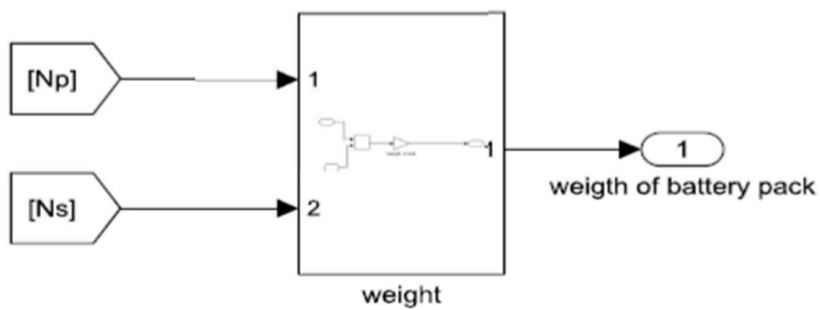
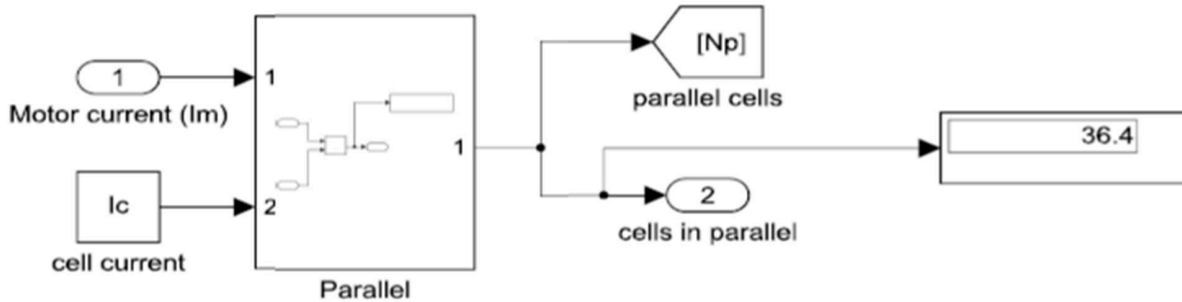
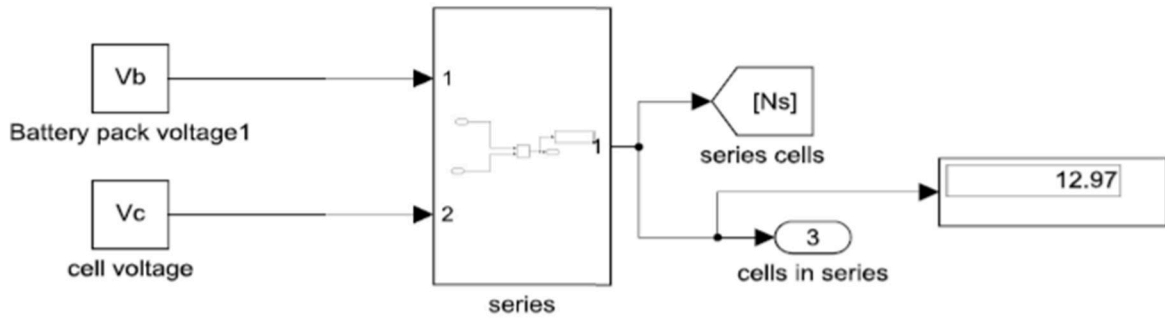
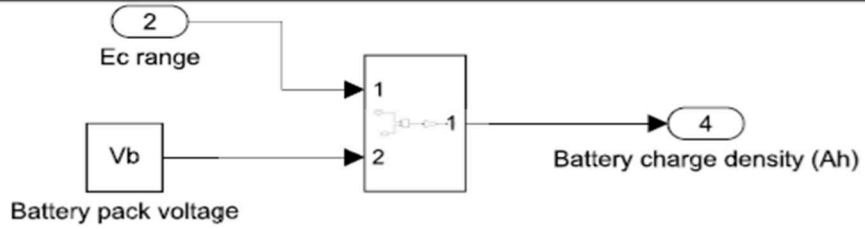

Chapter 4: Output Parameters

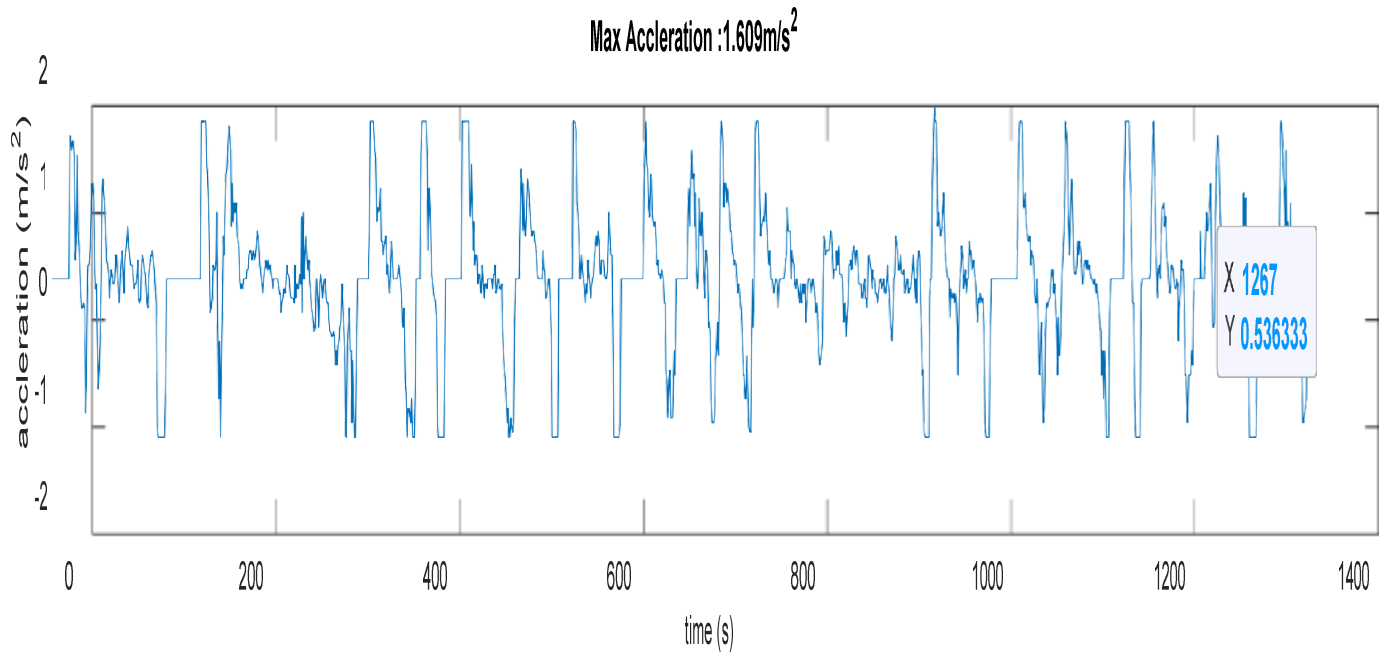
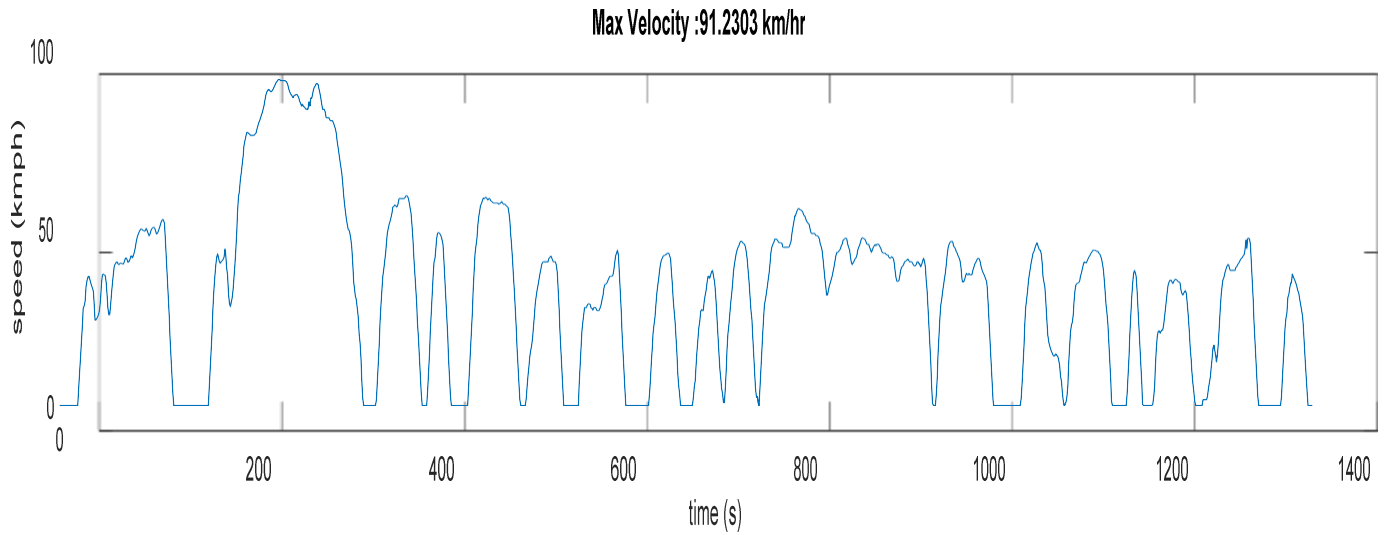

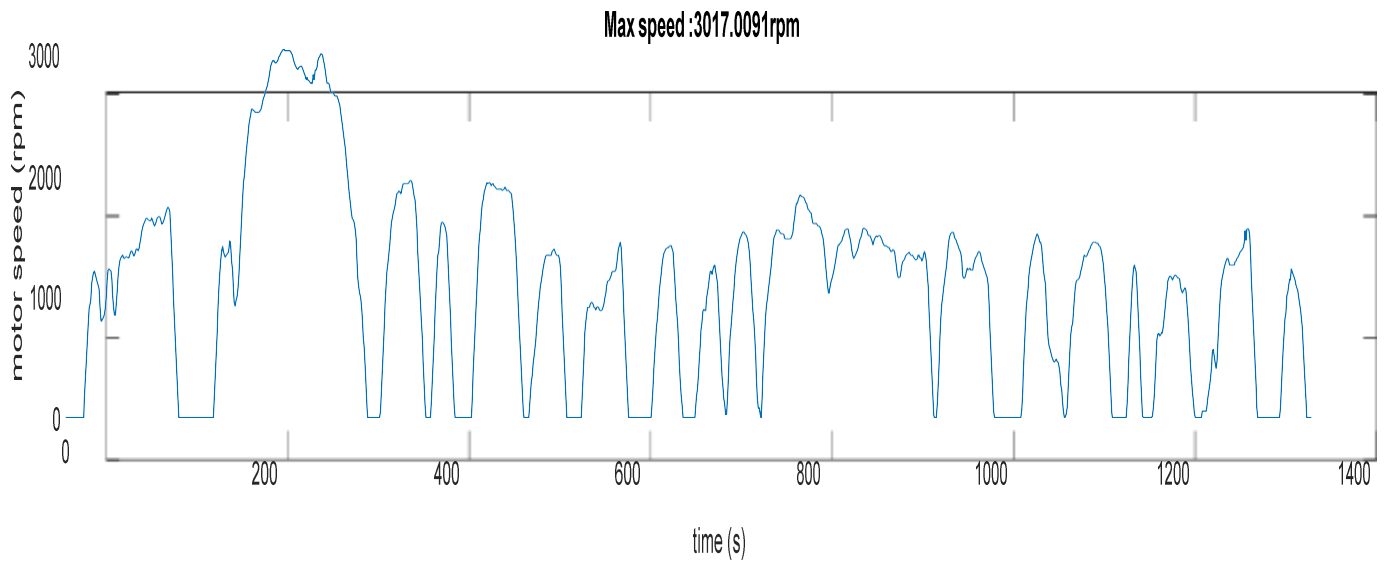
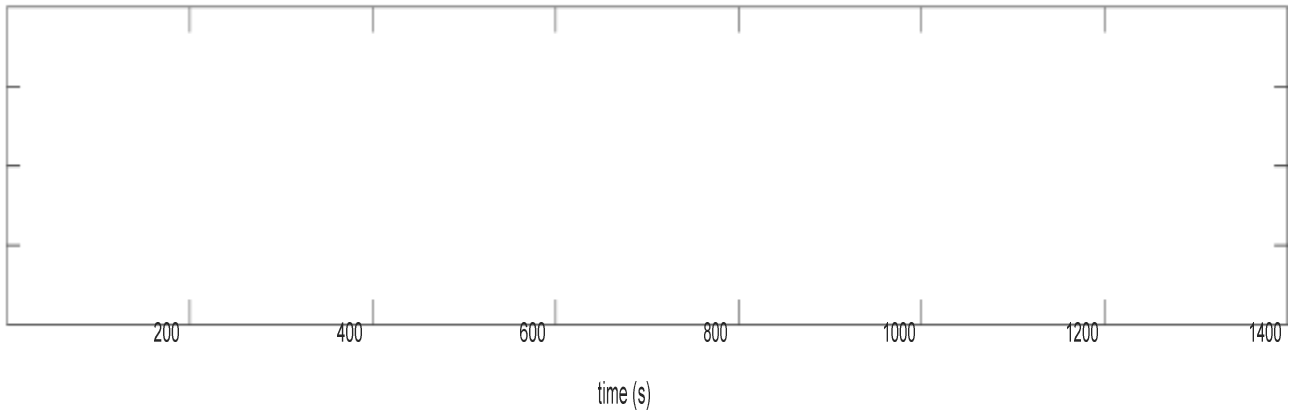
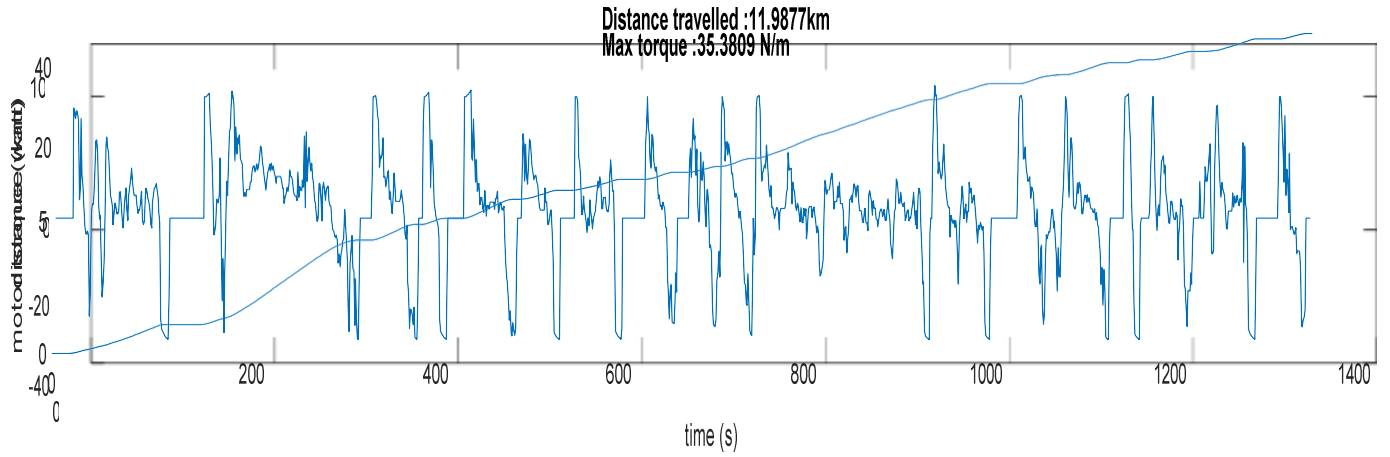

Max Power :6923.3048 watt

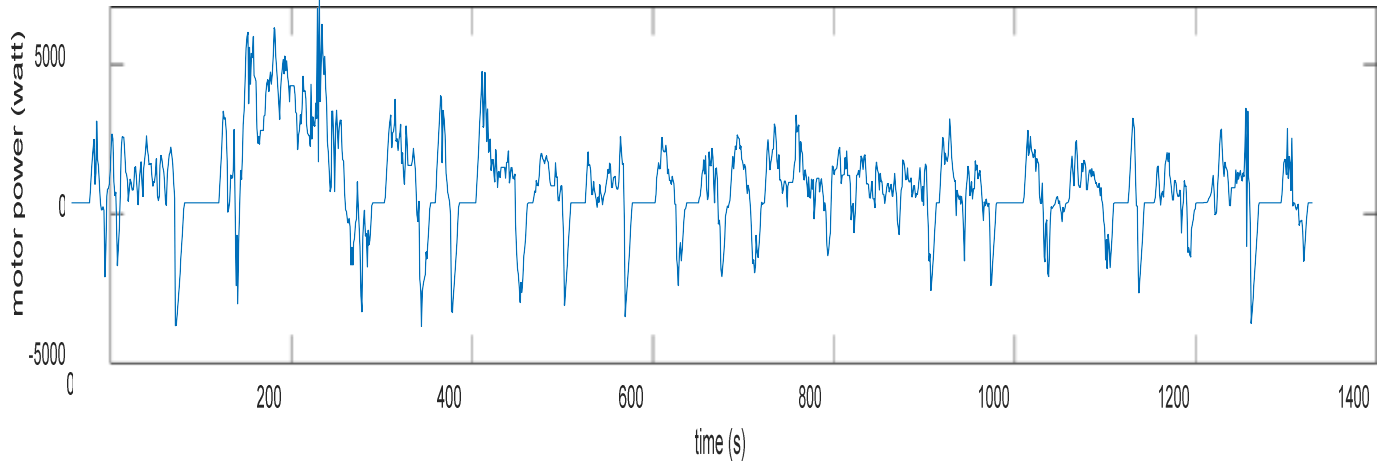

Energy consumed :0.26077 kWh

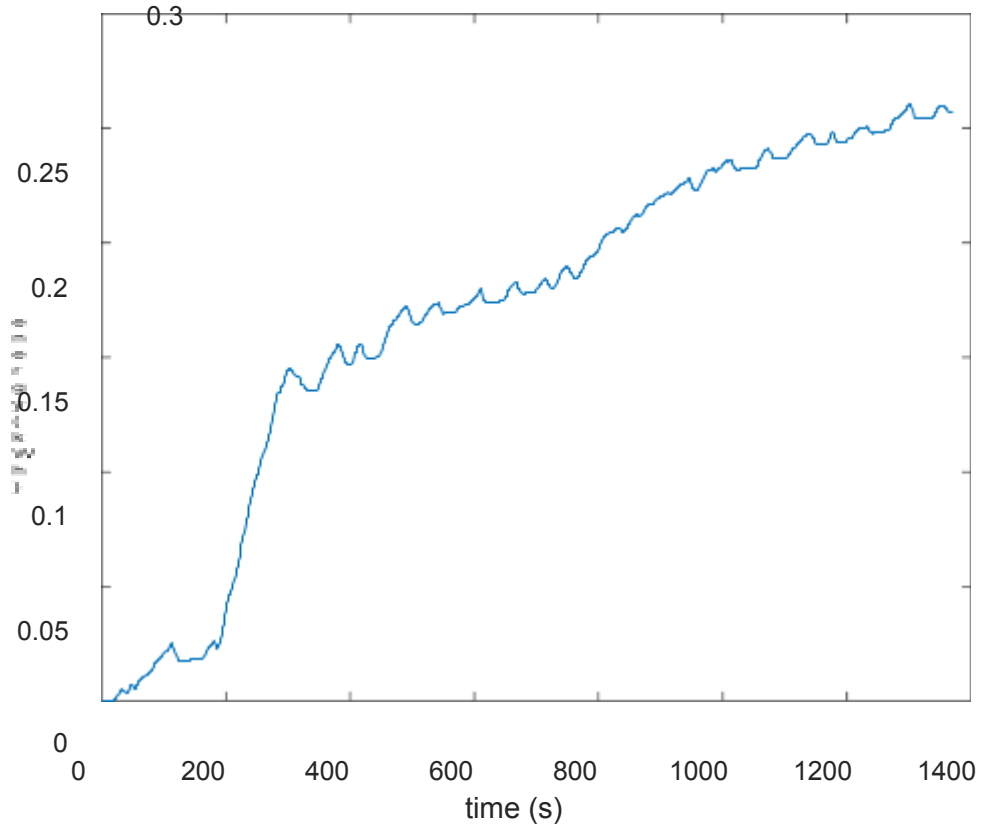

Chapter 5: Results & conclusions

The following outcomes came from above simulation results as follow:

- The max traction forced $F_T = 254.8 \text{ N}$
- Max power $P_T = 6.29 \text{ Kw}$
- Energy density $E_c = 0.08 \text{ kWh/km}$
- Total energy consumption $E_{C \text{ range}} = 12 \text{ kWh}$
- Motor speed $N_m = 2646 \text{ rpm}$
- Motor load torque $T_1 = 26 \text{ Nm}$
- Energy density of battery pack $E_d = 250 \text{ Ah}$
- Cells in series $N_s = 13$
- Cells in parallel $N_p = 37$
- Weight of battery pack $W_b = 22 \text{ kg}$