



Title: Times New Roman; Size-16; Line Spacing Exactly 20;

Paragraph Spacing: After Paragraph-24 pt.*^{1*}

First Author Name ^{12*}, Second Author Name², Third Author Name³,

¹Affiliation, E-mail address

²Affiliation, E-mail address

³Affiliation, E-mail address

ABSTRACT

This paper templet is copyright by Journal of Culture Accounting and Auditing (JCAA). The first page of the manuscript should include the title of the manuscript and complete contact information for each author with author name, affiliation, and email address. As noted, the corresponding author should be clearly noted in the case of multiple authors, and should be marked by *. In typing the abstract follow the aforementioned format without altering. Your abstract should not exceed from 250 words. The font size must be 11. Line spacing must be exactly 12 pt.

Type of Paper: Empirical/ Review

Keywords: Type keywords, separated by semicolons; a minimum of five keywords and maximum not more than ten.

1. Introduction

Preamble of the paper with the 12 font size and follow same for other sections. The paragraphs continue from here and are only separated by numbered headings, subheadings, images and formulae. The section headings are arranged by numbers, bold, font size is 12, line spacing must be exactly 12 pt. Spacing for headers must be 12pt., before and after.

General Rules: Margin must be Normal.

1

^{2*} Corresponding author:

E-mail: someone@text.com

Affiliation: Faculty, University

1.1 Heading-level 1

Title of sub-heading must be in Times New Roman, font size 12, *Italic*, Line spacing must be exactly 12 pt. Spacing must be 12 pt. before and after.

Type your sub-heading paragraphs here. Text must be in Times New Roman, font size must be 12. Line spacing must be exactly 12 pt.

Here follow the further instructions for authors.

2. Literature Review

Title of heading must be in Times New Roman, font size 12, **Bold**, Line spacing must be exactly 12 pt. Spacing must be 12 pt. before and after.

Type the paragraphs of the paper heading. Text must be in Times New Roman, font size must be 12. Line spacing must be exactly 12 pt.

2.1 Heading-level 1

Title of sub-heading must be in Times New Roman, font size 12, *Italic*, Line spacing must be exactly 12 pt. Spacing must be 12 pt. before and after.

Type your sub-heading paragraphs here. Text must be in Times New Roman, font size must be 12. Line spacing must be exactly 12 pt.

2.1.1 Heading-level 2

Title of sub-heading must be in Times New Roman, font size 12, Line spacing must be exactly 12 pt. Spacing must be 12 pt. before and after.

Type your sub-heading paragraphs here. Text must be in Times New Roman, font size must be 12. Line spacing must be 1.5 pt.

Bulleted lists must look like this:

- a. First point
- b. Second point
- c. And so on

Please do not alter the formatting and style layouts which have been set up in this template document. Do not number pages on the front, as page numbers will be added separately for the preprints. Leave a line clear between paragraphs.

3. Research Methodology

Type your paragraphs here. For all formatting structure refer to previous guidelines

3.1 Heading-level 1

Title of sub-heading must be in Times New Roman, font size 12, *Italic*, Line spacing must be exactly 12 pt. Spacing must be 12 pt. before and after.

Type your sub-heading paragraphs here. Text must be in Times New Roman, font size must be 12. Line spacing must be exactly 12 pt.

3.2 Tables

All tables should be numbered with Arabic numerals. Every table should have a caption. Headings should be placed above tables, font size 11, left justified. Tables must be embedded into the text and not supplied separately. Table format: font size must be 11, line spacing must be exactly 12 pt. Spacing must be 0 pt. Before; 6 pt. After and it must centered

Table 1. An example of a table.

An example of a column heading	Column A (<i>t</i>)	Column B (<i>t</i>)
And an entry	1	2
And another entry	3	4
And another entry	5	6

3.3 Illustrations

Illustrations must be numbered with Arabic numerals (e.g. Figure 1; Figure 2 ;...). The name of the figure must be written BELOW the figure. The font size must be 11, Spacing of figure name must be 6pt. before and 12pt. after, center justified.

Figures must be high quality which is a 300 DPI resolution to produce a high quality output. Authors are suggested to avoid any illustration which is unclear, diminishing and has fuzziness and low readability. The figure must not be distorted, out of margin and numbers can be seen clearly in the illustrations.

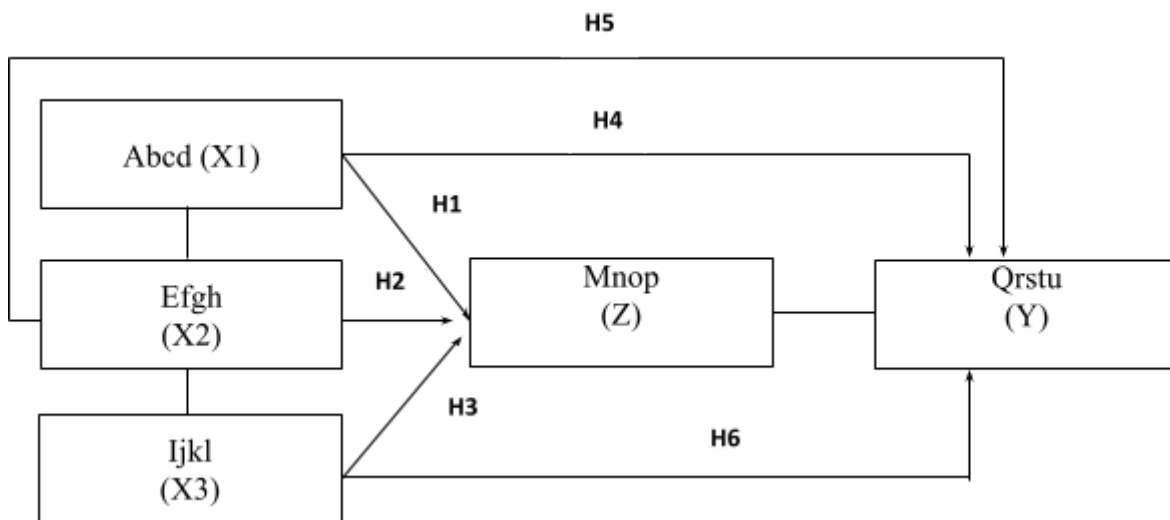

Figure 1. Name of the figure

4. Results

Type your paragraphs here. For all formatting structure refer to previous guidelines

4.1 Heading-level 1

Title of sub-heading must be in Times New Roman, font size 12, *Italic*, Line spacing must be exactly 12 pt. Spacing must be 12 pt. before and after.

Type your sub-heading paragraphs here. Text must be in Times New Roman, font size must be 12. Line spacing must be exactly 12 pt.

4.2 Equations

Equations and formulae should be typed in Mathtype, and numbered consecutively with Arabic numerals in parentheses on the right hand side of the page (if referred to explicitly in the text). They should also be separated from the surrounding text by one space.

$$AD = \frac{EP}{A_c (Z = \text{const.}) \cdot \left(U \cdot \left(\frac{T}{T_c} \right)^m + (1 - P) \right)} \quad (1)$$

5. Discussion

Type your paragraphs here. For all formatting structure refer to previous guidelines

5.1 Heading-level 1

Title of sub-heading must be in Times New Roman, font size 12, *Italic*, Line spacing must be 1.5 pt. Spacing must be 12 pt. before and after.

Type your sub-heading paragraphs here. Text must be in Times New Roman, font size must be 12. Line spacing must be 1.5 pt.

6. Conclusion

Type your paragraphs here. For all formatting structure refer to previous guidelines

Acknowledgements (If Any)

Type your acknowledgements here. Acknowledgements and Reference headings should be bold and left justified. First letter capitalized, but have no numbers. The font size 12. Line spacing must be 12pt.

References

As an APA (American Psychological Association) Referencing Style is most used one, we require the author to follow the style. Sort the reference list alphabetically. Use hanging indent (1 cm). The font size must be 11, line spacing must be 12pt.

Here are the samples in the format of APA Referencing Style (6th edition).

Journal article

Gibbs, M. (2005). The right to development and indigenous peoples: Lessons from New Zealand. *World Development*, 33 (8), 1365-1378.

A book

Surname1, A. A., & Surname2, B. B. (2013). This is a Sample Book Title Used for Illustration (3 ed.). Sample City: Sample Publisher.

Book chapter in an edited book

Helber, L. E. (1995). Redeveloping matures resorts for new markets. In M. V. Conlin & T. Baum (Eds.), *Island tourism: Management principles and practice* (pp.105-113). Chichester, England: John Wiley

Thesis

Dewstow, R. A. (2006). *Using the Internet to enhance teaching at the University of Waikato* (Master's thesis, University of Waikato, Hamilton, New Zealand).

Retrieved from <http://researchcommons.waikato.ac.nz/handle/10289/2241>

A conference

Surname1, A. A., & Surname2, B. B. (2013). *This is a Sample Article Title Used for Illustration*. Paper presented at the Sample Conference Name, Sample City.

Monographs:

Kalimapour, Y.R. (2004). *Images of the U.S. Around the World: A Multicultural Perspective*. Albany, NY: State University of New York Press.

Proceedings:

Amir Awang. (2006). Counseling, human resources development and counseling services. In Sulaiman M. Yassin, Yahya Mat Hassan, Kamariah Abu Bakar, Esah Munji and Sabariah Mohd. Rashid (Eds.), *Proceedings of Asia Pacific Conference on Human Development* (p. 243-246). Serdang: Universiti Putra Malaysia.

Footnotes

Footnotes should be avoided if possible. Necessary footnotes should be denoted in the text by consecutive superscript letters. The footnotes should be typed single spaced, and in smaller type size (8pt), at the foot of the page in which they are mentioned, and separated from the main text by a short line extending at the foot of the column.

Appendix A. An example appendix

Authors including an appendix section should do after the References section. Multiple appendices should all have headings in the style used above. They will automatically be ordered A, B, C etc.

Note:

1. If your paper is in Indonesian, then prepare the abstract in English. Conversely, if your paper is in English, prepare abstract in Indonesian.
2. Direct citation more than three lines should be typed at one spacing indented style.
3. The article should consist of no more than 7000 words in Times New Roman fonts (11-12 font size) include reference.
4. Top, bottom, left and right margin should be set to one inch.
5. All pages including tables, appendix and references should be labeled by page number.
6. Every table and picture should be numbered, titled and cited (if applicable).
7. Citations in the body of manuscript should confirm the following examples:
 - a. One citation resource with one author (Brownell, 1981).
 - b. One citation resource with two authors (Frucot and Shearon, 1991).
 - c. One citation resource with more than one author (Hotstede et al., 1990).

- d. Two citation resources with different authors (Dunk, 1990; Mia, 1988).
- e. Two citation resources with one author (Brownell, 1981, 1983).
- f. Two citation resources with one author published in the same year (Brownell, 1982a, 1982b).