

# Design and implementation of Mini Tesla Coil

Prepared by:

1. Muhammad Usama

2018-EE-09

2. Sajjad Hussain

2018-EE-37

3. Ghulam Yaseen

2018-EE-35

4. Muhammad Kashif

2018-EE-29

5. Abdul Wahab

2018-EE-1755

Course:

High Voltage Engineering

EEPS-802

Session: 2018-2022

BSc Electrical Engineering

Course Instructor:

Dr. Muhammad Kashif

Lab Instructor:

Engr. Usama Asad

**ELECTRICAL ENGINEERING BZU MULTAN**

[Date]

## **Design and implementation of Mini Tesla Coil**

### **Aims And Objective:**

The main objective of this project is design and implementation of Mini Tesla coil to generate high voltage so that spark can produce in the surrounding.

### **Introduction:**

The Tesla Coil is a machine for generating extreme high voltages. It's sort of like the Van De Graff generator, but much more powerful, when you fire it up, the shiny donut/sphere-shaped part on top is energized with about 500,000 volts of high-frequency current. The 'Tesla coil uses high-frequency transformer action together with resonant voltage amplification to generate potentials in the range of tens to hundreds, or even thousands of kilovolts.

About 100 years ago Nikola Tesla invented his "Tesla Coil". Tesla invented his coil with the intention of transmitting electricity through the air. He conducted much research in this area. He purposed using a few coils spread across the globe to transmit electrical energy through the earth. Wherever power was needed one would need only a receiving coil to convert the pow into a useful form. Tesla coil circuits were used commercially in spark gap radio transmitters for wireless telegraphy until the 1920s, and in electrotherapy and pseudo medical devices such as violet ray. Today, their main use is entertainment and educational displays.

It is Used to generate or produce high voltage, low current & high frequency AC electricity. High frequency resonant transformer is used tesla coil. The commonly used high frequency resonant transformer is the Tesla coil. Tesla coil is a doubly tuned resonant circuit. The primary voltage rating is 10 kV and the secondary may be rated to as high as 500 to 1000 kV. Output frequency range: 50kHz to 1 MHz. Damped oscillations can be obtained by using Tesla Coil.

### **Solid State Tesla Coil:**

A solid-state Tesla coil is one of the kinds of Tesla coils available. It has several advantages over the more common spark gap tesla coil. They are less loud than conventional Tesla coils, yet they can still achieve a respectable output. They can also be made to play music through its spark, which is a cool effect. Examples of this trick can be seen by searching for musical tesla coil or singing tesla coil. They are also more friendly to nearby electronic apparatus, although caution should still be applied.

### **Equipment Lists:**

Here are the following components used in project

1. PVC pipe having dimensions as follows; Length of pipe is 15cm and diameter is 2.5cm
2. Transistor-TIP41C
3. Capacitor-1 $\mu$ F/105 or 2.2 $\mu$ F/225 (100 plus volt)

4. Copper wire-0.3785mm/28SWG (700 plus turns)
5. Resistor-10k
6. Jumper/Connecting wires
7. Breadboard
8. Solid Basement of Project
9. Aluminum Heat-sink
10. Heat-sink paste
11. Transparent tape
12. DC generator module for DC supply

**Schematic Diagram:**

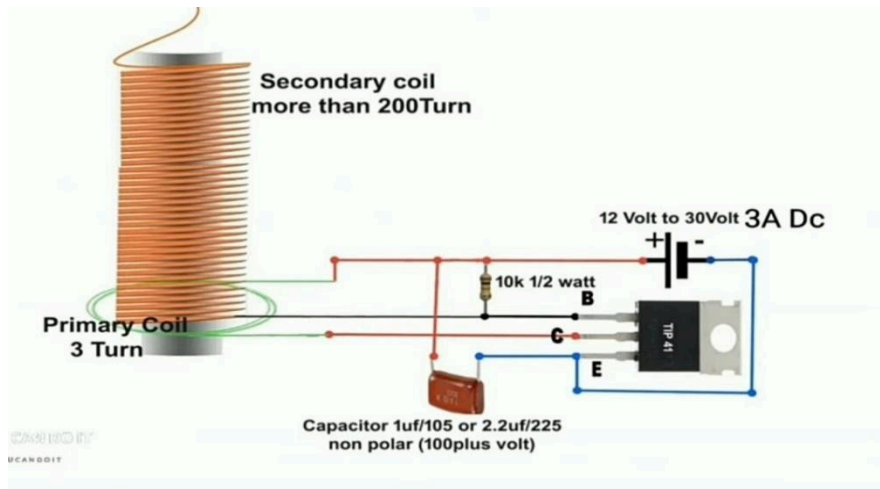

**Fig 1: Schematic Diagram of Tesla Coil**

**Circuit Diagram:**

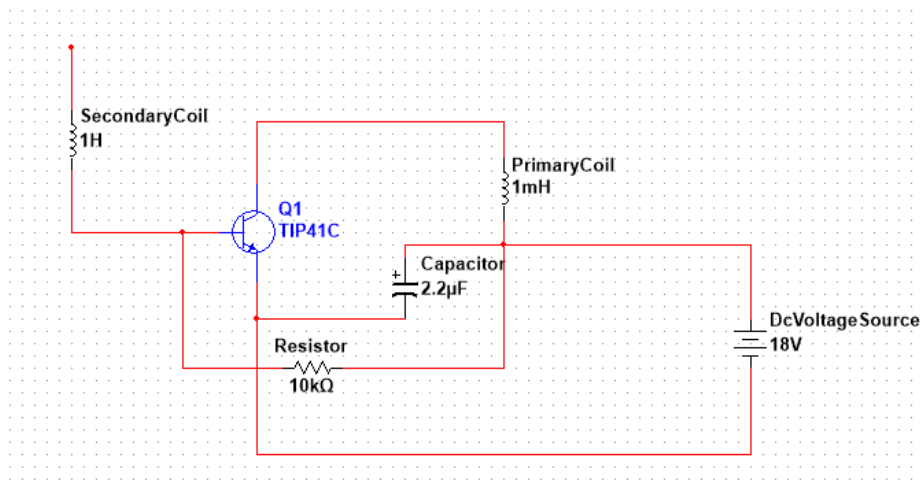

**Fig 2: Circuit Diagram of Tesla Coil**

## **Explanation:**

### **Primary Circuit:**

The circuit diagram of Mini Tesla Coil Project given below is very simple. So let us understand how it works and learn how to build it. The main component in this circuit is the secondary coil (golden color), which is made by winding a magnetic wire (enameled) around a cylindrical object (any nonconductive object will work). A high current high frequency transistor like **Tip41C** is used to supply current through the primary coil (violet color). The whole set up is powered by a 18V Voltage Source as shown above.

The positive end of the battery reaches the collector of Transistor through the primary coil, and the emitter is grounded. This means that whenever the transistor conducts, current is flown through the primary coil. The LED diode and one end of the secondary coil is also connected to base of transistor to make the circuit oscillate, this way the transistor will send a oscillating current into primary coil. If you want get more technical and learn how the current oscillates you can Google for “Slayer Exciter Circuit

So, with this arrangement we have a primary coil which will have an oscillating current, and hence will produce a carrying magnetic flux around it. Now, this coil is wound around the secondary coil and hence a according to law of electromagnetic induction a voltage will be induced in the secondary coil. . Since the number of turns in the secondary coil is very large than primary coil, this voltage will be a very high voltage and hence this coil will have a very strong electric flux around it.

### **Secondary Coil:**

One very important step in this project is winding the secondary coil. It is a time-consuming process and hence do not rush yourself in this part. First of all, you will need a magnetic coil, which is also called as enameled coil wire. These wires can be found inside relays coils, transformers and even motors. You can either reuse one or buy yourself a new one. The thinner the wire is the better the results will be. Once you are ready with the magnetic wire, you will need a cylindrical object. The only rule while selecting this object is that it should not be conductive, you can select PVC pipes, cardboard roll or even stack 4-5 A4 sheets together and roll them up. The diameter of the cylinder can be anywhere between 5cm to 10cm, and the length should be at least 10cm. The longer the object is more number of turns it can fit in. After getting your coil and cylindrical object, it is time to start the winding process, just wind few turn and use a tape to secure the winding initially and then proceed with the complete winding. Make sure you follow the below tips while winding

1. Wind the coils as close as possible
2. Do not overlap one coil turn over another

3. Try to get a minimum of 150 turns, a value of 300 turns will be typically good.

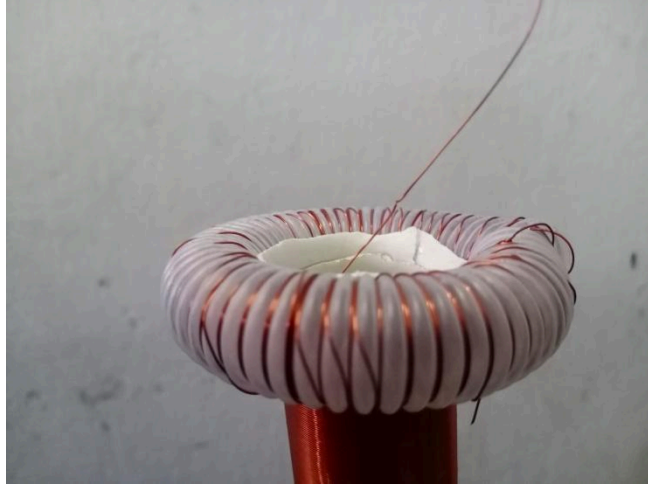

**Fig 3: Secondary Coil**

### **Toroid Circuit:**

Most Tesla coil designs have a smooth spherical or toroidal shaped metal electrode on the high voltage terminal. The electrode serves as one plate of a capacitor, with the Earth as the other plate, forming the tuned circuit with the secondary winding. Although the "toroid" increases the secondary capacitance, which tends to reduce the peak voltage, its main effect is that its large diameter curved surface reduces the potential gradient (electric field) at the high voltage terminal; it functions similarly to a corona ring, increasing the voltage threshold at which air discharges such as corona and brush discharges occur. Suppressing premature air breakdown and energy loss allows the voltage to build to higher values on the peaks of the waveform, creating longer, more spectacular streamers when air discharges finally occur.

If the top electrode is large and smooth enough, the electric field at its surface may never get high enough even at the peak voltage to cause air breakdown, and air discharges will not occur. Some entertainment coils have a sharp "spark point" projecting from the torus to start discharges.



**Fig 4: Secondary Coil**

**Estimated Cost:**

The estimated cost of project including all components and other expenses is round about one thousand rupees only. Here below is the following details

<b>Equipment</b>	<b>Price(Rs.)</b>
PVC Pipe	30
Transistors	$80 \times 2 = 160$
Capacitors	$40 \times 2 = 80$
Copper Wire	300
Resistors	$10 \times 2 = 20$
Jumper/Connecting Wires	50
Breadboard	150
Solid Basement	50
Aluminum Heat-sink	40
Heat-sink Paste	20
Transparent Tape	30
Other Expenses	70
<b>Grand Total</b>	<b>1000/=</b>

**Project Plan:**

<b>Group Members Name</b>	<b>Respective Roles/Tasks</b>
Muhammad Usama	<ul style="list-style-type: none"><li>✓ Read and Research about project</li><li>✓ Visited Market and purchased Equipment's</li><li>✓ Worked on hardware parts</li><li>✓ Great Contribution</li></ul>
Muhammad Kashif	<ul style="list-style-type: none"><li>✓ Read about project</li><li>✓ Visited Market and purchased Equipment's</li><li>✓ Worked on hardware parts</li><li>✓ Good job</li></ul>
Ghulam Yaseen	<ul style="list-style-type: none"><li>✓ Read about project</li><li>✓ Visited Market and purchased Equipment's</li><li>✓ Worked on hardware parts</li><li>✓ Did Software work i.e Lab Report</li></ul>

	<ul style="list-style-type: none"><li>✓ Amazing Job</li></ul>
Sajjad Hussain	<ul style="list-style-type: none"><li>✓ Read about project</li><li>✓ Visited Market and purchased Equipment's</li><li>✓ Worked on hardware parts</li><li>✓ Did Software work i.e presentation</li><li>✓ Wonderful Work</li></ul>
Abdul Wahab	<ul style="list-style-type: none"><li>✓ Read and Research about project</li><li>✓ Worked on hardware parts</li><li>✓ Did Software work i.e Lab Report</li><li>✓ Nice Job</li></ul>

**Weekly Plan:**

**Fourth Week**



Components

**Sixth Week**

**Group Leader**  
**Muhammad**  
**Usama**  
**Roll No 2018-EE-09**

**Project**  
**Management**

**M Usama**  
**2018-EE-09**

**Sajjad Hussain**  
**2018-EE-37**

**M. Kashif**  
**2018-EE-29**

**Abdul Wahab**

## **Fifth Week**

### **Second and Third Week**



### **First Week**



### **Seventh Week**

#### **Utilization/Application of Project:**

Tesla used these circuits to conduct innovative experiments in electrical lighting, phosphorescence, X-ray generation, high frequency alternating current phenomena, electrotherapy, and the transmission of electrical energy without wires. Tesla coil circuits were used commercially in spark gap radio transmitters for wireless telegraphy until the 1920s,[7][8] and in medical equipment such as electrotherapy and violet ray devices. Today, their main usage is for entertainment and educational displays, although small coils are still used as leak detectors for high vacuum systems.[1][9]

Tesla coils or resonant transformers of high frequency and high potential have been used in many commercial applications; the only variation being the high voltage is used to produce an effect other than a spark. Although not all commercial applications for Tesla coils are still in use some historical and modern-day applications including:

- Spark gap radio transmitters
- Induction and dielectric heating (vacuum tube & park gap types)
- Induction coils (differ only in the transformer core material being used)
- Medical X-ray devices (typically driven by an induction coil)
- Quack medical devices (violet-ray) Ozone generators
- Particle accelerators

#### **Vacuum system leak detectors:**

Scientists working with high vacuum systems test for the presence of tiny pin holes in the apparatus (especially a newly blown piece of glassware) using high-voltage discharges produced by a small handheld Tesla coil. When the system is evacuated the high voltage electrode of the coil is played over the outside of the apparatus. At low pressures, air is more easily ionized and thus conducts electricity better than atmospheric pressure air. Therefore, the discharge travels through any pin hole immediately below it, producing a corona discharge inside the evacuated space which illuminates the hole,

indicating points that need to be annealed or re-blown before they can be used in an experiment.

### Result and Discussion:

Tesla coil, we made works on DC supply. We noted that as DC voltage increased from 0V up-to 15V, spark is generated. The intensity level of spark becomes maximum as voltage level is increased above 18V. As spark generated, we noticed that Current during spark generation is below 1A. Also, we noticed that a healthy spark is produced as current increased to 3A and voltage increased up-to 30V. We also saw that as current increased from 3A, Capacitor burnt out. We did this project two times and noticed the same result in second time as we got during first attempt.

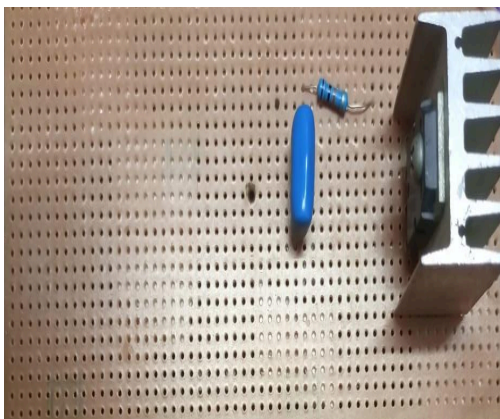

Fig 4: Primary Circuit

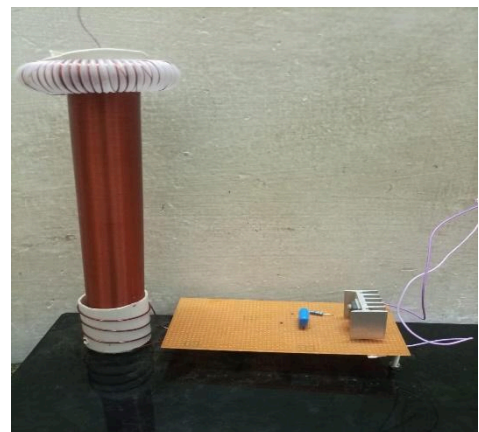

Fig 5: Complete Circuit



**Fig 6:Spark Output of Tesla Coil**

**Conclusion:**

In this project, we learnt about tesla coil. We learnt how to design the tesla coil. We worked on different Components and saw their working manually and practically. We read different articles and research papers related to tesla coil. We enjoyed the group work. We finally got succeeded to design tesla coil.

**References:**

1. Plesch P. H. (2005). High Vacuum Techniques for Chemical Syntheses and Measurements. Cambridge University Press. p. 21. ISBN 978-0-521-67547-5.
2. Gottlieb, Irving (1998). Practical Transformer Handbook. Newnes. p. 551. ISBN 978-0080514567.
3. Goldsmith, Paul (2010). Serious Fun: The Life and Times of Alan Gibbs. Penguin Random House. p. 219. ISBN 9781869799304.
4. "Lightning On Demand, Brisbane CA". The Electrum Project. Archived from the original on 2011-07-27.
5. "Rice University scientists take key step to create a 'force field'". 14 April 2016.
6. "Teslaphoresis lends the ability to massively scale up force fields to move matter remotely - Innovation Toronto". 18 April 2016.
7. Uth Robert (December 12, 2000). "Tesla coil". Tesla: Master of Lightning. PBS.org. Retrieved 2008-05-20.
8. Tilbury, Mitch (2007). The Ultimate Tesla Coil Design and Construction Guide. New York: McGraw-Hill Professional. p. 1. ISBN 978-0-07-149737-4.
9. Cvetić, Jovan M. (October 2016). "Tesla's High Voltage and High Frequency Generators with Oscillatory Circuits". Serbian Journal of Electrical Engineering. 13 (3): 301–333. doi:10.2298/SJEE1603301C. S2CID 55561957.