

Title Maximum 3 Lines with Maximum Word Count 20

First Author^{1}, Second Author²*

¹*Affiliation, e-mail*

²*Affiliation, e-mail*

Abstract: This abstract is in English with a number of words between 150-250 words, by including the research objectives, methods, and findings. This abstract is in English with a word count between 150-200 words, by including the research objectives, methods, and findings. This abstract is in English with a word count between 150-200 words, by including the research objectives, methods, and findings. This abstract is in English with a word count between 150-200 words, by including the research objectives, methods, and findings. This abstract is in English with a word count between 150-200 words, by including the research objectives, methods, and findings. This abstract is in English with a word count between 150-200 words, by including the research objectives, methods, and findings. This abstract is in English with a word count between 150-200 words, by including the research objectives, methods, and findings. This abstract is in English with a word count between 150-200 words, by including the research objectives, methods, and findings. This abstract is in English with a word count between 150-200 words, by including the research objectives, methods, and findings. This abstract is in English with a word count between 150-200 words, by including the research objectives, methods, and findings. This abstract is in English with a word count between 150-200 words, by including the research objectives, methods, and findings. This abstract is in English with a word count between 150-200 words, by including the research objectives, methods, and findings. This abstract is in English with a word count between 150-200 words, by including the research objectives, methods, and findings. This abstract is in English with a word count between 150-200 words, by including the research objectives, methods, and findings. This abstract is in English with a word count between 150-200 words, by including the research objectives, methods, and findings.

Keywords: keywords1, keywords2, keywords3, keywords4

JEL Classification:

* **Corresponding author's e-mail:** email.correspondence@email.you

ISSN: 2686-4789 (Print); ISSN: 2686-0473 (Online)

<http://icehos.nusaputra.ac.id>

INTRODUCTION

In the introduction, include the background to your research, the purpose of your research, and / or anything else you think is important to write about as part of the

introduction. Follow the rules of writing good and correct English. Such as minimizing typos and using the number of sentences in an appropriate paragraph.

In the introduction, include the background to your research, the purpose of your research, and / or anything else you think is important to write about as part of the introduction. Follow the rules of writing good and correct English. Such as minimizing typos and using the number of sentences in an appropriate paragraph.

In the introduction, include the background to your research, the purpose of your research, and / or anything else you think is important to write about as part of the introduction. Follow the rules of writing good and correct English. Such as minimizing typos and using the number of sentences in an appropriate paragraph.

In the introduction, include the background to your research, the purpose of your research, and / or anything else you think is important to write about as part of the introduction. Follow the rules of writing good and correct English. Such as minimizing typos and using the number of sentences in an appropriate paragraph.

In the introduction, include the background to your research, the purpose of your research, and / or anything else you think is important to write about as part of the introduction. Follow the rules of writing good and correct English. Such as minimizing typos and using the number of sentences in an appropriate paragraph.

LITERATURE REVIEW

First Literature

Provide a concise and clear literature review in your article.

Second Literature

Provide a concise and clear literature review in your article.

Third Literature

Provide a concise and clear literature review in your article.

Hyphothesis

Write down if any, along with pictures.

METHODOLOGY

Research Strategy

Write it here, like this.

Measurement

Write it here, like this.

Population and Sample

Write it here, like this.

Sampling Method

Write it here, like this.

Research Object

Write it here, like this.

Data Collection

Write it here, like this.

Research Instrument

Write it here, like this.

Data Analysis

Write it here, like this.

DISCUSSION

Respondents Profile

Write it here, like this.

Table 1. Example of table writing

Variable	Min	Max	Skew	C.R.	Kurtosis	C.R.
GTE1	1	5	-1,504	-9,11	2,04	6,178
GTE2	1	5	-0,799	-4,835	0,171	0,517

GTE3	1	5	-0,435	-2,634	-0,462	-1,398
GTE4	1	5	-1,001	-6,061	1,877	5,682
GTE5	1	5	-0,968	-5,864	2,175	6,587
KW1	2	5	-0,192	-1,164	-0,032	-0,098
KW2	1	5	-0,85	-5,146	2,945	8,917
KW3	2	5	-0,64	-3,873	0,132	0,4
KW4	3	5	-0,341	-2,062	-0,724	-2,192
KW5	2	5	-0,511	-3,092	0,333	1,008
KW6	2	5	-0,252	-1,524	-0,336	-1,017
MD1	2	5	-1,287	-7,793	1,49	4,511
MD2	3	5	-0,81	-4,906	-0,431	-1,306

Lanjutan Tabel 2.

MD3	3	5	-0,685	-4,148	-0,507	-1,534
KP1	2	5	-0,282	-1,708	-0,562	-1,703
KP2	2	5	-0,276	-1,669	-0,374	-1,132
KP3	1	5	-0,508	-3,077	-0,173	-0,524
KP4	1	5	-0,222	-1,347	-0,403	-1,221
SKD1	1	5	-0,008	-0,049	-0,24	-0,727
SKD2	2	5	-0,191	-1,158	-0,811	-2,456
SKD3	2	5	-0,07	-0,426	-0,714	-2,161
Multivariate					94,273	22,495

Source: Own (2020)

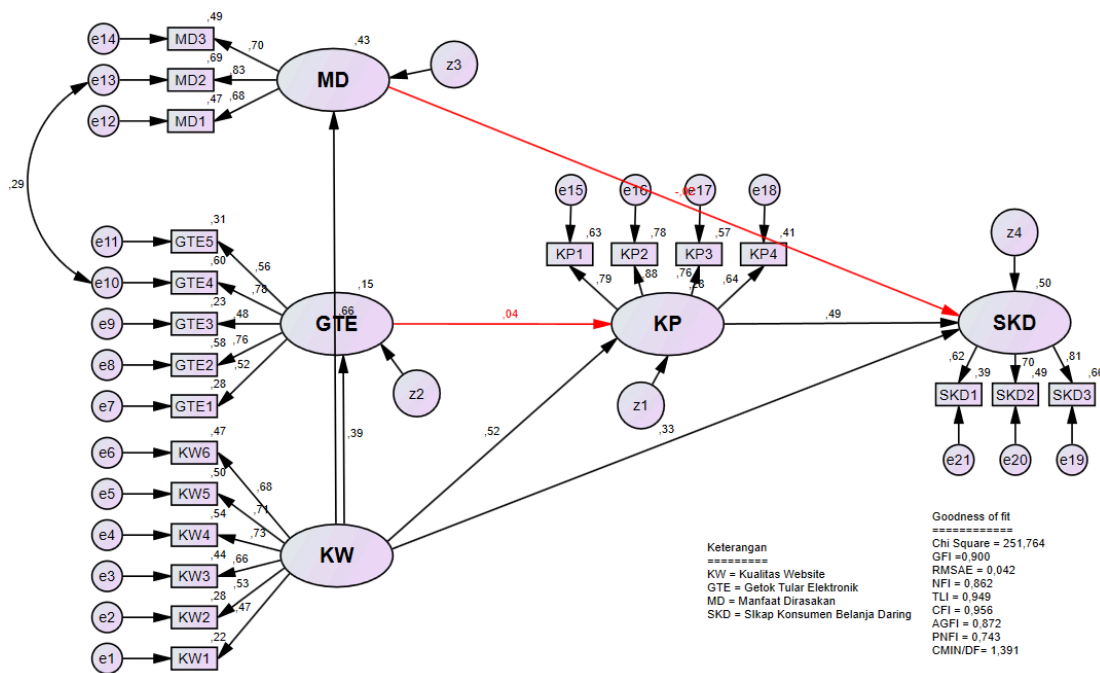

Figure 2. Example of figure

Discuss any tables and figures that exist.

CONCLUSION

Make conclusions according to your research objectives.

REFERENCE

- Alba, J. (1997). Interactive home shopping, retailer, and manufacturer incentives to participate in electronic marketplace, *Journal of Marketing*, Vol. 61, No 7, pp. 38-53.
- Al-Debei, M.M; Akroush, M.N; and Ashouri, M.I. (2015). Consumer attitudes towards online shopping: The effects of trust, perceived benefits, and perceived website quality, *Internet Research*, Vol. 25, No. 5, pp. 707-733.
- Al-Lozi, E. (2011). *Explaining user intention to continue participating in website 2.0 communities: the case of facebook in the Hashmite kingdom of Jordan*. London: Brunel University.
- Becherer, R. C and Halstead, D. (2004). Characteristics and Internet Marketing Strategies of Online Auction Sellers: Int. J, *Internet Marketing and Advertising*, Vol. 1, No. 1, pp 24-37.
- Chang, H. H. and Wang, H. S. (2011). The moderating effect of customer perceived value on online shopping behavior, *Online Information Review*, Vol. 35, No. 3, pp. 333-359.
- Cheung, C.M. and Thadani, D.R. (2012). The impact of electronic word-of-mouth communication: a literature analysis and integrative model, *Decision Support System*, Vol 54, No.1, pp. 461-470.
- Cooper, D.R. and Schindler, P.S. (2014). *Business Research Methods, 12th ed.* New York: McGraw Hill.
- Cox, J. and Dale, B. (2002). Key quality factor in website design and use: An Examination, *International Journal quality and reliability management international*, Vol. 19, No.7, pp. 862-888.
- Dhelafruz, N; Laly, P; and Ali, K. (2009). Developing an instrument for measurement of attitude toward online shopping, *European Journal of Social Science*, Vol. 7, No. 3, pp. 166-177.
- Forstythe, S; Liu, C; and Shannon, D. (2006). Development of a Scale to Measure the Perceived Benefits and Risk of Online Shopping. *Journal of Interactive Marketing*, Vol. 20, No, 2, pp. 55-75.
- Ganeshan, S. (1994). Determinants of long-terms orientation in buyer-seller relationship, *The Journal of Marketing*, Vol. 58, No. 2, pp. 1-19.
- Gefen, D; Karahanna, E; and Straub, D.W. (2003). Trust and TAM in online shopping: An Integrated Model, *MIS Quarterly*, Vol. 27, No. 1, pp. 51-90.
- Ghozali, I. and Fuad. (2005). *Structural Equation Modelling*: Semarang: Badan Penerbit Universitas Diponegoro.
- Ghozali, I. (2006). *Aplikasi Analisis Multivariate dengan Program SPSS (Edisi Ke 4)*. Semarang: Badan Penerbit Universitas Diponegoro.
- Hair, J.F; Black, W; Babin, B; Anderson, R; and Tatham, R. (2010). *Multivariate data analysis, 7th ed.* Upper Saddle River, NJ: Pearson Prentice Hall.
- Hennig, T.T; Gwinner, K.P; Walsh G; and Gremler, D.D. (2004). Electronic word-of-mouth via consumer-opinion platforms: what motivates consumer to articulate themselves on the internet, *Journal of interactive marketing*, Vol. 18, No.1, pp.38-52.
- Hsiao, K; Lin, J; Wang, X; Lu, H; and Yu, H. (2010). Antecedents and consequence of trust in online product recommendations: an empirical study in social shopping. *Online Information Review*. Vol. 34, No. 6, pp. 935-953.
- Hsu, C. L. and Lu, H. P. (2004). Why do people play on-line games? An extended TAM with social influences and flow experience, *Information and Management*, Vol. 41, pp. 853-868.
- Jarvenpaa, S. and Tractinsky, N. (1999). Consumer trust in an internet store: a cross-cultural validation. *Journal of Computer-mediated Communication*. Vol 5, No. 2, pp. 1-33.
- Kim, D.J; Ferrin, D.L; and Rao, H.R. (2008). A trust based consumer decision making model in electronic commerce: The role of trust perceived risk and their antecedent, *Decision Support Systems*, Vol. 44, No. 2, pp. 544-564.
- Kim, H. and Niehm, L. S. (2009). The impact of website quality on information quality, value, and loyalty intentions in apparel retailing. *Journal of Interactive Marketing*, Vol. 23, No 3, pp. 207-284.
- Kotler, P. and Keller, K.L. (2015). *Marketing Management. 15th ed.* Upper Saddle River. New Jersey: Pearson Prentice Hall.
- Litvin; S; Goldsmith, R; and Pan, B. (2008). Electronic word of mouth in hospitality and tourism management, *Journal of Tourism Management*, Vol. 29, pp. 458-468.
- McKnight, D.H. dan Chervany, N.L. (2002). What Trust Means In E-Commerce Customer Relationships: An Interdisciplinary Conceptual Typology. *International Journal of Electronic Commerce*, Vol. 6, No. 2, pp. 35-59.
- McKnight, D.H; Choudhury, V; and Kacmar, C. (2002). The impact of initial consumer trust on intentions to transact with a website: a trust building model, *Journal of Strategic Information System*, pp. 297-323.

- Mukherjee, A. and Nath, P. (2007). Role of electronic trust in online retailing: A re-examination of the commitment-trust theory. *European Journal of Marketing*, Vol. 41, No. 9/10, pp. 1173-1202.
- O’Cass, A. and Carlson, J. (2012). An e-retailing assessment of perceived website-service innovativeness: implication for *website* quality evaluation, trust, loyalty and word of mouth, *Australasian Marketing Journal (AMI)*, Vol. 20, No. 1, pp. 28-36.
- Pavlou, P. A. (2003). Consumer Acceptance of Electronic Commerce: Integrating Trust and Risk with The Technology Acceptance Model. *International Journal of Electronic Commerce*. Vol. 7, No. 3, pp 101-134.
- Peterson, R.A. (1994). A Meta-Analysis of Cronbach's Coefficient Alpha. *Journal of Consumer Research*, Vol. 21, No. 2, pp. 381-391.
- Rahmayani, D.P. (2016). Analisis Efek Kepercayaan Persepsian, Manfaat Persepsian, dan Kualitas Situs Persepsian, pada Sikap Konsumen terhadap Belanja Online. Skripsi Prodi Sarjana. Fakultas Ekonomika dan Bisnis. Yogyakarta: Universitas Gadjah Mada.
- Sahney, S; Archana, S; and Rajani, B. (2008). Consumer Attitude towards online retail shopping in the indian context, *Journal of Consumer Behavior*, Vol 3, No. 4, pp. 34-68.
- Sekaran, U. and Bougie, R. (2010). *Research Methods for Business, A Skill Building Approach*, 5th ed, Chichester, WS: John Wiley and Sons, Ltd.
- Sharma, G.and Lijuan, W. (2015). The effect of online service quality of e-commerce website on user satisfaction, *The Electronic Library*, Vol. 3, No. 33, pp. 478-485.
- Syaifullah dan Soemantri, O. D. (2016). Pengukuran kualitas *website* menggunakan metode webqual 4.0, *Jurnal Rekayasa dan Manajemen Sistem Informasi*, Vol. 2, No. 1.
- Szymanski, D. M. and Hise, R. T. (2000). E-Satisfaction: An Initial Examination. *Journal of Retailing*, Vol. 76, No.3,pp. 309-322.
- Tomlinson, E.C. and Mayer, R.C. (2009). The rolr of casual attribution dimensions in trust repair, *Academy of management review*, Vol. 34, No. 1, pp. 35-104.
- Torkzadeh, G. and Dhillon, G. (2002). Measuring Factors that Influence the Success of Internet Commerce, *Information Systems Research*, Vol. 13, No. 2, pp.187– 204.
- Van der Heijden, H; Verhagen, T; and Creemers, M. (2003). Understanding online purchase intention: contribution from technology and trust perspective, *European Journal of Information System*, Vol. 12, No. 1, pp. 41-48.
- Wang, S; Simon, W; and Ming, T.W. (2006). Shopping online or not? Cognition and personality matters, *Journal of Theoretical and applied electronic Commerce Research*, Vol. 1, No. 3, pp. 68-80.
- Wolfenbarger, M. and Gilly, M. C. (2003). eTailQ: dimensionalizing, measuring and predicting etail quality. *Journal of retailing*. Vol. 79, No. 3, pp. 183-198.
- Zhou, T. (2011). Examining the critical success factors of mobile *website* adoption. *Online Information Review*. Vol. 35, No. 4, pp. 636-652.