

Index

1. Power factor				
.....				
9				
1.1 Definition and calculations				
.....				
10				
1.2 "leading" or "lagging" power factors				
.....				
11				
1.3 Power factor measurement				
.....				
11				
1.4 Linear and nonlinear loads				
.....				
13				
1.5 Non-sinusoidal components				
.....				
15				
1.6 Switched-mode power supply				
.....				
15				
2. Power factor for three-phase and single motor				
.....				
16				
How inductive motors work 2.1				
.....				
17				
Examples of inductive motors that benefit from PF correction				
.....				
17 2.2				
2.3 Calculation of power factor for a three-phase motor				
.....				
17				
3. Importance of power factor in distribution systems				
.....				
20				
4. Passive power factor correction				
.....				
21				
5. Active power factor correction				
.....				
22				
5.1 Slow switching method				
.....				
23				
5.2 High frequency method				
.....				
24				
6. Why improve poor power factor				
.....				
26				
7. Modern techniques for improving power factor				
.....				
28				

7.1 Static var compensator (svc)	29
7.2 Fixed capacitor	31
7.3 Switched capacitor	31
7.4 Automatic power factor correction unit	32
7.5 Static synchronous compensator (STATCOM)	33
7.6 Modulated power filter capacitor compensator	35
8. Advantages of power factor correction	36
9. Disadvantages of low power factor	36
10. Case study: brick manufacturer	37
11. Power system harmonics	39
11.1 What causes harmonics	39
11.2. Effect of harmonics on waveform	41
12. What do harmonics do	42
12.1. Recall the Fourier series	42
13. How to quantify harmonic distortion	44
13.1. Calculation of THD	44
14. Sources of harmonics	46
15. Effects of harmonics	46

16. How can harmonics be reduced.....	48
16.1. Harmonic mitigating transformers	
.....	48
16.2. Phase shifting (zig-zag) transformers	49
16.3. Harmonic filter banks	
.....	51
16.4. For VFD and UPS specifically	
.....	52
16.5. Proper grounding	
.....	53
16.6. Isolate harmonic loads on separate circuits	53
17. Harmonics evaluation procedure.....	54
18. Simplified distribution system diagram.....	55
19. Energy optimization by kvar	
KEC.....	65
19.1. Benefits of KEC	
.....	65
19.2. Principle of operation	
.....	66
19.3. Specifications of the KEC	
.....	67
19.4. KEC installation	
.....	68

Conclusion

References

Abstract

The performance of the inductive machines can be improved by implementing modern PFC techniques which are more effective and optimizing, the corrected Power Factor can be enhanced and close to unity.

And by implementing our techniques, reduction of tripled, 5th and 7th harmonics can be achieved, hence the total harmonic distortion is decreased and power quality is increased for all loads.

The net result is that the electrical distribution system predictably becomes electromagnetically compatible with the electronic loads (e.g. personal computers) it has to supply.

Finally, Overall performance of the drive will be improved by using modern PFC techniques and harmonics reduction methods.

Introduction

One of the important problems of today's energy utilization is power quality, if the power is not utilized properly; large voltage variations occur in transmission and distribution (T&D) systems resulting in low utilization efficiency for users. Therefore, operating power factor of T&D systems must be corrected.

Since the reason of low power factor operation of T&D systems is the reactive power requirements of loads, this problem should be eliminated at load terminals. Thus, the required reactive power is supplied from another source, usually compensating capacitors, at load terminals and the reactive power loading of T&D systems is reduced. The control of reactive power flow and voltage magnitude in high voltage alternating current (HVAC) systems has become an important task.

On other hand, Harmonics are known to cause serious operational problems for users as well as building maintenance personnel. Until recently, no effective methods have been proposed that can universally deal with 3rd, 5th and 7th harmonics during the design and specification stage of three phase four wire electrical distribution systems.

Nowadays, modern and more effective techniques are used to optimize poor power factor and reduce harmful harmonics.

Power factor correction



1. Power factor

Power factor of an AC electrical power system is defined as:

"The ratio of the real power flowing to the load to the apparent power in the circuit, and is a dimensionless between 0 and 1".

Real power is:

"The capacity of the circuit to perform work in a particular time"

Reactive power is:

"The non-working power caused by the magnetizing current required to operate & sustain the magnetism in the device"

Apparent power is:

"The Product of the current and voltage of the circuit"

The ratio of active power to the resultant power, called: **power factor**.

Due to energy stored in the load and returned to the source, or due to a non-linear load that distorts the wave shape of the current drawn from the source, the apparent power will be greater than the real power. In an electric power system, a load with a low power factor draws more current than a load with a high power factor for the same amount of useful power transferred.

The higher currents increase the energy lost in the distribution system, and require larger wires and other equipment.

Because of the costs of larger equipment and wasted energy, electrical utilities will usually charge a higher cost to industrial or commercial customers where there is a low power factor.

Linear loads with low power factor (such as induction motors) can be corrected with a passive network of capacitors or inductors. Non-linear loads, such as rectifiers, distort the current drawn from the system.

In such cases, active or passive power factor correction may be used to counteract the distortion and raise the power factor.

The devices for correction of the power factor may be at a central substation, spread out over a distribution system, or built into power-consuming equipment.

1.1 Definition and calculations:

AC power flow has the three components: real power (also known as active power) (P), measured in watts (W); apparent power (S), measured in volt-amperes (VA); and reactive power (Q), measured in reactive volt-ampere (var).

To understand the definition of power factor, we must first look at the power relationships. The load will have a real power component (p) and a reactive power component (Q).

The vector sum of these two power components is the apparent power to the load. (S)

We are now able to define power factor for a linear load:

$$\text{Power Factor} = \frac{\text{RealPower}(P)}{\text{ApparentPower}(S)} = \cos \phi$$

Consequently, once the apparent power (S) is measured as $V_{rms} \times I_{rms}$, the real power (P) and the reactive power (Q) can be determined by:

$$\text{Reactive Power} = Q = S \sin \phi$$

For the nonlinear load case, things get more complex.

The phase shift cannot easily be measured due to the non-sinusoidal nature of the current waveform.

Consequently, for the nonlinear case, the power factor is best defined as follows:

$$\text{Power Factor} = \frac{\text{RealPower}(P)}{\text{ApparentPower}(S)}$$

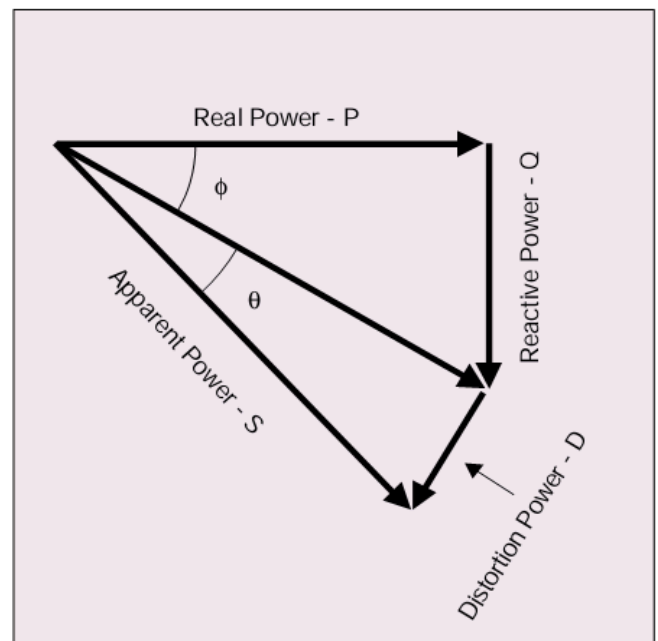

Figure 1.1: Power diagram of linear load

Distortion power is similar to the reactive power in that it does not contribute directly to the useful power dissipated in the load, but rather adds to the reactive power to create a higher value of apparent power.

The additional angle between the real and apparent powers due to a non-sinusoidal current waveform is defined as the distortion angle, θ . This allows another form of the definition for power factor.

$$\text{Power Factor} = \frac{\text{Real Power (P)}}{\text{Apparent Power (S)}} = k_d k_\phi$$

Where k_d and k_ϕ Are both factors between 0 and 1 and

$$k_d = \text{distortion factor} = \frac{I_{1\text{rms}}}{I_{\text{rms}}}$$

$$k_\phi = \text{displacement factor} = \cos \phi_1$$

Where, $I_{1\text{rms}}$ = fundamental current

I_{rms} = total current

ϕ_1 = phase shift of fundamental current

1.2 "Leading" or "Lagging" Power Factors

Power factors are usually stated as "leading" or "lagging" to show the sign of the phase angle, with a purely resistive load current and voltage changes polarity in step and the power factor will be 1. Electrical energy flows in a single direction across the network in each cycle.

Inductive loads: transformers, motors and wound coils; consumes reactive power with current waveform lagging the voltage.

Capacitive loads: capacitor banks or buried cables; generates reactive power with current phase leading the voltage.

1.3 Power Factor Measurement

Power factor can measure by using power factor meter which is well known in power industry.

Power factor can also be calculated by installing watt meter along with the Ampere meter and volt meter by using the power factor basic formula.

$$\text{Power factor} = \frac{\text{Actual Power}}{\text{Apparent power}}$$

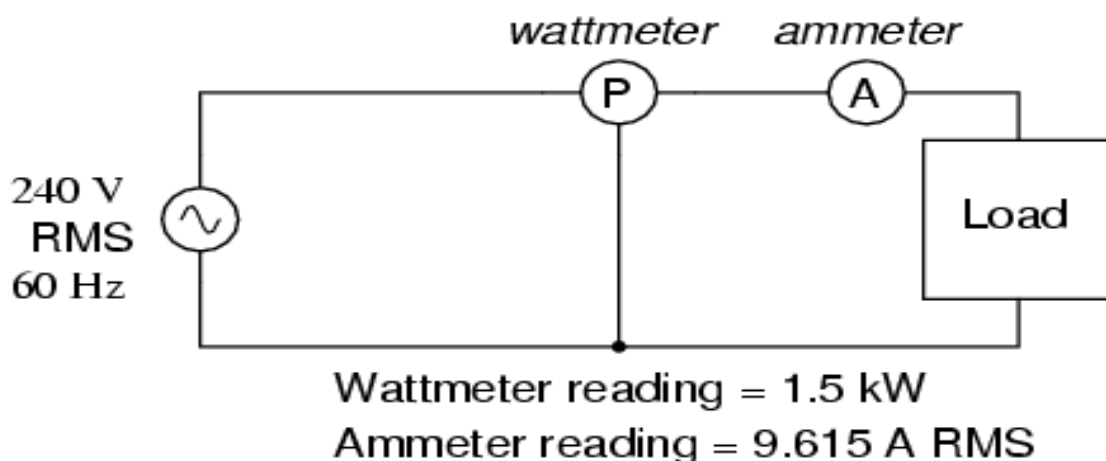

Figure 1.3: calculating PF by meters

$$S = IE$$

$$S = (9.615 \text{ A})(240 \text{ V})$$

$$S = 2.308 \text{ kVA}$$

$$\text{Power factor} = \frac{P}{S}$$

$$\text{Power factor} = \frac{1.5 \text{ kW}}{2.308 \text{ kVA}}$$

$$\text{Power factor} = 0.65$$

- ✓ The power factor in a single-phase circuit (or balanced three-phase circuit) can be measured with the wattmeter-ammeter-voltmeter method, where the power in watts is divided by the product of measured voltage and current. The power factor of a balanced poly phase circuit is the same as that of any phase. The power factor of an unbalanced poly phase circuit is not uniquely defined.
- ✓ A direct reading power factor meter can be made with a moving coil meter of the electro-dynamics type, carrying two perpendicular coils on the moving part of the instrument. The field of the instrument is energized by the circuit current flow. The two moving coils, A and B, are connected in parallel with the circuit load. One coil, A, will be connected through a resistor and the second coil, B, through an inductor, so that the current in coil B is delayed with respect to current in A. At unity power factor, the current in A is in phase with the circuit current, and coil A provides maximum torque, driving the instrument pointer toward the 1.0 mark on the scale. At zero power factor, the current in coil B is in phase with circuit current, and coil B provides torque to drive the pointer towards 0. At intermediate values of power factor, the torques provided by the two coils adds and the pointer takes up intermediate positions.
- ✓ Another electromechanical instrument is the polarized-vane type. In this instrument a stationary field coil produces a rotating magnetic field, just like a poly phase motor. The field coils are connected either directly to poly phase voltage sources or to a phase-shifting reactor if a single-phase application. A second stationary field coil, perpendicular to the voltage coils, carries a current proportional to current in one phase of the circuit. The moving system of the instrument consists of two vanes that are magnetized by the current coil. In operation the moving vanes take up a physical angle equivalent to the electrical angle between the voltage source and the current source.

This type of instrument can be made to register for currents in both directions, giving a four-quadrant display of power factor or θ angle.

- ✓ Digital instruments can be made that either directly measure the time lag between voltage and current waveforms and so calculate the power factor, or by measuring both true and apparent power in the circuit and calculating the quotient. The first method is only accurate if voltage and current are sinusoidal; loads such as rectifiers distort the waveforms from the sinusoidal shape.

1.4 Linear and Nonlinear loads

A high power factor is generally desirable in a transmission system to reduce transmission losses and improve voltage regulation at the load.

It is often desirable to adjust the power factor of a system to near 1.0.

When reactive elements supply or absorb reactive power near the load, the apparent power is reduced.

Power factor correction may be applied by an electrical power transmission utility to improve the stability and efficiency of the transmission network. Individual electrical customers who are charged by their utility for low power factor may install correction equipment to reduce those costs.

Power factor correction brings the power factor of an AC power circuit closer to 1 by supplying reactive power of opposite sign, adding capacitors or inductors that act to cancel the inductive or capacitive effects of the load, respectively.

For example, the inductive effect of motor loads may be offset by locally connected capacitors. If a load had a capacitive value, inductors (also known as *reactors* in this context) are connected to correct the power factor.

In the electricity industry, inductors are said to *consume* reactive power and capacitors are said to *supply* it, even though the energy is just moving back and forth on each AC cycle. The reactive elements can create voltage fluctuations and harmonic noise when switched on or off, They will supply or sink reactive power regardless of whether there is a corresponding load operating nearby, increasing the system's no-load losses. In the worst case, reactive elements can interact with the system and with each other to create resonant conditions, resulting in system instability and severe overvoltage fluctuations.

As such, reactive elements cannot simply be applied without engineering analysis.

A non-linear load on a power system is typically a rectifier (such as used in a power supply), or some kind of arc discharge device such as a fluorescent lamp, electric welding machine, or arc furnace.

Because current in these systems is interrupted by a switching action, the current contains frequency components that are multiples of the power system frequency.

Distortion power factor is a measure of how much the harmonic distortion of a load current decreases the average power transferred to the load. Sinusoidal voltage and non-sinusoidal current give a distortion power factor of 0.75 for this computer power supply load.

In Figure 2.1 an Instantaneous and average power calculated from AC voltage and current ($\cos \varphi = 0, \varphi = 90$) with a zero power factor

The blue line shows all the power is stored temporarily in the load during the first quarter cycle and returned to the grid during the second quarter cycle, so no real power is consumed.

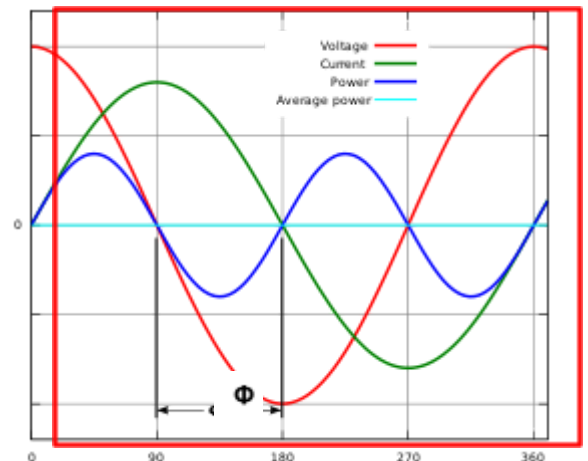

Figure 1.4 A
Zero power factor

In figure 1.4 B : Instantaneous and average power calculated from AC voltage and current with a lagging power factor ($\varphi = 45, \cos \varphi = 0.71$).

-The blue line shows some of the power is returned to the grid during the part of the cycle labeled.

In a purely resistive AC circuit, voltage and current waveforms are in step (or in phase), changing polarity at the same instant in each cycle. All the power entering the load is consumed.

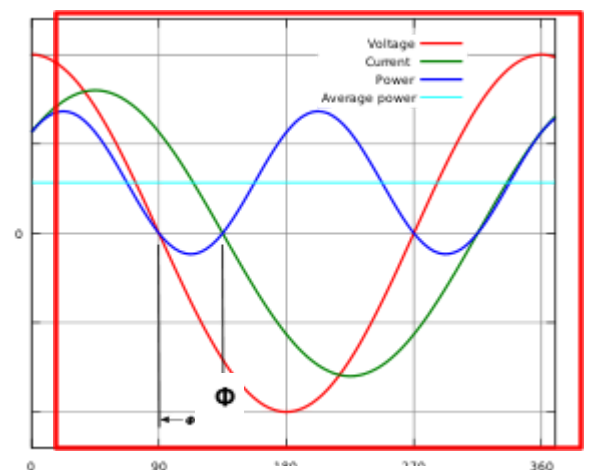

Figure 1.4 B
Lagging power factor

Where reactive loads are present, such as with capacitors or inductors; energy storage in the loads results in a time difference between the current and voltage waveforms. During each cycle of the AC voltage, extra energy, in addition to any energy consumed in the load, is temporarily stored in the load.

In electric or magnetic fields, and then returned to the power grid a fraction of a second later in the cycle. The "ebb and flow" of this nonproductive power increases the current in the line.

Thus, a circuit with a low power factor will use higher currents to transfer a given quantity of real power than a circuit with a high power factor.

A linear load does not change the shape of the waveform of the current, but may change the relative timing (phase) between voltage and current.

-Circuits containing purely resistive heating elements (filament lamps, cooking stoves, etc.) have a power factor of 1.0.

-Circuits containing inductive or capacitive elements (electric motors, solenoid valves, lamp ballasts, and others) often have a power factor below 1.0.

1.5 Non-sinusoidal components

Non-linear loads change the shape of the current waveform from a sine wave to some other form and create harmonic currents in addition to the original (fundamental frequency) AC current.

Filters consisting of linear capacitors and inductors can prevent harmonic currents from entering the supplying system.

In linear circuits having only sinusoidal currents and voltages of one frequency, the power factor arises only from the difference in phase between the current and voltage. This is "displacement power factor"; the concept can be generalized to a total, distortion, or true power factor where the apparent power includes all harmonic components. This is of importance in practical power systems that contain non-linear loads such as rectifiers, some forms of electric lighting, electric arc furnaces, welding equipment, switched-mode power supplies and other devices.

A typical multimeter will give incorrect results when attempting to measure the AC current drawn by a non-sinusoidal load; the instruments sense the average value of a rectified waveform. The average response is then calibrated to the effective, RMS value. An RMS sensing multimeter must be used to measure the actual RMS currents and voltages (and therefore apparent power).

To measure the real power or reactive power, a meter designed to work properly with non-sinusoidal currents must be used.

1.6 Switched-mode power supply

A particularly important class of non-linear loads is the millions of personal computers that typically incorporate switched-mode power supplies (SMPS) with rated output power ranging from a few watts to more than 1 kW.

Historically, these very-low-cost power supplies incorporated a simple full-wave rectifier that conducted only when the mains instantaneous voltage exceeded the voltage on the input capacitors.

This leads to very high ratios of peak-to-average input current, which also lead to a low distortion power factor and potentially serious phase and neutral loading concerns.

A typical switched-mode power supply first makes a DC bus, using a bridge rectifier or similar circuit.

The output voltage is then derived from this DC bus. The problem with this is that the rectifier is a non-linear device, so the input current is highly non-linear.

That means that the input current has energy at harmonics of the frequency of the voltage. This presents a particular problem for the power companies, because they cannot compensate for the harmonic current by adding simple capacitors or inductors, as they could for the reactive power drawn by a linear load.

Many jurisdictions are beginning to legally require power factor correction for all power supplies above a certain power level.

Regulatory agencies have set harmonic limits as a method of improving power factor.

Declining component cost has hastened implementation of two different methods. To comply with current EU standard EN61000-3-2, all switched-mode power supplies with output power more than 75 W must include passive PFC, at least.

80 Plus power supply certification requires a power factor of 0.9 or more.

2. Power Factor for Three-Phase and single Motor

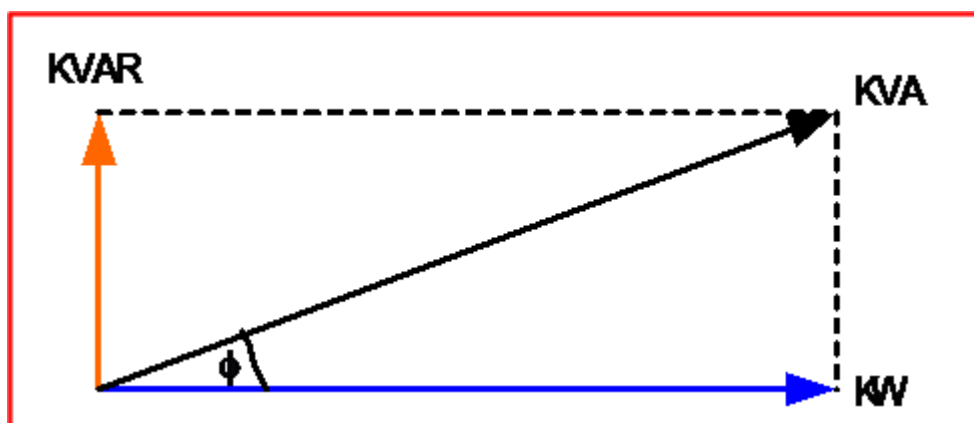

Figure 2: relation between P, Q and S

Three phase calculations:

$$\text{KVA} = \text{Line Current} \times \text{Line Voltage} \times \sqrt{3} / 1000$$

$$\text{KVA} = I \times V \times 1.732 / 1000$$

$$\text{KW} = \text{True Power}$$

$$\text{PF} = \text{Power Factor} = \text{Cos}(\phi)$$

$$KW = KVA \times PF = V \times I \times \sqrt{3} \times pf$$

$$KVAR = KVA \times \text{Sine } (\emptyset) = KVA \times \sqrt{1 - PF^2}$$

Single phase calculations:

$$KVA = \text{Line Current} \times \text{phase Voltage} / 1000$$

$$KVA = I \times V / 1000$$

$$KW = \text{True Power}$$

$$PF = \text{Power Factor} = \text{Cos } (\emptyset)$$

$$KW = KVA \times PF = V \times I \times \sqrt{3} \times pf$$

$$KVAR = KVA \times \text{Sine } (\emptyset) = KVA \times \sqrt{1 - PF^2}$$

2.1 How Inductive Motors Work :

AC motors require reactive power to develop magnetic fields in addition to real power which actually does the work.

$$\text{Reactive Power (kVars)} + \text{Real Power (kW)} = \text{Apparent Power (kVa)}$$

2.2 Examples of inductive motors that benefit from PF correction:

- 1-Compressors
- 2-Pumps
- 3-A/C units
- 4-Chillers
- 5-Dust collectors
- 6-Conveyors
- 7-Etc.

2.3 Calculation of Power Factor for a Three-Phase Motor

The total power required by an inductive device as a motor or similar consists of Active (true or real) power (measured in kilowatts, kW).

Reactive power - the nonworking power caused by the magnetizing current, required to operate the device (measured in kilovars, Kvar)

The power factor for a three-phase electric motor can be expressed as:

$$PF = P / [\sqrt{3} U I]$$

Where:

PF = power factor

$P = \text{power applied (W, watts)}$

$U = \text{voltage (V)}$

$I = \text{current (A, amps)}$

Power (hp)	Speed (rpm)	Power Factor		
		1/2 load	3/4 load	full load
0 - 5	1800	0.72	0.82	0.84
5 - 20	1800	0.74	0.84	0.86
20 - 100	1800	0.79	0.86	0.89
100 - 300	1800	0.81	0.88	0.91

$1 \text{ hp} = 745.7 \text{ W}$

Typical Motor Power Factors

Example 1:

To get 1 kW of real power, if the power factor is unity, 1 kVA of apparent power needs to be transferred ($1 \text{ kW} \div 1 = 1 \text{ kVA}$). At low values of power factor, more apparent power needs to be transferred to get the same real power. To get 1 kW of real power at 0.2 power factor, 5 kVA of apparent power needs to be transferred ($1 \text{ kW} \div 0.2 = 5 \text{ kVA}$). This apparent power must be produced and transmitted to the load in the conventional fashion, and is subject to the usual distributed losses in the production and transmission processes.

Example 2:

Let's take an example. A 3/4 hp electric motor has a power factor of .85. The nameplate current is 10 Amps at 115 Volts, or 1150 Volt Amps.

Apparent power = **1150** Volt Amps

Active power (P) = **0.85 * 1150 = 977.5** Watts

Reactive Power (Q) = $\sqrt{(1150)^2 - (977)^2} = \mathbf{605 \text{ VAR}}$

So, we need about 600 var of power factor correction. I'm rounding to a couple digits, because, in reality, it's unlikely that the power factor is not known to more accuracy, nor will any of the PFC components be that precise. (10% accuracy would be quite good for a capacitor). Now, assume we want to put the capacitor in parallel with the motor: Calculating the required impedance from

$Q = \frac{E^2}{X}$, where Q is the reactive power needed:

$$600 = \frac{115^2}{X}, X = \frac{115^2}{600} = 22 \text{ ohms}$$

$$C = 1 / (2 * \pi * f * X) = 1 / (377 * 22) = 120 \mu\text{F}$$

This is a fairly large capacitor in a constant duty environment (i.e. motor run, as opposed to motor start, where the capacitor is only in the circuit for a short time). You can calculate the RMS current through the capacitor either by dividing the VARs by the line voltage (600/115) or by dividing line voltage by reactance (115/22); both come out at around 5 1/4 Amps, so you'd want a capacitor rated at somewhat more current (e.g. 7-10 A). The capacitor's series resistance should be pretty low, or it will dissipate a fair amount of energy. If the dissipation factor were 1%, you'd be dissipating about 6 Watts in the capacitor. One can also put the PFC capacitor in series with the load. In this case the capacitor would carry the entire load current of 10A, but, the required value is different. For series compensation, you'd determine the series equivalent of the load (we used a parallel model, above). For the series model, you use currents, instead of voltages:

$$600 \text{ VAR} = I^2 * X, 600 = 10 * 10 * X, X = 6 \text{ ohms}$$

And converting impedance to a capacitance: $C = 1 / (377 * 6) = 440 \mu\text{F}$. So, not only would the capacitor be larger, but it would need to carry the entire load current. For this example, at least, parallel PFC seems to be a better approach. Only if the power factor was very poor, so the reactive impedance was quite large (and the corresponding capacitance low) would series compensation seem to be useful.

If the line voltage were higher, the correction impedance would be increased as the square of the line voltage. The capacitance would be reduced as the square of the line voltage. That is, if the same motor were run off 230 volts, the capacitor would only need to be about 30 19 And if we were to do power factor

compensation at the distribution voltage of 4160 volts (for example), you would only need about .1 uF. This is why power factor correction is usually done in the distribution network at MV or HV, and not at the end voltage.

Example 3: Compressor Power Factor Correction

Real Power Calculation:

Volts x Amps x PF = Watts

$$460 \times 56 \times 0.55 = 14168 \text{ watts}$$

After PF correction

$$460 \times 23 \times 0.98 = 10368 \text{ watts}$$

Reduction of 3800 Watts = 27%

Line % Reduction: (N2= new efficiency N1= old efficiency)

$$N2 - N1 / N2$$

$$0.98 - 0.55 / 0.98 = 44\% \text{ current line reduction}$$

3. Importance of power factor in distribution systems

Power factors below 1.0 require a utility to generate more than the minimum volt-amperes necessary to supply the real power (watts). This increases generation and transmission costs. For example, if the load power factor were as low as 0.7, the apparent power would be 1.4 times the real power used by the load.

Line current in the circuit would also be 1.4 times the current required at 1.0 power factor, so the losses in the circuit would be doubled (since they are proportional to the square of the current).

Alternatively all components of the system such as generators, conductors, transformers, and switchgear would be increased in size (and cost) to carry the extra current.

Utilities typically charge additional costs to customers who have a power factor below some limit, which is typically 0.9 to 0.95. Engineers are often interested in the power factor of a load as one of the factors that affect the efficiency of power transmission.

With the rising cost of energy and concerns over the efficient delivery of power, active PFC has become more common in consumer electronics.

Current Energy Star guidelines for computers (ENERGY STAR Program Requirements for Computers Version 5.0) call for a power factor of ≥ 0.9 at 100% of rated output in the PC's power supply. According to a white paper authored by Intel and the U.S. Environmental Protection Agency, PCs with internal power supplies will require the use of active power factor correction to meet the ENERGY STAR 5.0 Program Requirements for Computers. In Europe, IEC 555-2 requires power factor correction to be incorporated into consumer products.

4. Passive Power factor Correction

Passive PFC techniques can be used to improve the power factor of nonlinear loads, such as power converters with off-line rectifiers.

The diagram shows input wave shaping circuit consisting of an inductor and a capacitor. This type of circuit will help the input current waveform become more sinusoidal, but not completely so.

Some distortion will remain, and the power factor can be improved to a maximum of perhaps 0.9.

Active techniques can do much better, achieving power factors of up to 0.99.

The other major shortcoming of the passive approach in this application is the need for an inductor that operates at the line frequency.

The low frequency inductor is physically large and heavy.

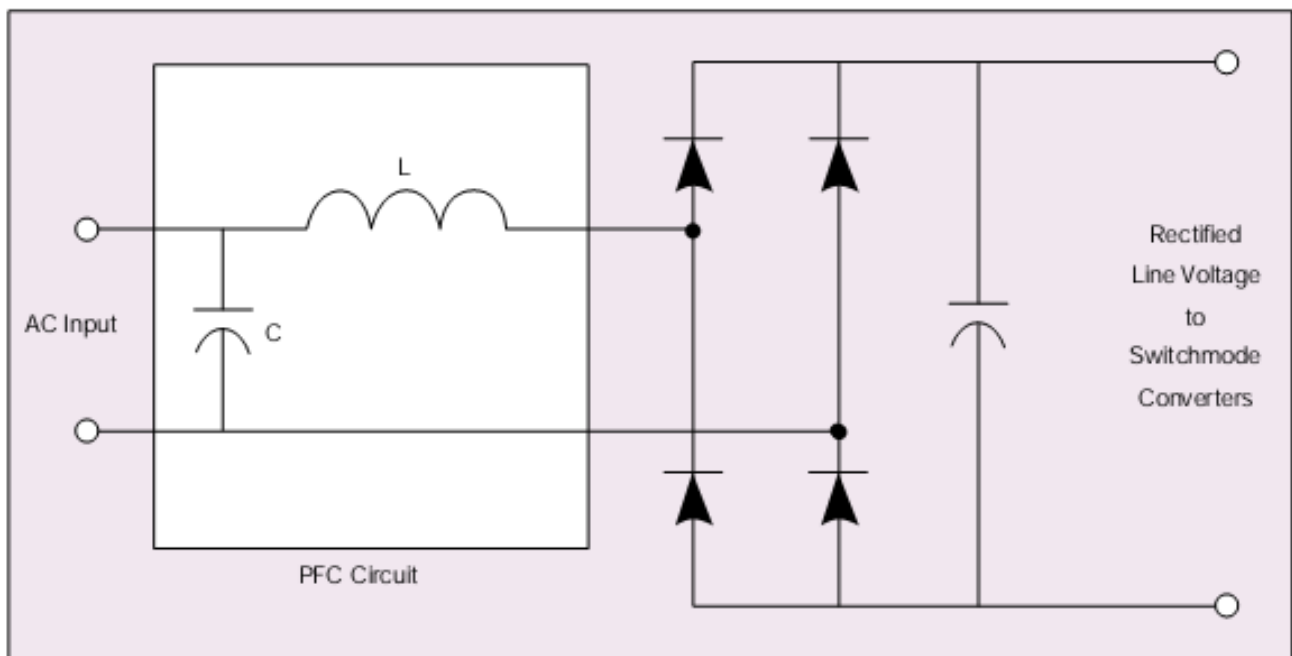

Advantages	Disadvantages
Simple	Line Frequency Components are Large and Heavy

5. Active Power Factor Correction

Active PFC circuits are based on switch mode converter techniques and are designed to compensate for distortion as well as displacement on the input current waveform, they tend to be significantly more complex than passive approaches, but this complexity is becoming more manageable with the availability of specialized control ICs for implementing active PFC.

Active PFC operates at frequencies higher than the line frequency so that compensation of both distortion and displacement can occur within the timeframe of each line frequency cycle, resulting in corrected power factors of up to 0.99.

Active approaches can be divided into two classes:

- Slow switching method.
- High frequency method.

5.1 Slow switching method:

The slow switching approach can be thought of as a mix of passive and active techniques, both in complexity and performance.

The most common implementation is shown in Figure, and includes the line frequency inductor L , The inductor is switched during the operating cycle, so this is considered an active approach, even though it operates at a relatively low frequency - typically twice the line frequency.

This is a boost circuit in the sense that the AC zero crossing is sensed and used to close the switch that places the inductor across the AC input.

Consequently, the inductor current ramps up during the initial portion of the AC cycle. At time T_1 , the switch is opened so that the energy stored in the inductor can freewheel through the diodes to charge the capacitor. This energy transfer occurs from T_1 to T_2 and the input current drops as a result.

From T_2 to T_3 the input current rises again because the line voltage is larger than the bulk capacitor voltage. From T_3 to T_4 , the current reduces to zero.

Consequently, the conduction angle as seen at the input is much longer than that of a non-compensated off-line rectifier, resulting in lower distortion and a power factor of up to 0.95.

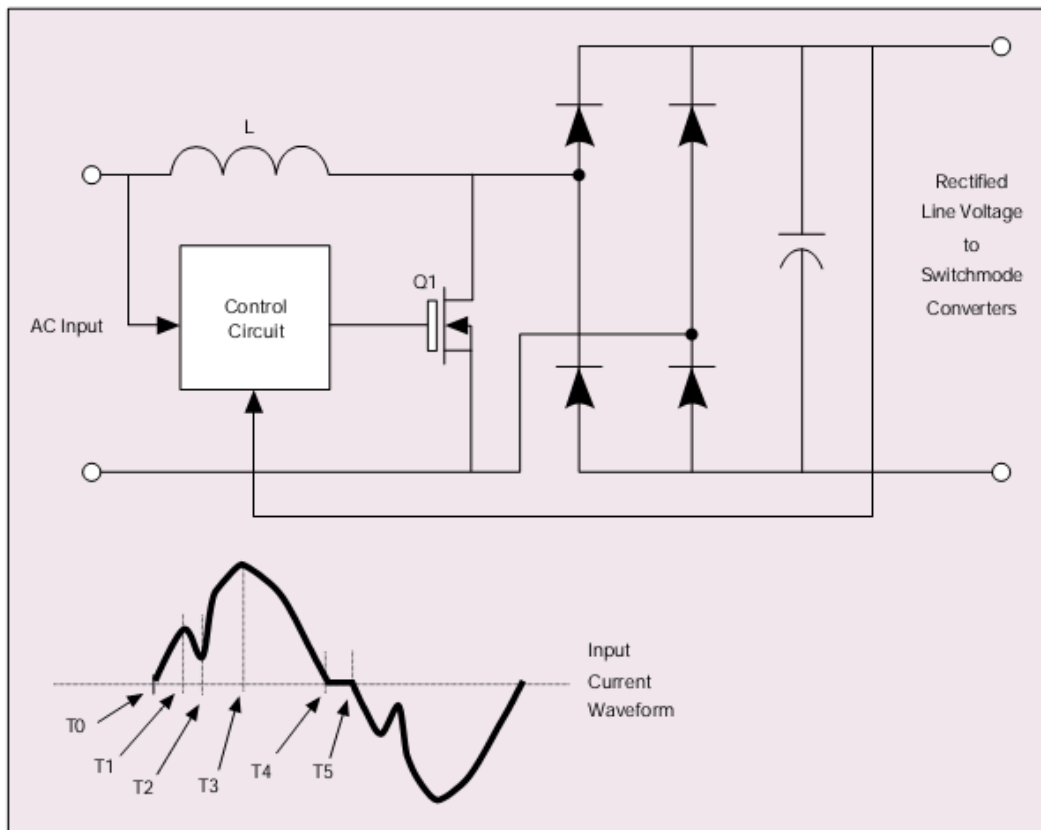

Figure 5.1

Boost circuit for active PFC: "Slow switching"

The previous circuit is much simpler than the high frequency circuit to be discussed next, but has a few shortcomings in addition to its limited maximum power factor. Since the

switching activity is usually in the 100Hz to 500Hz range, there can be audible noise associated with its operation. Also, a large and heavy line frequency inductor is required.

Advantages	Disadvantages
Simple	Line Frequency Components are Large and Heavy
Cost Effective at Low Power	Cannot Completely Correct Nonlinear Loads - 95% Maximum Power Factor
High Efficiency - 98% Typical	Audible Noise
Low EMC due to Inductor	

Advantages and Disadvantages of slow switching method

5.2 High frequency method:

Conceptually, any of the popular basic converter topologies, including the flyback and buck, could be used as a PFC stage. We will focus, however, on the boost topology since it is the most popular implementation. There are several possible control techniques that can be used to implement a Boost PFC converter, but the version shown in Figure is a good general representation of the concept and will be used here for illustration.

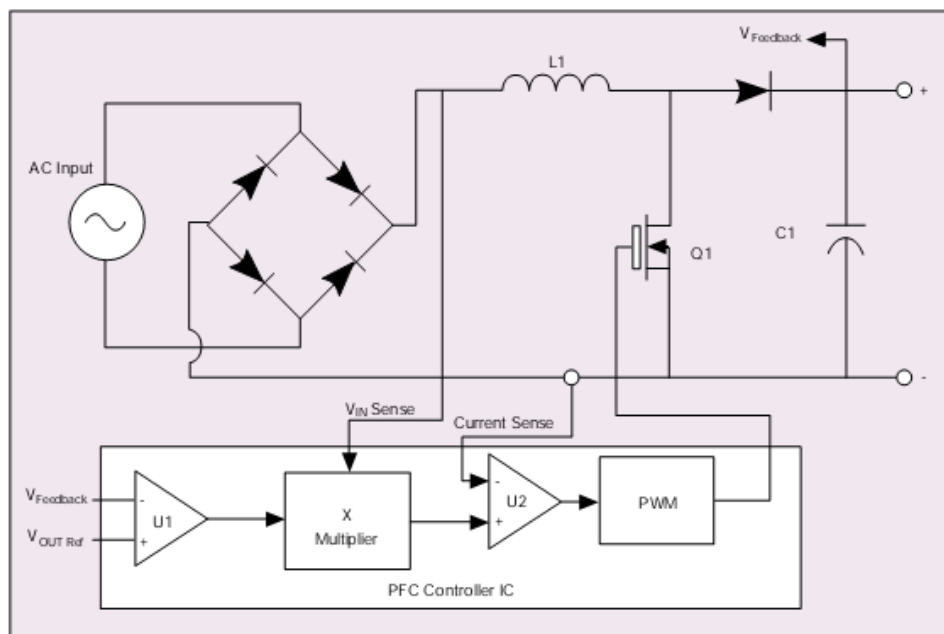

Figure 5.2 Boost circuit for active PFC: "High frequency"

Almost all present day boost PFC converters utilize a standard controller chip for the purposes of ease of design, reduced circuit complexity and cost savings.

These ICs are available from many of the analog IC suppliers and greatly simplify the process of achieving a reliable high-performance circuit. In order for the converter to achieve power factor correction over the entire range of input line voltages, the converter (in the PFC circuit) must be designed so that the output voltage, V_{OUT} , is greater than the peak of the input line voltage.

Assuming a maximum line voltage of 240 Vrms and allowing for at least a 10% margin results in a nominal V_{OUT} in the vicinity of 380 Vdc, V_{OUT} is regulated via feedback to the operational amplifier U_1 .

The sensed V_{IN} will be in the form of a rectified sine wave, which accurately reflects the instantaneous value of the input AC voltage. This signal is used as an input to the multiplier along with the V_{OUT} error voltage to formulate a voltage that is proportional to the desired current.

This signal is then compared with the sensed actual converter current to form the error signal that drives the converter switch Q_1 . The result is that the input current waveform will track the AC input voltage waveform almost perfectly. By definition, this constitutes a power factor approaching unity. The active boost circuit will correct for deficiencies in both displacement and distortion.

During operation of the converter, the duty cycle will vary greatly during each half cycle of the input AC wave form. The duty cycle will be the longest when the instantaneous value of the AC is near zero and will be very short during the peaks of each half cycle.

The voltage stress on the switch Q_1 is equal to only V_{OUT} , and the current levels are reasonable, resulting in an economical device selection. Since Q_1 is referenced to ground, its control and driver circuits are relatively straight forward and easy to implement.

The inductor L_1 assists in reducing EMC from the converter and in suppressing some input transients from the power line. It is not large enough in value, however, to be considered as protection from start-up inrush current, which must be provided by other methods.

Advantages	Disadvantages
<p>High Power Factor ≈ 0.99</p> <p>Corrects both Distortion and Displacement Autoranging</p> <p>Circuit includes Input Voltage</p> <p>Regulated V_{OUT}</p>	<p>Complexity</p> <p>V_{OUT} has to be $>$ Peak $V_{IN} \approx 380$ Vdc</p> <p>Cost for Low Power Applications</p> <p>Adds 2nd Conversion Stage in some cases and Decreases Efficiency</p>

6. Why Improve Poor Power Factor

- Utilities typically charge a penalty fee to customers with PF less than 90%.
- Uncorrected PF causes excessive loss in your distribution system.
- Excessive voltage drop causes overheating and premature failure of motors and other inductive equipment
- Energy savings realized
- Reduce carbon footprint.

Utility companies in many areas include a penalty charge in the electrical rate for low power factor. The installation of power factor capacitors on the user's electrical distribution system eliminates the necessity of paying premium rates to the utility company for poor power factor.

The savings the utility company derives in reduced generation, transmission and distribution costs are passed on to the user in the form of lower electrical charges. Three of the more common ways utility charges a user for poor power factor are based on:

- KW demand with a trigger point typically between 85% and 95%
- KVA demand
- KVAR demand

- The AC inductive motor typically operates at 80% efficiency when under full load, but the efficiency drops dramatically at lower loads.

- A typical inductive motor consumes over 80% of its purchase price in electricity over its life!

-System losses are also reduced through power factor correction by reducing the total current and power in the system. A 20% reduction in current will yield a 36% reduction in distribution system losses. In this situation, an energy savings of as much as 50% will be realized with the installation of power factor capacitors.

In addition, power factor capacitors decrease the distribution system voltage drops and fluctuations.

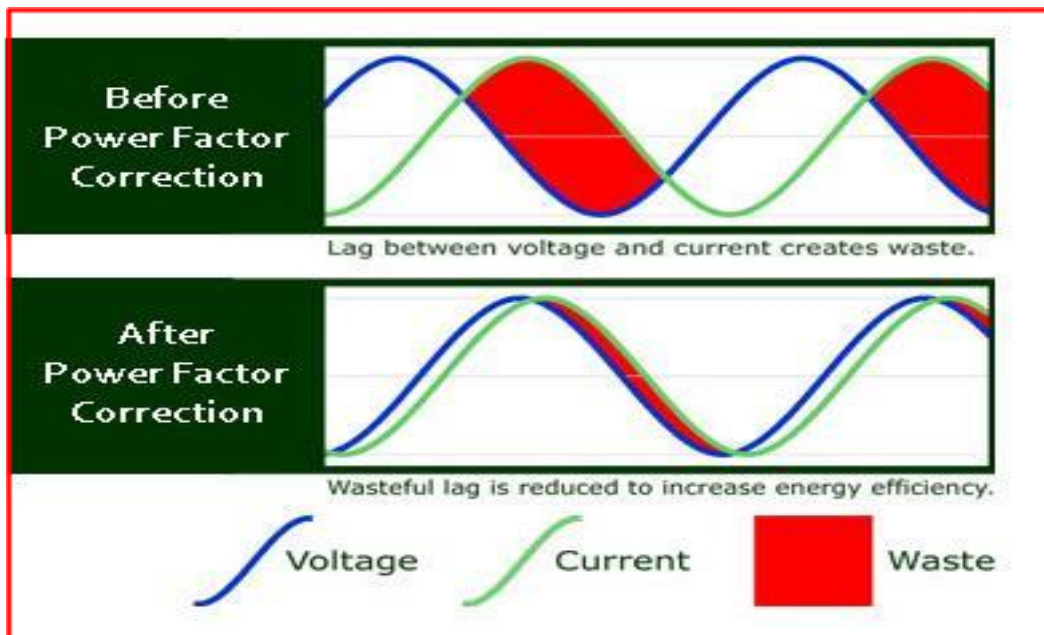

7. Modern techniques for improving power factor

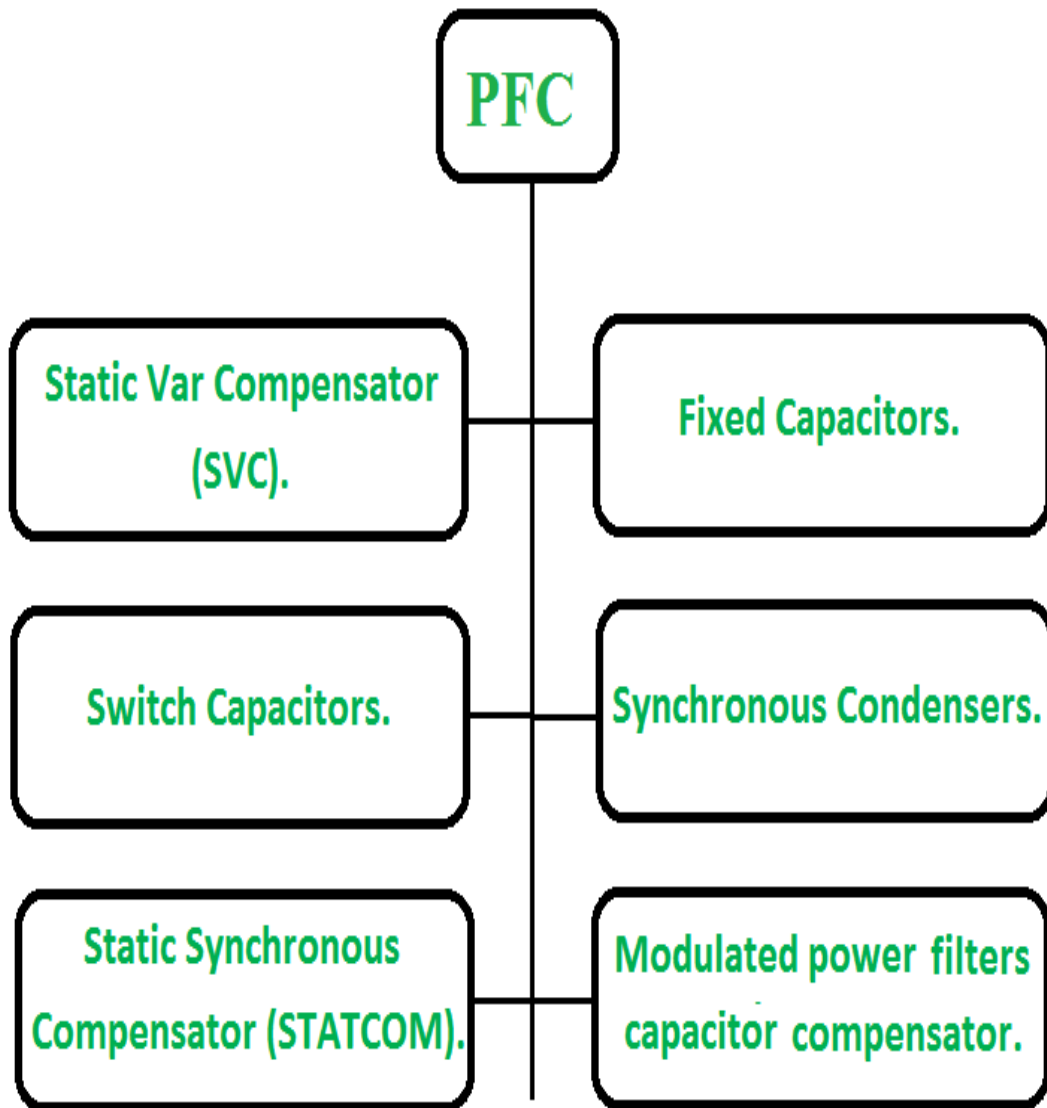

✓ 7.1 STATIC VAR COMPENSATOR (SVC):



Figure7.1A: SVC

The Static Var Compensator (SVC) is a shunt device of the Flexible AC Transmission Systems (FACTS) family using power electronics to control power flow and improve transient stability on power grids. The SVC regulates voltage at its terminals by controlling the amount of reactive power injected into or absorbed from the power system. When system voltage is low, the SVC generates reactive power (SVC capacitive). When system voltage is high, it absorbs reactive power (SVC inductive).

The SVC is an automated impedance matching device, designed to bring the system closer to unity power factor. SVCs are used in two main situations:

- Connected to the power system, to regulate the transmission voltage ("Transmission SVC")
- Connected near large industrial loads, to improve power quality ("Industrial SVC")

The variation of reactive power is performed by switching three-phase capacitor banks and inductor banks connected on the secondary side of a coupling transformer. Each capacitor bank is switched on and off by three thyristor switches (Thyristor Switched Capacitor or TSC). Reactors are either switched on-off (Thyristor Switched Reactor or TSR) or phase-controlled (Thyristor Controlled Reactor or TCR).

A rapidly operating Static Var Compensator (SVC) can continuously provide the reactive power required to control dynamic voltage swings under various system conditions and thereby improve the power system transmission and distribution performance.

Typically, an SVC comprises one or more banks of fixed or switched shunt capacitors or reactors, of which at least one bank is switched by thyristors. Elements which may be used to make an SVC typically include:

- Thyristor controlled reactor (TCR), where the reactor may be air- or iron-cored
- Thyristor switched capacitor (TSC)
- Harmonic filter(s)
- Mechanically switched capacitors or reactors (switched by a circuit breaker)

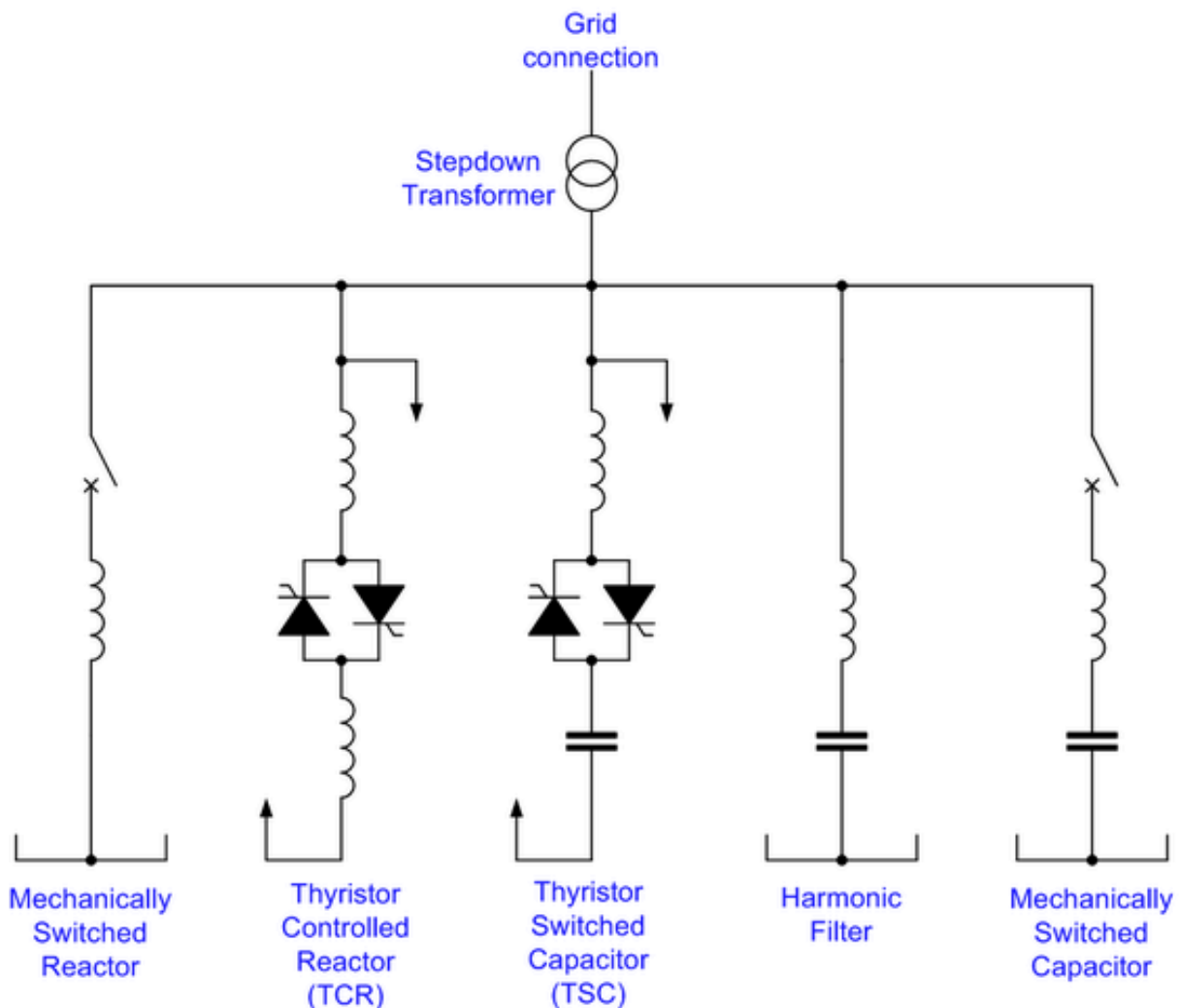

Figure 7.1B: SVC installation

Installing an SVC at one or more suitable points in the network will increase transfer capability through enhanced voltage stability, while maintaining a smooth voltage profile under different network conditions. In

Addition, an SVC can mitigate active power oscillations through voltage amplitude modulation.

In industrial applications, SVCs are typically placed near high and rapidly varying loads, such as arc furnaces, where they can smooth flicker voltage.

✓ 7.2 FIXED CAPACITOR:



Figure7.2: FIXED CAPACITOR

Where the load does not change or where the capacitor is switched with the load, such as the load side of an ideally suited for power factor correction in applications Motor contactor. It is suitable for locations using Induction motors, like food processing plants, or where small multiple loads require reactive power compensation.

Each Fixed Capacitor Bank is designed for high reliability and long life. These products are designed for applications that do not contain harmonic generating.

Note: when capacitor is connected to the load side of the motor over current protection, fused disconnects or breaker protection is not required. Fuses are recommended for all other indoor applications.

Advantages: Most economical, fewer installations.

✓ 7.3 SWITCHED CAPACITOR:



Figure7.3: SWITCHED CAPACITOR

It is suited for centralized power factor correction in applications where plant loading is constantly changing, resulting in the need for varying amounts of reactive power. An advanced microprocessor-based reactive power controller measures plant power factor via

a single remote current transformer (included), and switches capacitor modules in and out of service to maintain a user-selected target power factor. Switched capacitor typically applied at service entrance or near fluctuating loads.

✓ 7.4 Automatic power factor correction unit

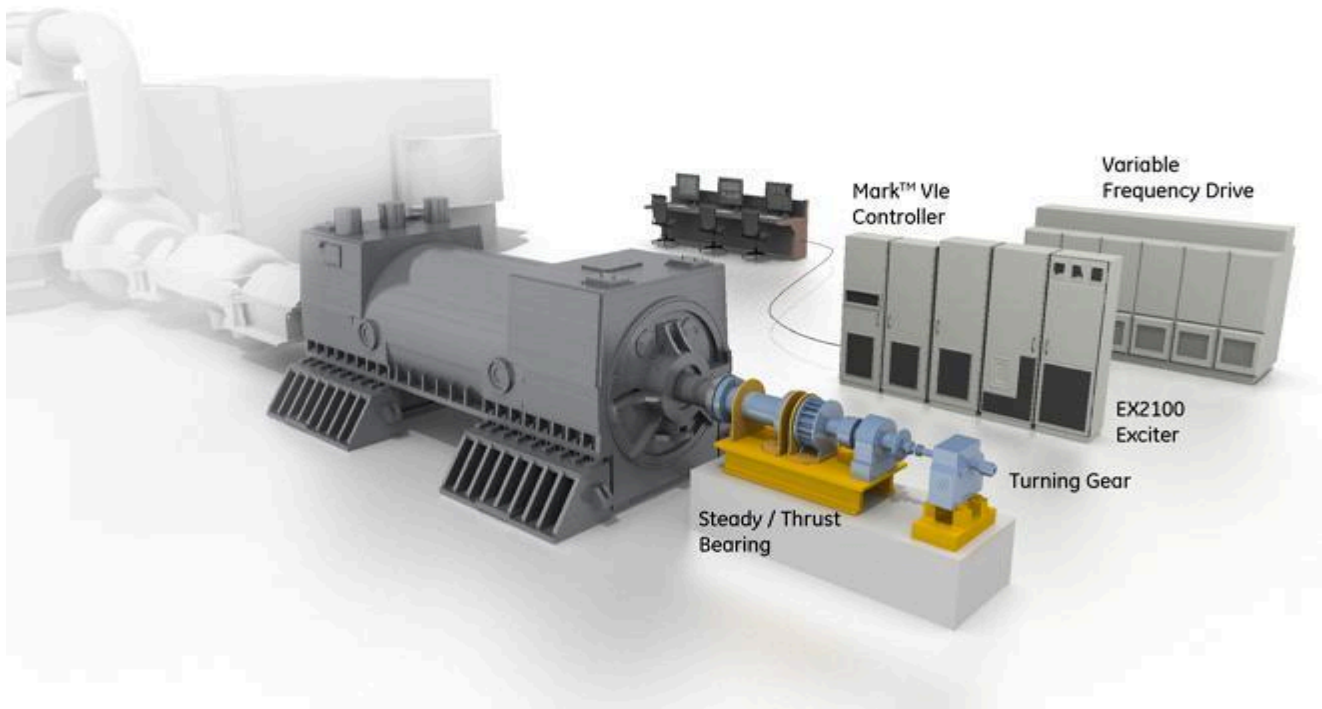

Figure7.4: Automatic power factor correction unit

Automatic power factor correction unit consists of a number of capacitors that are switched by means of contactors; these contactors are controlled by a regulator that measures power factor in an electrical network.

Depending on the load and power factor of the network, the power factor controller will switch the necessary blocks of capacitors in steps to make sure the power factor stays above a selected value.

Instead of using a set of switched capacitors, an unloaded synchronous motor can supply reactive power. The reactive power drawn by the synchronous motor is a function of its field excitation; this is referred to as a *synchronous condenser*. It is started and connected to the electrical network. It operates at a leading power factor and puts VARs onto the network as required to support a system's voltage or to maintain the system power factor at a specified level.

The condenser's installation and operation are identical to large electric motors. Its principal advantage is the ease with which the amount of correction can be adjusted; it behaves like an electrically variable capacitor.

Unlike capacitors, the amount of reactive power supplied is proportional to voltage, not the square of voltage; this improves voltage stability on large networks. Synchronous

condensers are often used in connection with high-voltage direct-current transmission projects or in large industrial plants such as steel mills. For power factor correction of high-voltage power systems or large, fluctuating industrial loads, power electronic devices such as the Static VAR compensator or STATCOM are increasingly used.

These systems are able to compensate sudden changes of power factor much more rapidly than contactor-switched capacitor banks, and being solid-state require less maintenance than synchronous condensers.

✓ 7.5 STATIC SYNCHRONOUS COMPENSATOR (STATCOM):

The Static Synchronous Compensator (STATCOM) is a shunt device of the Flexible AC Transmission Systems (FACTS) family using power electronics to control power flow and improve transient stability on power grids. The STATCOM regulates voltage at its terminal by controlling the amount of reactive power injected into or absorbed from the power system. When system voltage is low, the STATCOM generates reactive power (STATCOM capacitive). When system voltage is high, it absorbs reactive power (STATCOM inductive). Similarly to the SVC the STATCOM can provide instantaneous and continuously variable reactive power in response to grid voltage transients enhancing the grid voltage stability. Installing a STATCOM at one or more suitable points in the network will increase the grid transfer capability through enhanced voltage stability, while maintaining a smooth voltage profile under different network conditions. The STATCOM provides additional versatility in terms of power quality improvement capabilities.

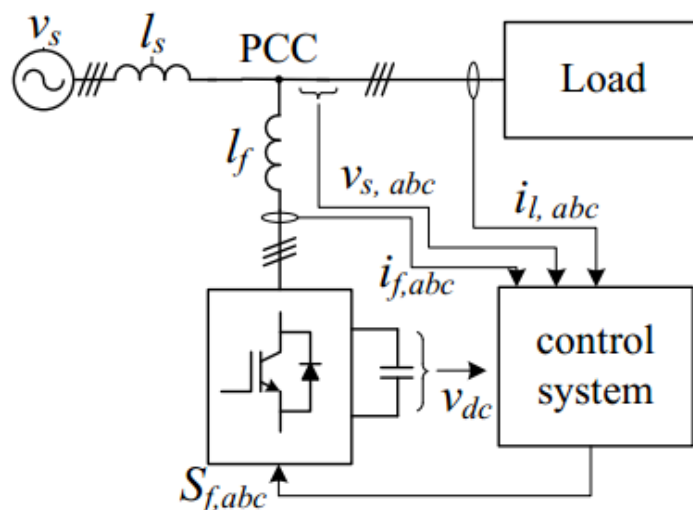

Figure 7.5: STATCOM installation

DETERMINING CAPACITANCE VALUE?

Power Factor₁=74%

Actual Power=594 KW

Interested to boost up=97%, Power Factor₂=97%

Power Factor=KW/KVA

$$\cos\theta = kW / kVA$$

$$\theta = \cos^{-1} (\text{PF1})$$

$$\theta = \cos^{-1} (74\%) = 42.27^\circ$$

The reactive power was about:

$$\tan\theta = Kvar / kW$$

$$Kvar = kW \times \tan\theta$$

$$Kvar = 594 \text{ kW} \times \tan (42.27) = 540 \text{ Kvar}$$

If the power factor were increased to 97%, the reactive power would be about:

$$\cos\theta = kW / kVA$$

$$\theta = \cos^{-1} (\text{PF2})$$

$$\theta = \cos^{-1} (97\%) = 14.07^\circ$$

$$Kvar = kW \times \tan\theta$$

$$Kvar = 594 \text{ kW} \times \tan (14.07) = 149 \text{ Kvar}$$

The reactive power was about:

$$\tan\theta = Kvar / kW$$

$$Kvar = kW \times \tan\theta$$

$$Kvar = 594 \text{ kW} \times \tan (42.27) = 540 \text{ Kvar}$$

If the power factor were increased to 97%, the reactive power would be about:

$$\cos\theta = kW / kVA$$

$$\theta = \cos^{-1} (\text{PF2})$$

$$\theta = \cos^{-1} (97\%) = 14.07^\circ$$

$$Kvar = kW \times \tan\theta$$

$$Kvar = 594 \text{ kW} \times \tan (14.07) = 149 \text{ Kvar}$$

Thus, the amount of capacitance required to boost power factor

From 74% to 97%:

$$540 \text{ Kvar} - 149 \text{ Kvar} = 391 \text{ Kvar}$$

✓ So we recommended 400kvar

✓7.6 Modulated power filter capacitor compensator

Power Factor correction on site with Pole C ³⁴ or: By adding Pole Capacitor to the system, the power factor is improved and the KW capacity of the system is increased. For example, a 1,000 KVA transformer with a 70% power factor provides 700 KW of power to the main bus. With the installation of capacitors so that the power factor is improved, say,

to 90%, the KW capacity of the system is increased to 900 KW. When a system power factor is improved, the amount of reactive current flowing

Is lowered thus reducing transformer and distribution circuit loads, and releasing system capacity.



Figure 7.6: Pole Capacitor

✓ 8. ADVANTAGES OF POWER FACTOR CORRECTION

– Eliminate Power Factor Penalties

- Increase System Capacity
- Reduce Line Losses in distribution systems
- Conserve Energy
- Improve voltage stability
- Increase equipment life
- Save on utility cost
- Enhance equipment operation by improving voltage
- Improve energy efficiency
- Reduction in size of transformers, cables and switchgear in new installations.
- Delay costly upgrades.
- Less total plant KVA for the same KW working power.
- Improved voltage regulation due to reduced line voltage drop.

9. DISADVANTAGES OF LOW POWER FACTOR

- Increases heating losses in the transformers and distribution equipments.
- Reduce plant life.
- Unstabilise voltage levels.
- Increase power losses.
- Decrease energy efficiency.
- Increase electricity costs by paying power factor surcharges.

10. Case Study: Brick Manufacturer

ITEMS	INITIAL PF	OPTOMIZED PF	INITIAL AMPS	OPTOMIZED AMPS	ESTIMATED KW SAVINGS	ESTIMATED SAVINGS PER MONTH
MIXER	75 %	94 %	58	46	1446.61	165.06 JD
BLOCK MACHINE	80 %	96 %	93	75	2474.2	382.31 JD
DUST COLLECTOR	76 %	99 %	32.5	25	1026.76	35.61 JD
COMPRESSOR	55 %	98 %	56	23	1280.33	146.09 JD
HOPPER#1	40 %	96 %	3.2	1.5	8.51	14.97 JD
HOPPER#2	40 %	96 %	3.2	1.5	8.51	14.97 JD
HOPPER#3	40 %	96 %	3.2	1.5	8.51	14.97 JD
CONVEYOR	45 %	94 %	8.5	4.5	38.16	4.35 JD
TOTAL					6291.6	778.9 JD

Cost reduction for factory machines

Harmonics Reduction

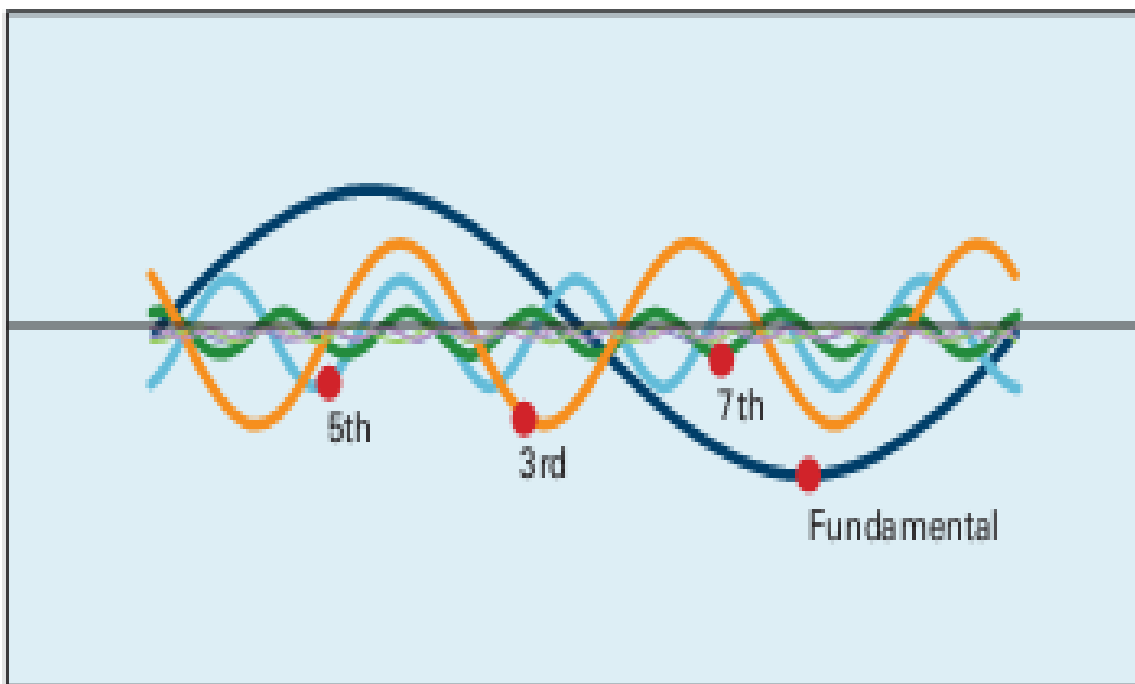

11. Power System Harmonics

- **Harmonic:** a mathematical definition, generally used when talking about Integral orders of Fundamental frequencies
- **Power system harmonics:** currents or voltages with frequencies that are integer multiples ($h=0,1,2,\dots,N$) of the fundamental power frequency

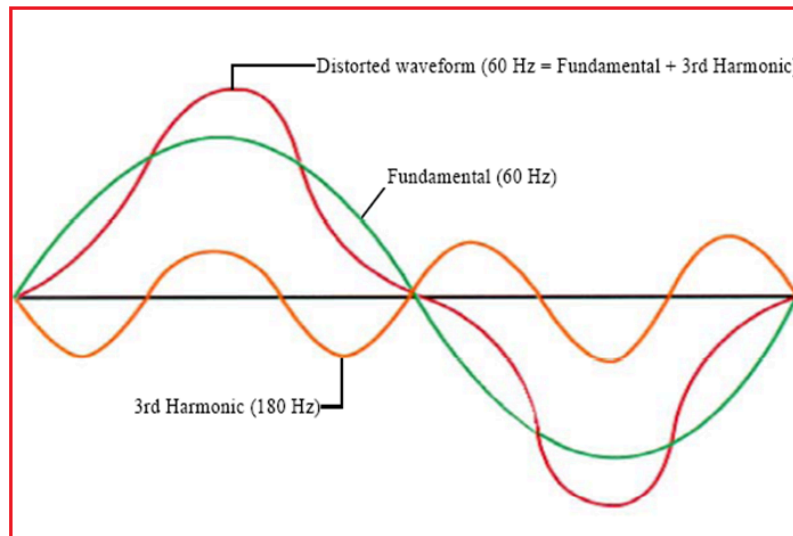

Figure 11: Harmonics wave form

1 st harmonic: 60Hz	—————>	Fundamental
2 nd harmonic: 120Hz	—————>	Integer multiple
3 rd harmonic: 180Hz	—————>	Integer multiple

11.1 What Causes Harmonics?

The main cause of harmonic is Non-Linear Loads

- Current is not proportional to the applied voltage, The distortion comes from a Nonlinearity caused by saturation, electronic-switching and nonlinear electric loads, Inrush/Temporal/Arc/Converter/Limiter/Threshold Type Loads.

Linear loads and current waveforms:

Pure resistance, inductance, and capacitance are all linear.

What that means:

If a sine wave voltage of a certain magnitude is placed across a circuit containing pure resistance, the current in the circuit follows

Ohm's Law: $I = E \div R$.

So, for a specific value of ohms, the relationship of volts and amperes is a straight line. The current will always be a sine wave of the same frequency.

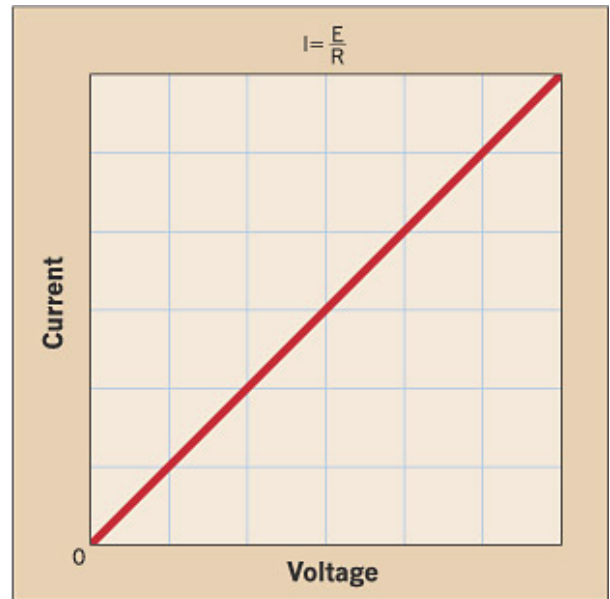

Figure 11.1 A: Linear Load

Linear Loads include Incandescent lighting, heating loads, and motors.

Nonlinear loads and current waveforms:

Solid state electronics is based on the use of semiconductors. These materials are totally different in that their response to voltage is not a straight line.

What this means:

With a nonlinear load, you cannot easily predict the relationship between voltage and current — unless you have an exact curve for each device. With equipment containing many solid-state devices, such an approach is impossible.

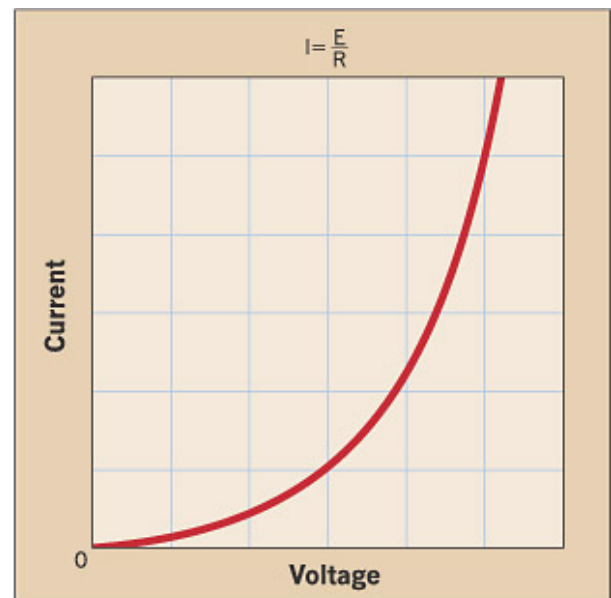

Figure 11.1 B: Non Linear Load

Nonlinear loads are switched on for only part of the cycle, as in a thyristor-controlled circuit, or pulsed, as in a controlled-rectifier circuit.

-Power system harmonics presenting deviations from a perfect sinusoidal-waveform.

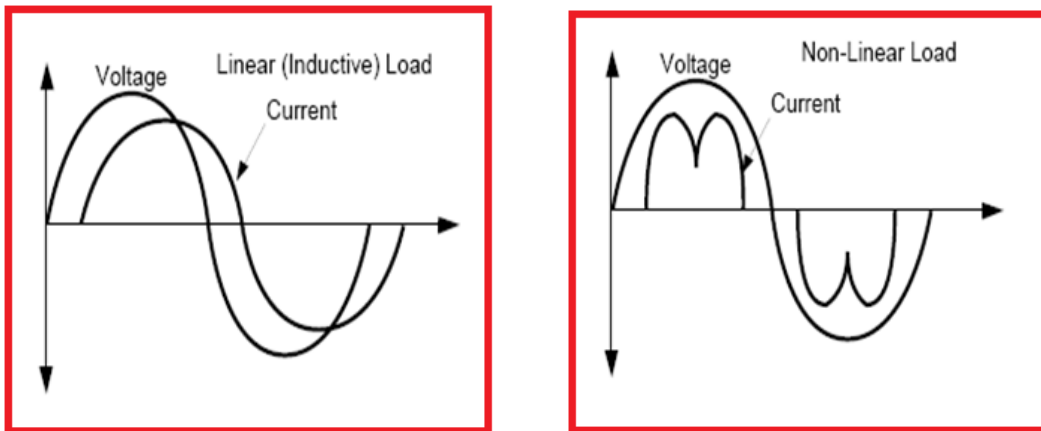

Figure 11.1 C: Linear Load vs. nonlinear load wave form

11.2. Effect of harmonics on waveform

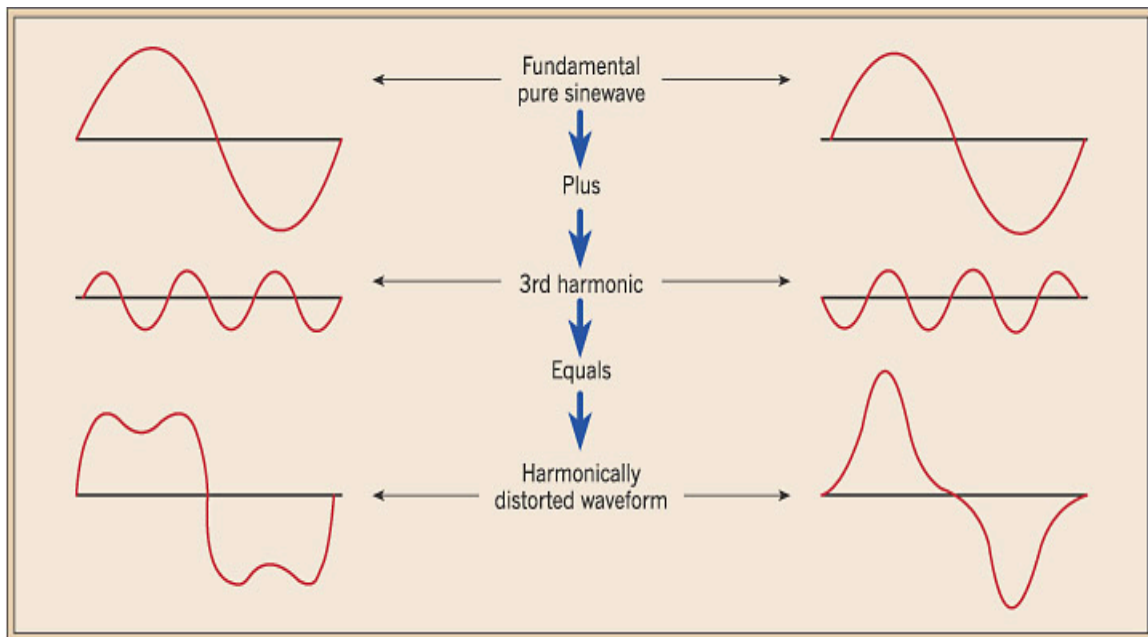

Figure 11.2: Harmonically distorted wave

When a waveform is identical from one waveform to the next, it can be represented as a sum of pure sine waves in which the frequency of each sinusoid is an integer multiple of the fundamental frequency of the distorted wave.

12. What do harmonics do?

- Harmonics are carried through the system from the source and can nearly **double** the amount of current on the neutral conductor in three phase four wire distribution systems.
- Distorted currents from harmonic-producing loads also distort the voltage as they pass through the system impedance. Therefore, a distorted voltage can be presented to other end users on the system.
- Overall electrical system and power quality is affected by the introduction of harmonics.

12.1. Recall the Fourier series

$$f(t) = a_0 + (a_1 \cos t + b_1 \sin t) + (a_2 \cos 2t + b_2 \sin 2t) + (a_3 \cos 3t + b_3 \sin 3t) + \dots$$

The term $(a_1 \cos t + b_1 \sin t)$ is known as the **fundamental**.

The term $(a_2 \cos 2t + b_2 \sin 2t)$ is called:

"The **second harmonic**

The term $(a_3 \cos 3t + b_3 \sin 3t)$ is called:

The **third harmonic**, etc

● Odd Harmonics

The Fourier series will contain **odd harmonics** if $f(t + \pi) = -f(t)$.

In this case, the Fourier expansion will be of the form:

$$f(t) = a_0 + (a_1 \cos t + b_1 \sin t) + (a_3 \cos 3t + b_3 \sin 3t) + (a_5 \cos 5t + b_5 \sin 5t) + \dots$$

All of the harmonics are **odd**.

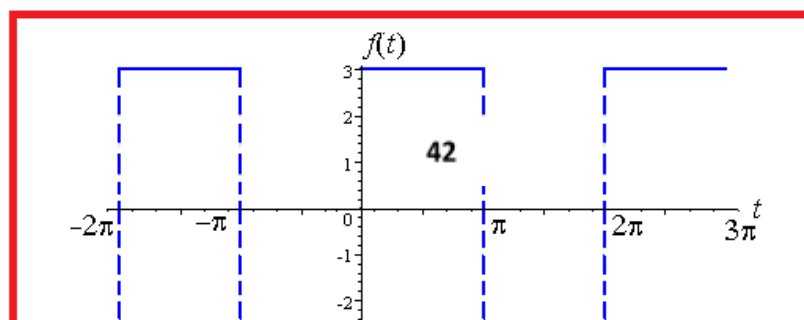

Figure 12.1 A: Odd Harmonics

- **Even Harmonics**

The Fourier series will contain even harmonics if $f(t+\pi) = f(t)$. That is, it has period π .

In this case, the Fourier expansion will be of the form:

$$f(t) = a_0 + (a_2 \cos 2t + b_2 \sin 2t) + (a_4 \cos 4t + b_4 \sin 4t) + (a_6 \cos 6t + b_6 \sin 6t) + \dots$$

All of the harmonics are **even**.

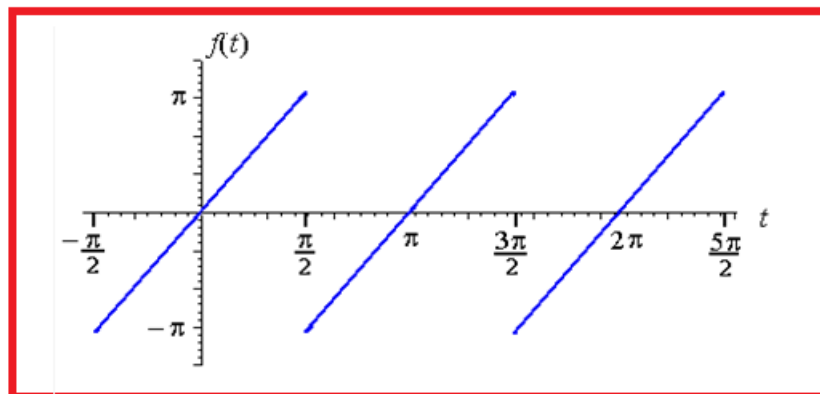

Figure 12.1 B: Even Harmonics

13. How to Quantify ⁴³ harmonic Distortion?

- **Total Harmonic Distortion-THD**: the contribution of all harmonic frequency Currents/Voltages to the fundamental current.
- The level of THD for Current or Voltage is directly related to the frequencies and amplitudes of the Offending Quasi-Steady State persistent Harmonics.
- Individual Distortion Factor (DF) quantifies Distortion at harmonic order.

13.1. Calculation of THD

THD: Ratio of the RMS of the harmonic content to the RMS of the Fundamental.

The THD is the means to express as a single number the distortion affecting a current or voltage flowing at a given point in the installation, it expressed as a percentage.

Current and voltage THD

- For current harmonics, the equation is:

$$THD_i = \sqrt{\left(\frac{I_{rms}}{I_1}\right)^2 - 1}$$

- For voltage harmonics, the equation is:

$$THD_v = \frac{\sqrt{\sum_{h=2}^{\infty} V_h^2}}{V_1}$$

V_h is rms value of the harmonic order h.

V_1 is the rms value of the fundamental component.

The *distortion power factor* describes how the harmonic distortion of a load current decreases the average power transferred to the load.

$$\text{distortion power factor} = \frac{1}{\sqrt{1 + \text{THD}_i^2}} = \frac{I_{1, \text{rms}}}{I_{\text{rms}}}$$

THD_i is the total harmonic distortion of the load current.

This definition assumes that the voltage stays undistorted (sinusoidal, without harmonics). This simplification is often a good approximation in practice.

$I_{1, \text{rms}}$ is the fundamental component of the current and I_{rms} is the total current - both are root mean square-values.

The result when multiplied with the displacement power factor (DPF) is the overall, true power factor or just power factor (PF):

$$\text{PF} = \text{DPF} \cdot \frac{I_1}{I_{\text{rms}}}$$

The Relation between THD and Power Factor:

$$\text{PF} = \frac{P}{S} = \frac{U_1 \cdot i_1 \cdot \cos\phi_1}{U_1 \cdot I_{\text{rms}}}$$

$$\frac{I_1}{I_{\text{rms}}} = \frac{1}{\sqrt{1 + \text{THD}_i^2}}$$

$$\text{PF} = \frac{\cos\phi_1}{\sqrt{1 + \text{THD}_i^2}}$$

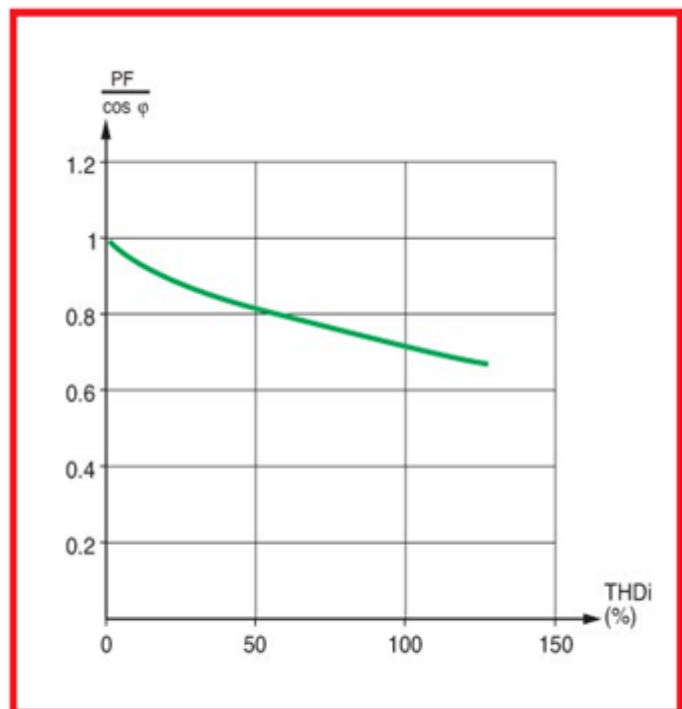

figure 13.1: graph of $\frac{\text{PF}}{\cos\phi}$ as a function of THDi.

14. Sources of Harmonics

Solid State Electronic Devices which contain a poor power supply

Computers (PCs/CPUs): (Video display terminals)

Laser Printers :(File Servers)

Copy Machines :(Battery Chargers)

Solid state UPS Units

Solid State Devices: (Fluorescent lighting ballasts)

Rectifiers: (AC-DC Converters □ VFDs)

Welding units

Arc furnaces

15. Effects of Harmonics

- **Distorted Voltage**
- **Overheated Transformers and Motors:**
 - Increases Hysteresis (magnetization) losses in steel and iron cores of transformers, motor and magnetic trip units of circuit breakers (Equipment inefficiencies and overheating)
- **Heating of Neutral Conductors:**
 - Skin Effect □ Increased amount of current flowing on the outside of conductors (overheating)
- **Low Voltage at End Loads**
- **High Neutral to Ground Voltages at End Loads.**
- **Operation Problems of Relays and Circuit Breakers:**
 - Thermal/Magnetic Trip Circuit Breakers:

Harmonic currents increase eddy current losses in the core steel of the metallic strip.

This causes an OVER protection situation... Increased losses generate additional heat, this effect the thermal trip of the unit.

– Electronic Trip Circuit Breakers

Magnitude and phase angle(s) of harmonic current(s) in relationship to the fundamental current can cause:

- Overprotection when: Peak current sensing > True RMS
- Under protection when: Peak current sensing < True RMS

Changing power system loads will vary the magnitude and phase angle, resulting in inaccurate and unpredictable sensing units and overload protection.

• Communication Problems

If sharing common parallel path, potential for harmonics to have inductive coupling effect on unshielded cabling.

• Current Measurement Problems (distorted waveform)

• Unreliable Operation of Electronic Equipment

(Mis-operation of electronic equipment that measures frequency)

• Control of Speed and Voltage Problems on Emergency Generators

(supplying power)

• Capacitor Bank Application Problems

(Heating)

• Computer (PC/CPU) data errors / data loss

(Affects power supplies and sensitive electronics)

16. How can Harmonics be reduced?

✓ 16.1. Harmonic mitigating transformers



Figure 16.1: mitigating transformers

HMTs are an economical solution against the harmful effects of harmonics. HMTs are highly reliable passive devices; they don't have any moving parts and they are typically energized 24 hours a day, seven days a week. This means that they are always "on the job" treating harmonics, regardless of the level of load they are serving at a given point in time. Whenever the HMT is energized, it will provide harmonic treatment.

Harmonic mitigating transformers are commonly referred to as "phase-shifting" transformers.

The HMT has three-wire connected primary windings and four-wire connected secondary windings. The fundamental changes to the magnetic of the transformer winding allow a transformer to be designed in a wide variety of different phase-shifts (-15° , 0° , $+15^\circ$, 30°).

In standard delta-wye transformers, including K-factor rated transformers, triplen harmonics are passed from the secondary windings, into the primary delta windings, where they flow and cause substantial additional watt loss. In HMTs, the electro-magnetic flux cancellation created by the zigzag winding configuration prevents 3rd and other triplen harmonics from being transmitted into the primary delta winding. Harmonic treatment is provided entirely by electromagnetic flux cancellation; no filters, capacitors, or other such devices are used.

It is important to remember that the harmonic currents still flow to the secondary windings.

✓ 16.2. Phase shifting (zig-zag) transformers:



Figure 16.2 A: Phase shifting (zig-zag) transformer

A zigzag transformer is a special purpose transformer with a zigzag or "interconnected star" winding connection used to cancel out specific harmonics by making one voltage circuit 180 degrees out-of-phase

The most common zigzag transformer application is for the derivation of a neutral connection from an ungrounded 3-phase system and the grounding of that neutral to an earth reference point. Zigzag transformers are also used to control triplen (3rd, 9th, 15th, 21st, etc.) harmonic currents, to supply 3-phase power as an autotransformer (serving as the primary and secondary with no isolated circuits), and to supply non-standard phase-shifted 3-phase power.

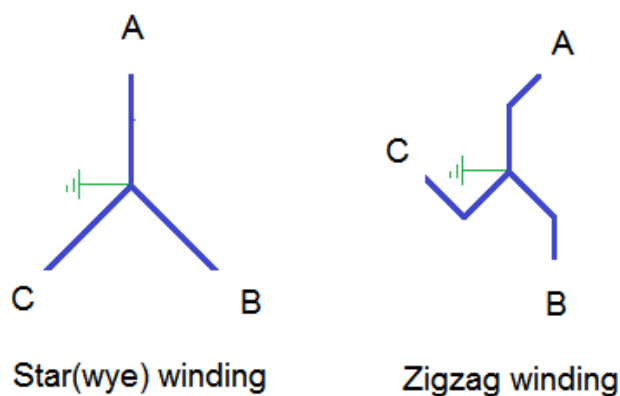

Figure 16.2 B: zig-zag winding

For example, an electrical network may have a transmission network of 110 kV/33 kV star/star transformers, with 33 kV/11 kV delta/star for the high voltage distribution network. If a transformation is required directly between the 110 kV/11 kV network the most obvious option is to use 110 kV/11 kV star/delta. The problem is that the 11 kV delta no longer has an earth reference point. Installing a zigzag transformer near the secondary side of the 110 kV/11 kV transformer provides the required earth reference point.

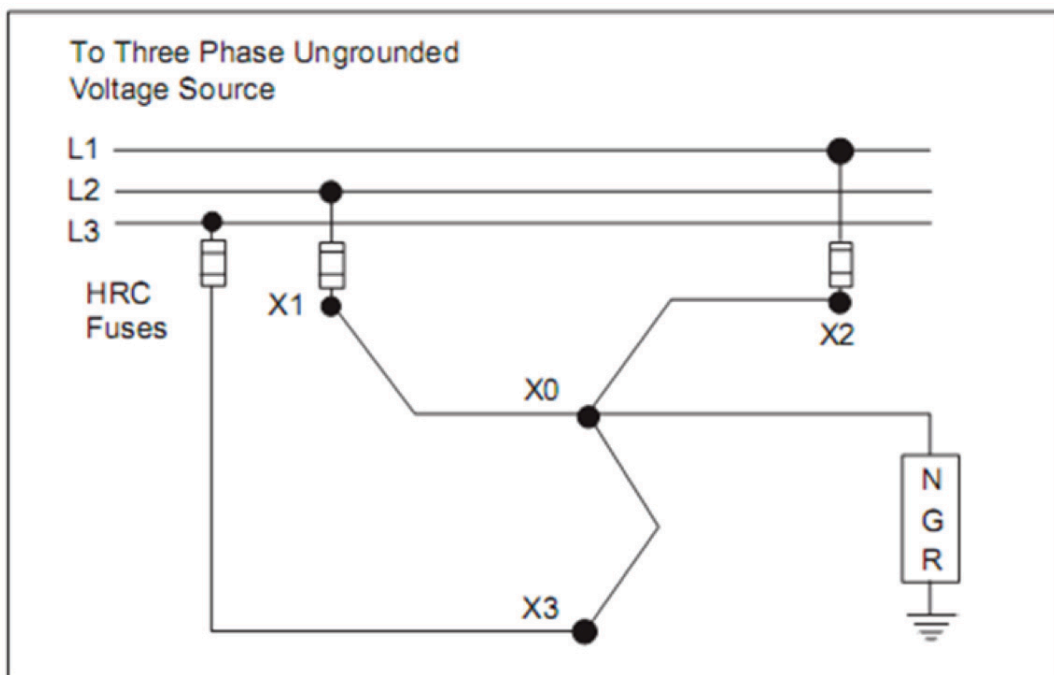

Figure 16.2 C: zig-zag transformer installation

✓ 16.3. Harmonic Filter Banks:



Figure 16.3 A: Harmonic Filter Banks

Voltage Harmonic Filter Banks reduce harmonic distortion and improve power factor, increasing system performance and resulting in significant cost savings. Consisting of capacitors, reactors and sometimes resistors, harmonic filter banks provide a low impedance route out of the system for harmonics. The series capacitor/reactor combination prevents resonance by tuning the network below the first dominant harmonic (usually the 5th or 300Hz). Since three phase networks typically have little or no harmonic current below the fifth, there is no energy available to resonate. Distortion is reduced to the required levels. The metal-enclosed design provides maximum environment protection and safety, while maintaining a compact installation footprint.

Installation of filter banks will protect a plant's distribution system and equipment, as well as the utility's distribution system. Reduced harmonic distortion will improve a plant's productivity by preventing the following problems:

1. Motor inefficiency.
2. Blown capacitor fuses.
3. False operation of breakers and fuses.
4. Abnormal heating of equipment (e.g., transformers, switchgear).
5. Excessive copper losses within transformers.
6. Worn conductor insulation.
7. Measurement errors by utility meters.

8. Neutral bus bar and lugs overloading.

9. Phone line interference.

10. Noise.

11. Problematic operation of drives and power supplies.

51

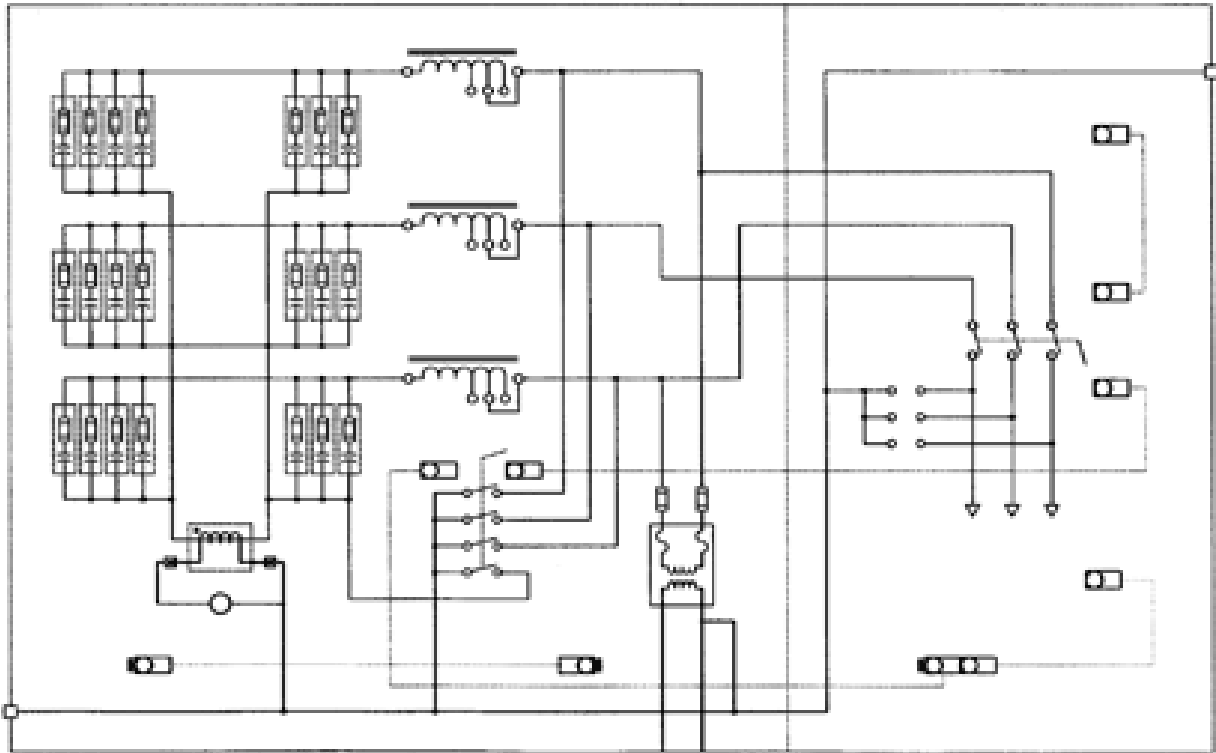

Figure 16.3 B: Harmonic Filter Banks installation

✓ 16.4. For VFD and UPS specifically:

- Line Reactors
- K-Rated / Drive Isolation Transformers.
- Harmonic Mitigating / Phase Shifting Transformers.
- 12, 18 or 24 pulse Converters.
- Passive parallel / series tuned Filters.
- Active Filters.

✓ 16.5. PROPER GROUNDING

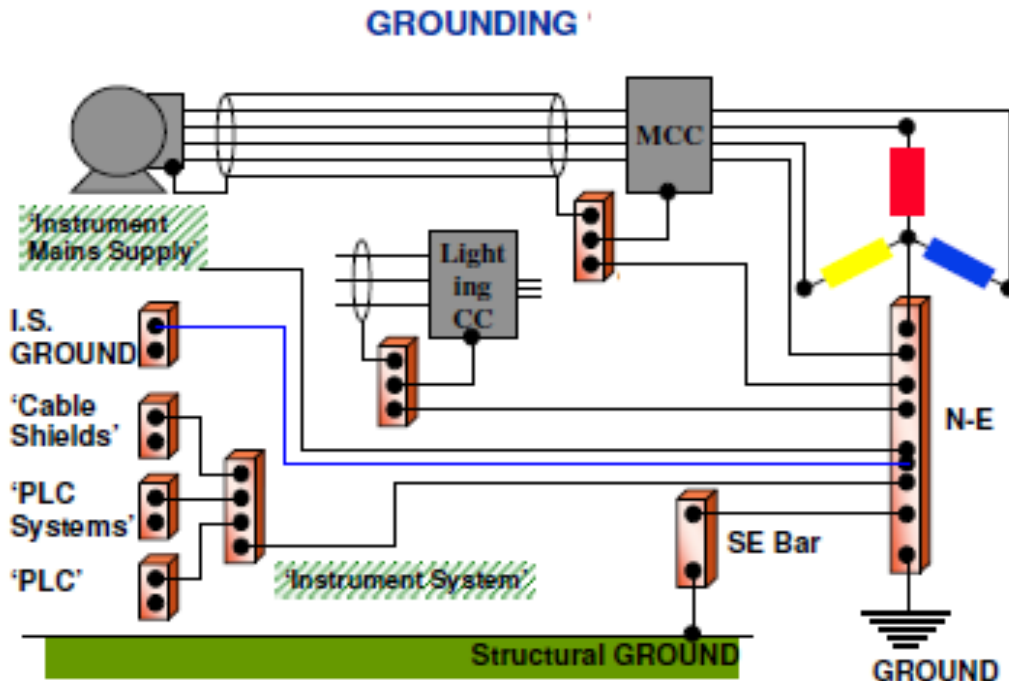

Figure 16.5: proper grounding

- Neutral to ground conductor connection at one location; at main panel or transformer secondary
- When neutral is connected to ground at multiple locations, interference can occur with sensitive electronic devices.
- Run power and control conductors in separate raceways
- Sensitive loads should not share neutral and ground conductors.
- Avoid using conduit as the ground return path, run dedicated ground wire with circuit conductors.

✓ 16.6. Isolate harmonic loads on separate circuits:

- ✓ With or without harmonic filters

17. Harmonics Evaluation Procedure

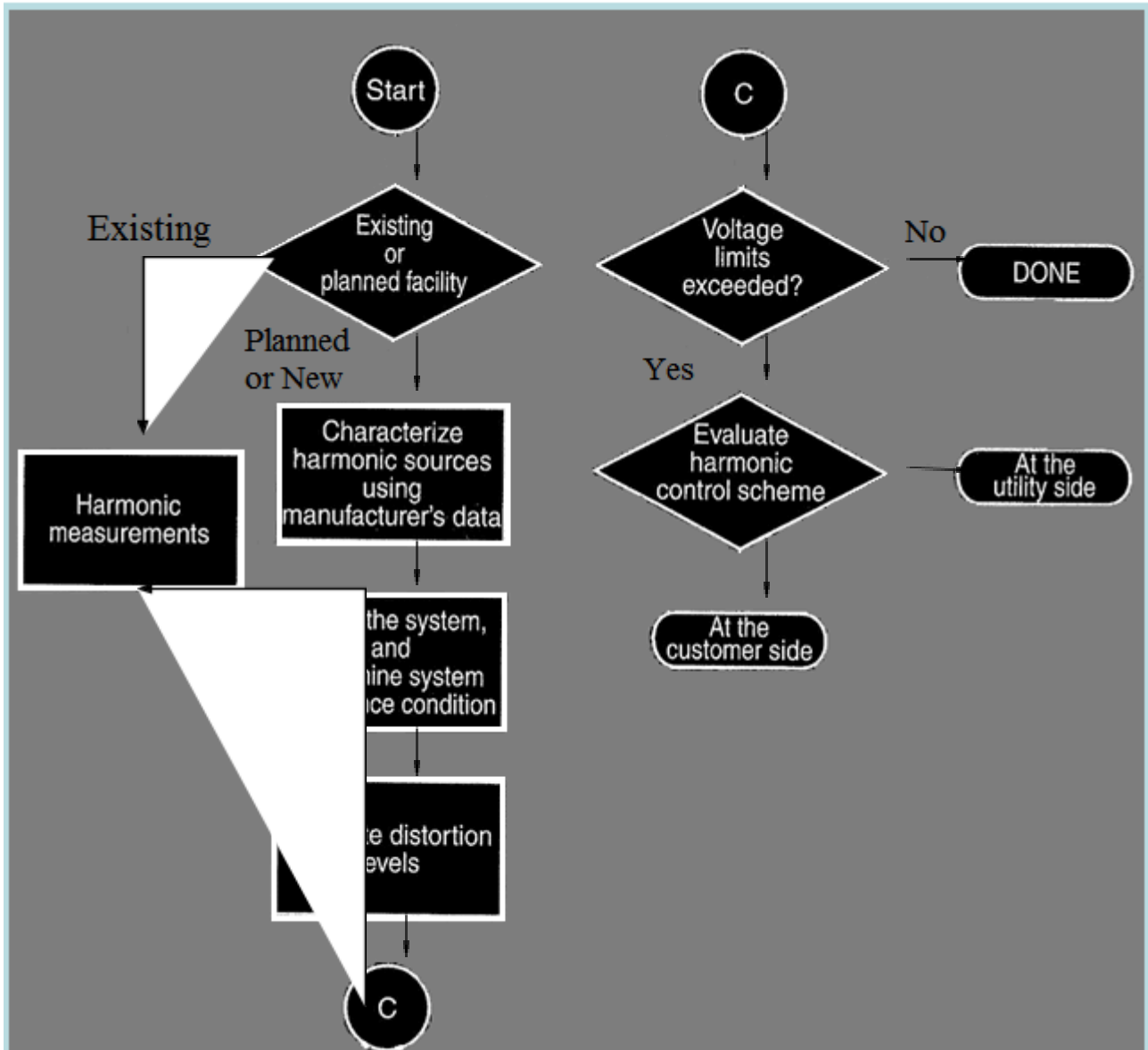
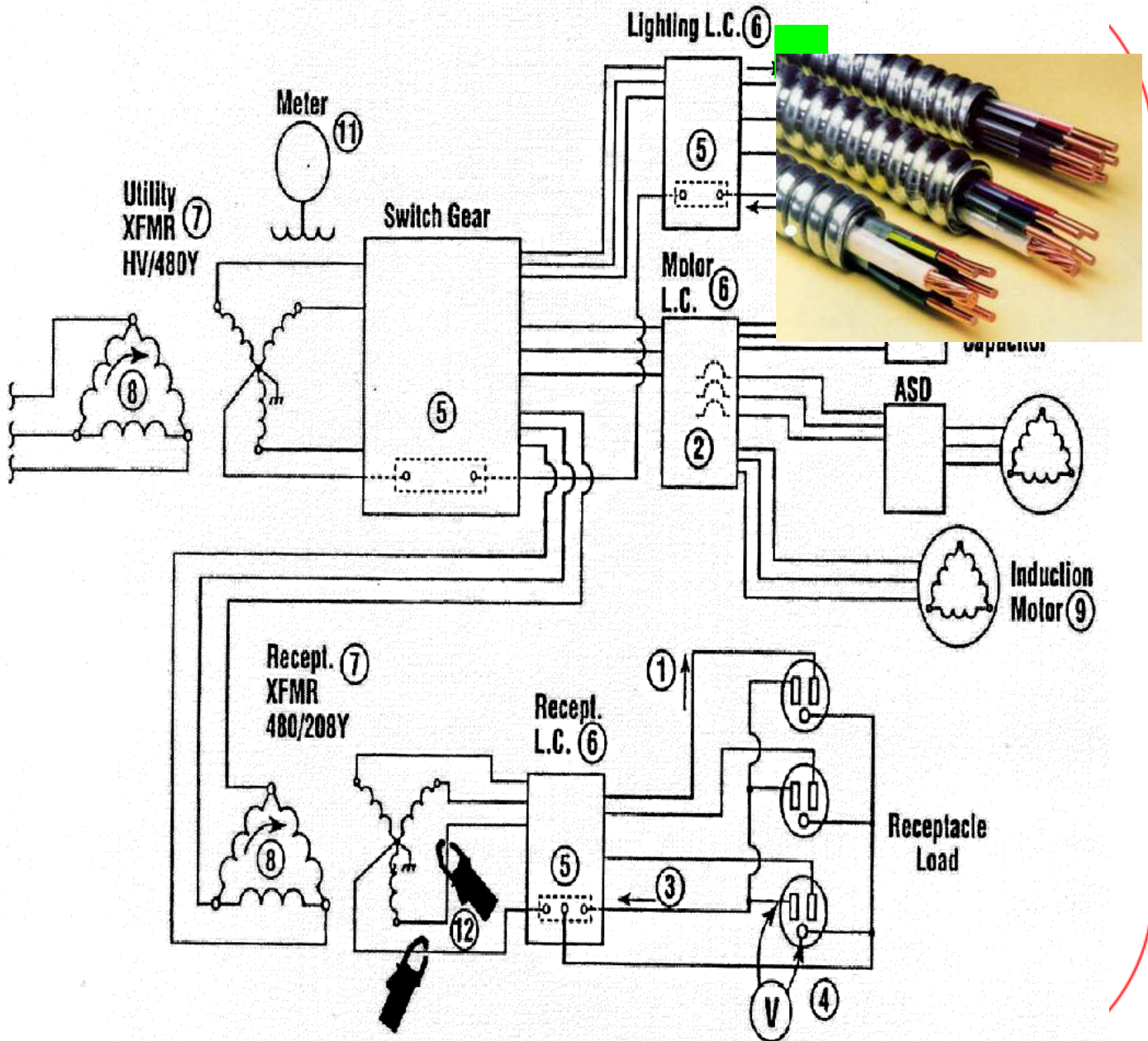

Figure 17: Harmonics Evaluation Procedure

18. Simplified Distribution System Diagram



Phase Conductors: Heating from Skin Effect.

Conduits: Heating from Skin Effect and eddy currents.

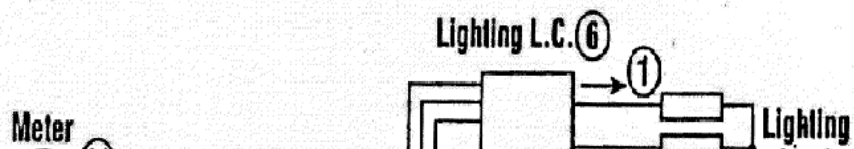

Circuit breakers: False tripping due to high heat and high frequencies caused by harmonics.

-Peak sensing CB's may trip because of higher peaks.



56

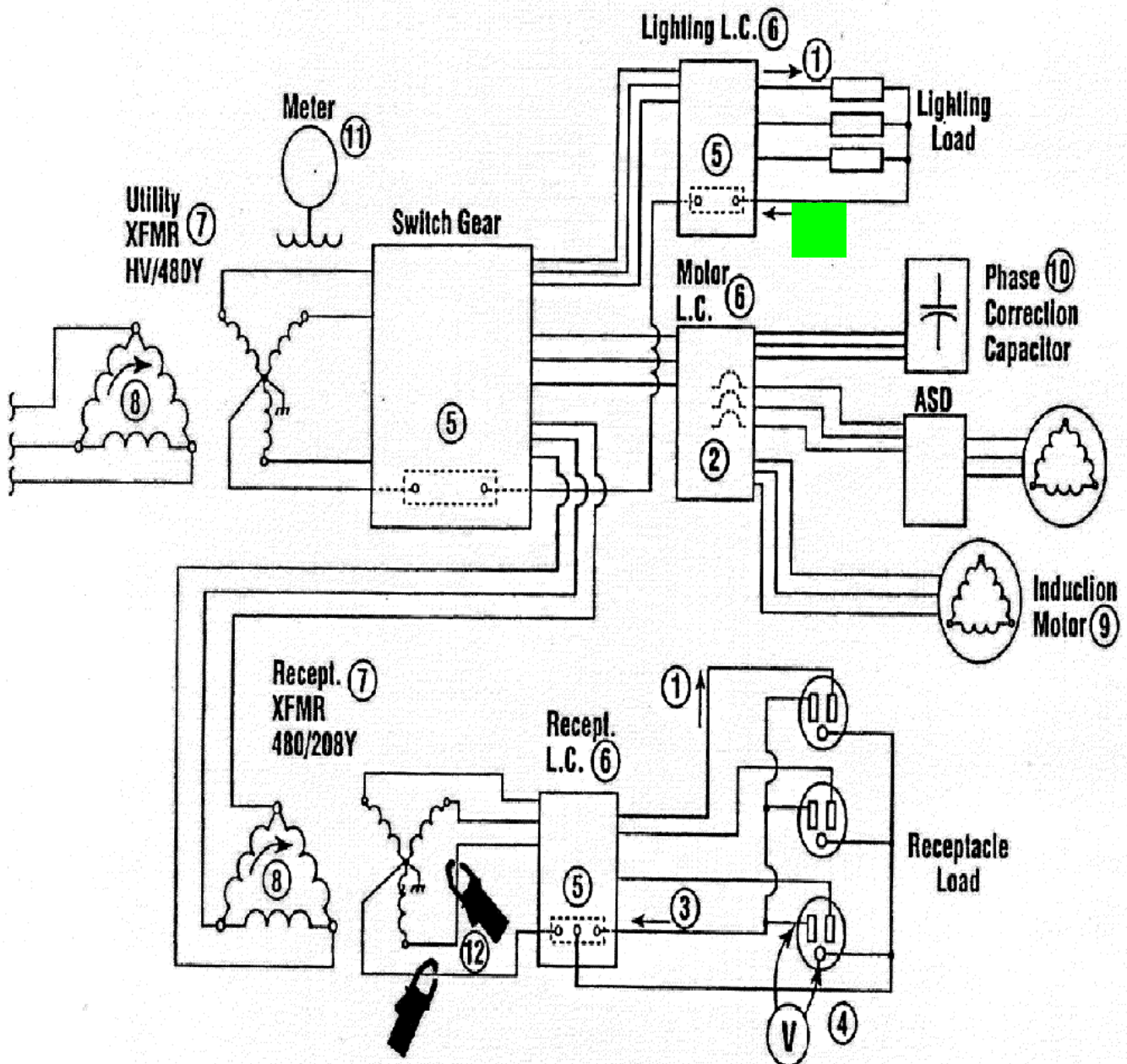

Neutral conductors: high current from zero sequence tripled harmonics (3rd & 9th) can add as much as 30% to neutral current even if phases are balanced. Shared neutrals or reduced size neutral can be hazardous (no CB to protect from over current!)

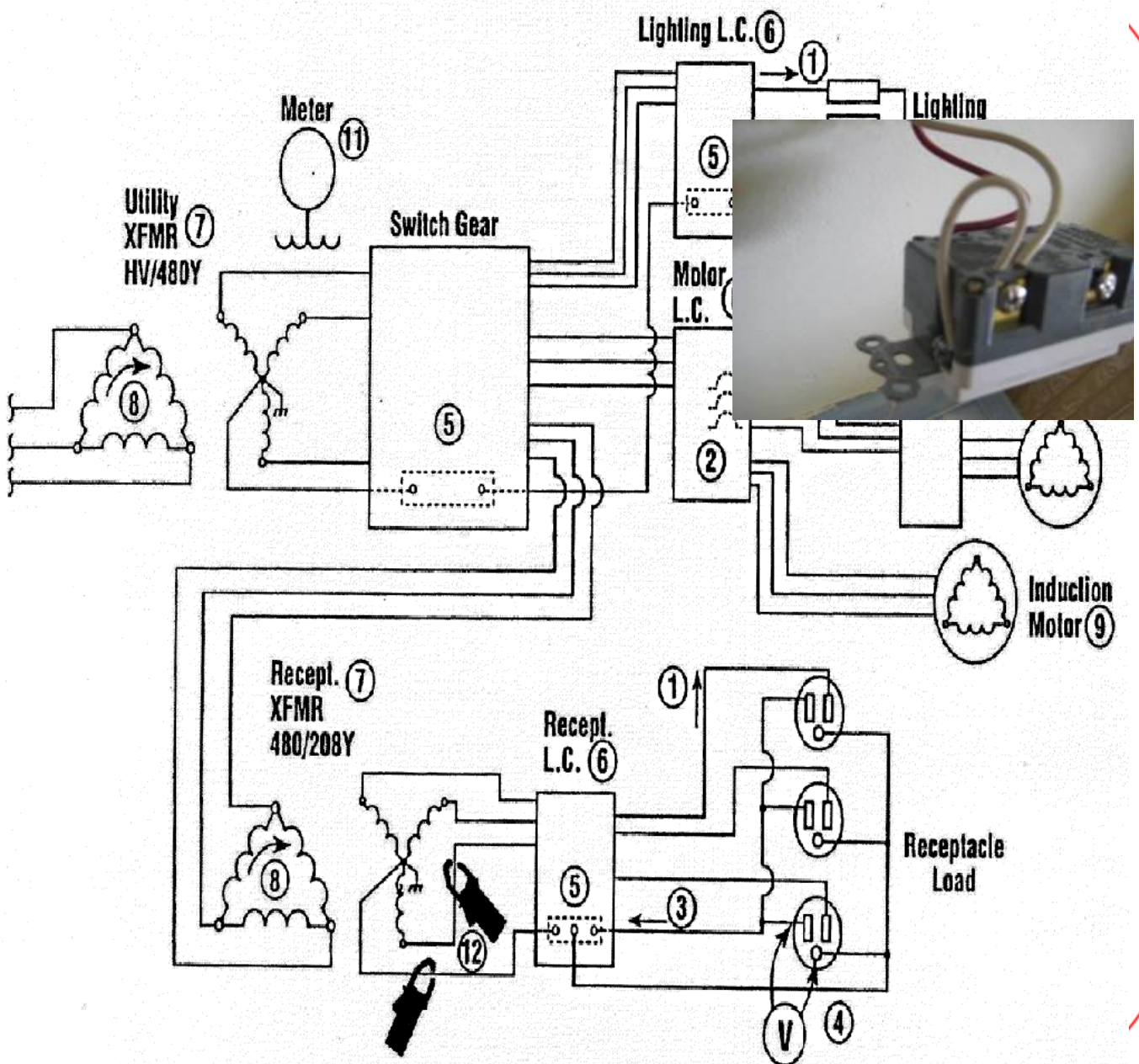
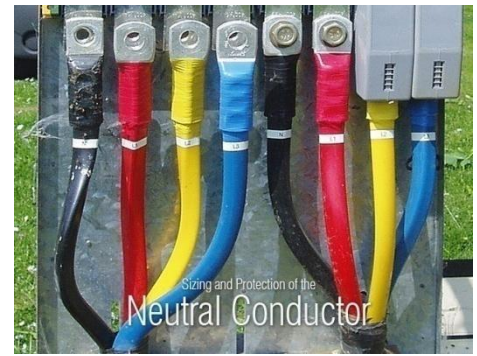

Neutral to ground voltage at receptacle: Excessive neutral current results in high voltage drops between neutral and ground at the outlet.

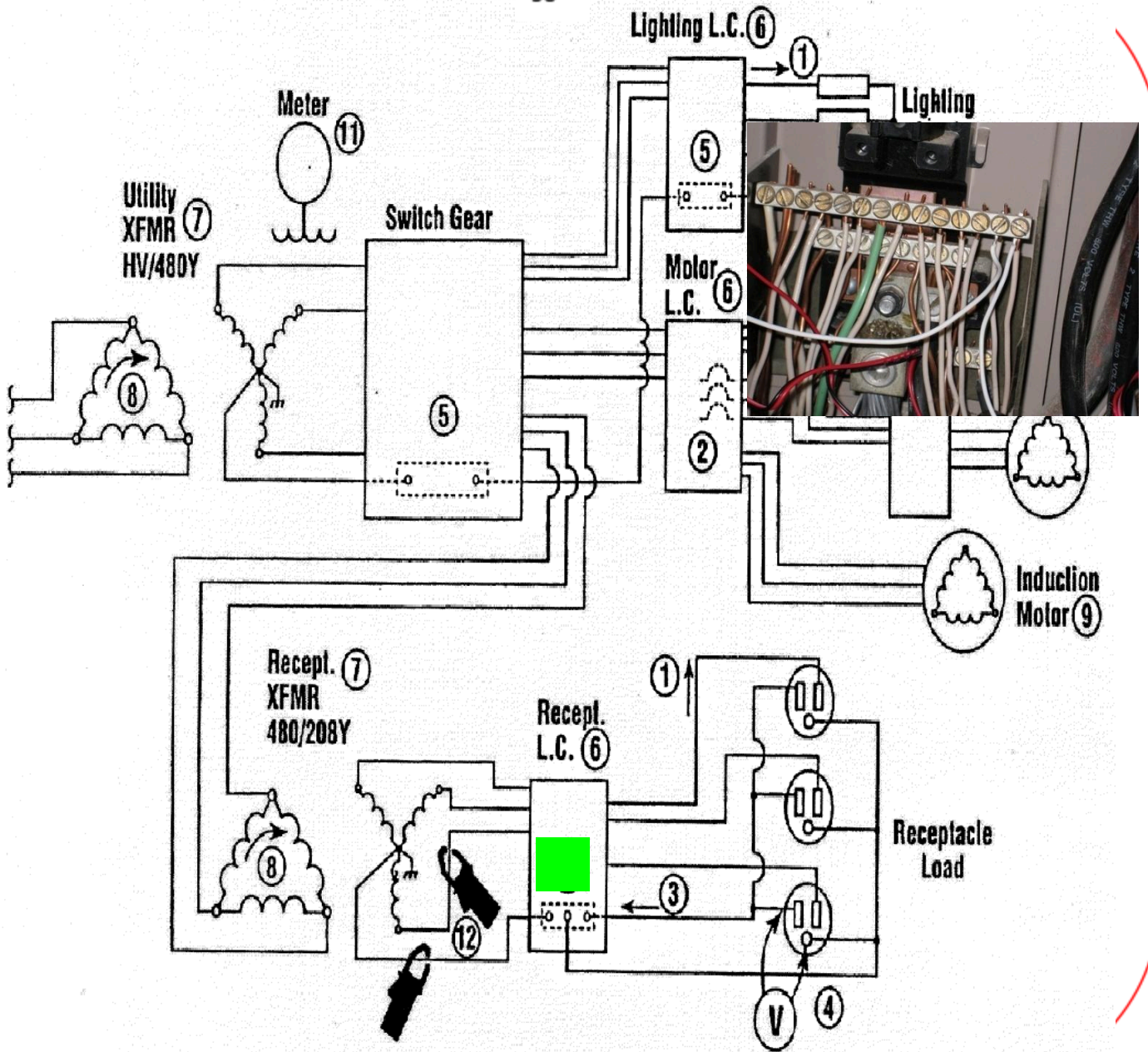

Neutral bus bar: overloading and heat from zero sequence harmonics (3rd and 9th).

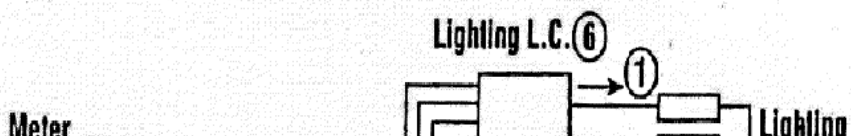

Panel board enclosure: heating from eddy currents (induced currents caused by magnetic fluxes), as well as vibration ("buzzing" sound).



60

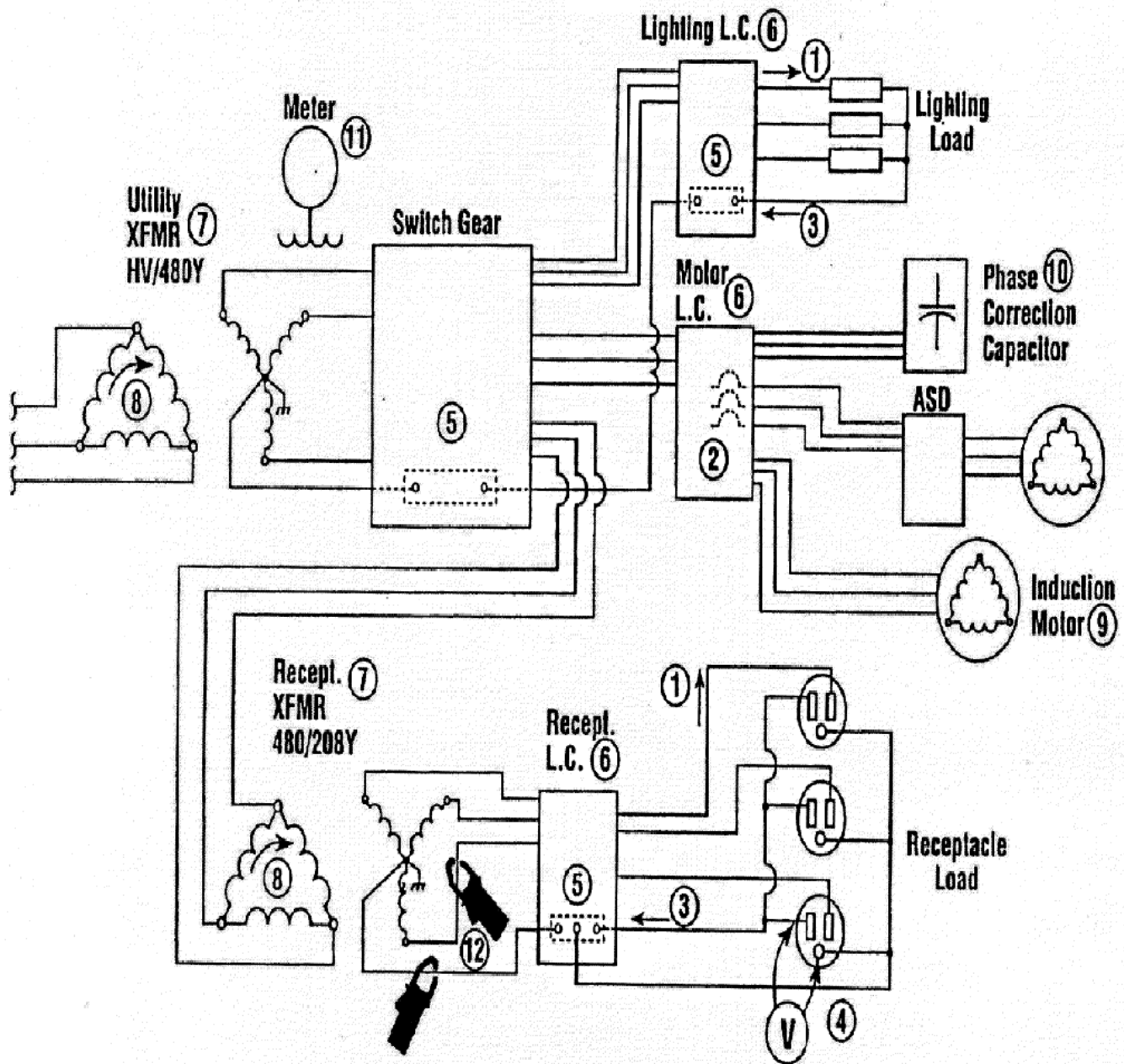

Transformers: heating from eddy currents reduces the life of a transformer insulation system, and lowers efficiency.

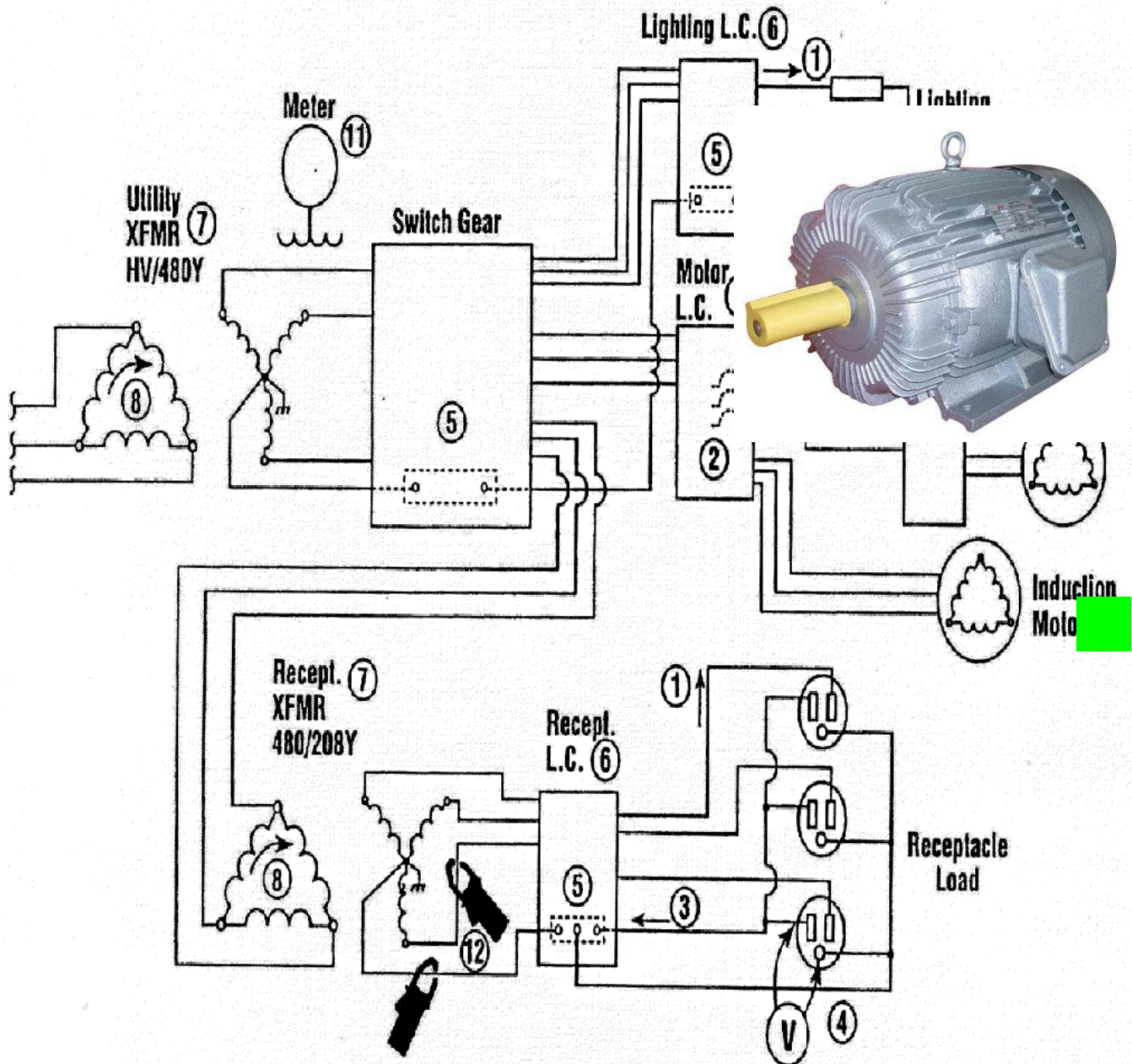

Induction Motor Leads: Heating from eddy currents and negative sequence harmonics (5th, 11th, 17th, etc.)

Note: Negative sequence harmonics work AGAINST a motor's natural rotation, making it work harder!

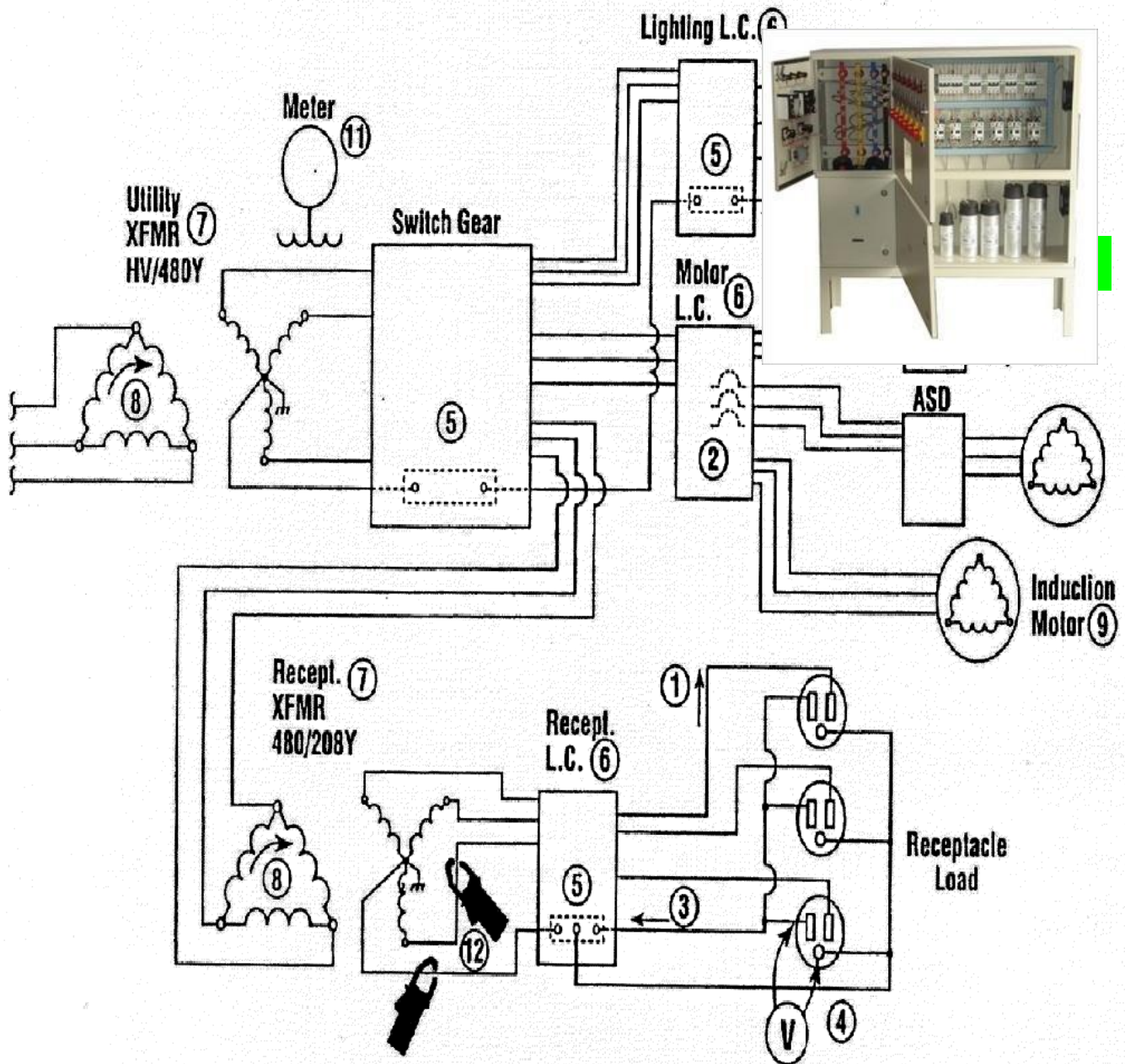

Power factor (Kvar) Capacitors: since they are lowest impedance, resultant high harmonic current can overheat capacitors and/or blow fuses.

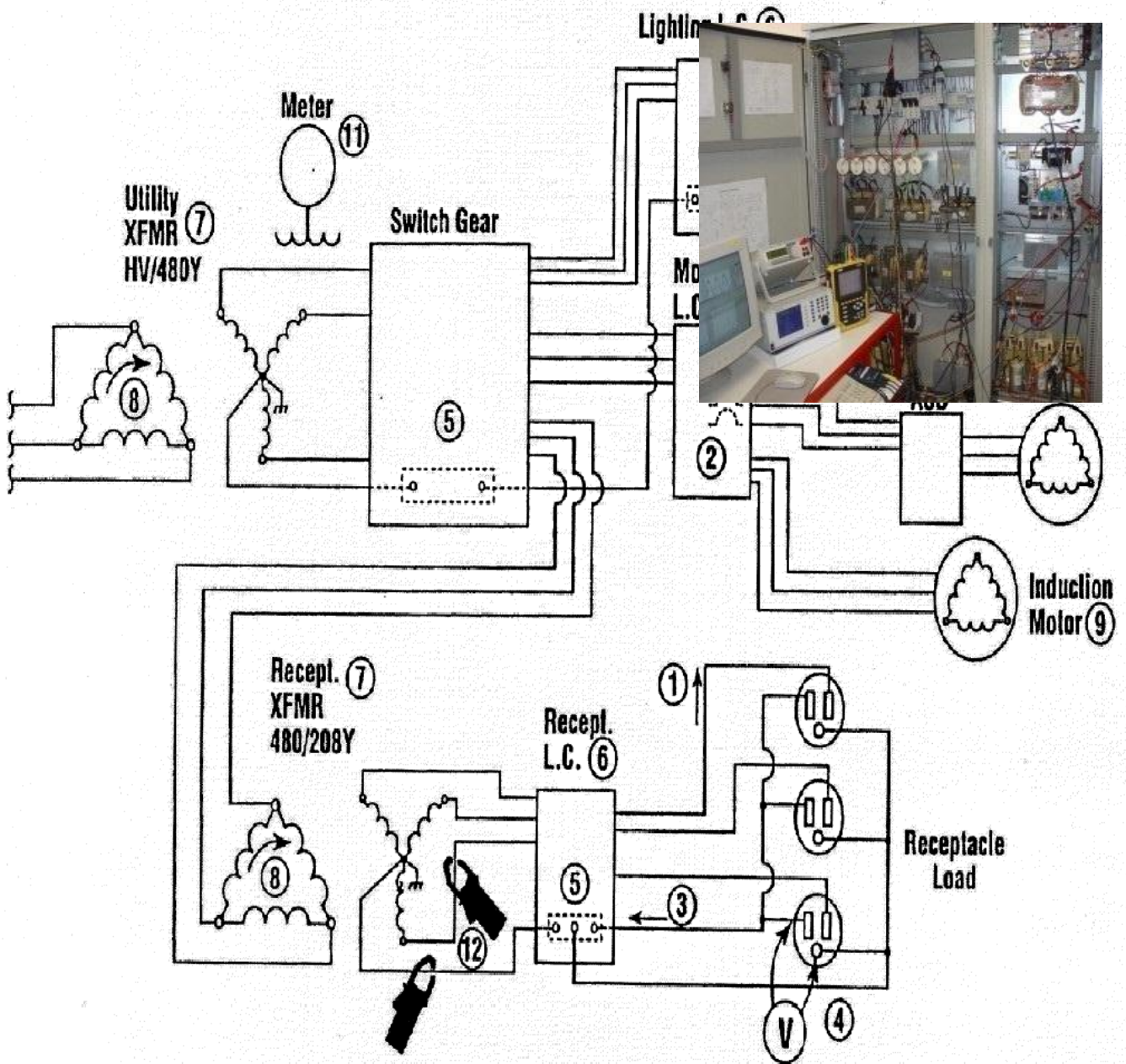

KW and Kvar meter: may have reading errors when
 Harmonic currents are present.

19. Energy optimization by KVAR KEC

64
 (Kvar Energy Controller)

By implementing KEC technology at individual inductive loads, the KVARs required by the motor are provided by the KEC unit rather than the electrical system. Consequently, the power used from the electricity provider is mostly kW.



Figure 19: KEC

system from the inductive equipment (motors) back to the KVA electric meter, kilowatt hour meter (kWh) or

- THIS TIME TURNING SLOWS DOWN the operation of the meter, reduces the amount of power drawn from the utility and therefore saves on electricity consumption.

19.1. BENEFITS OF KEC

- ✓ Decreasing the amount of electricity needed for inductive loads operation.
- ✓ Improving power system capacity.
- ✓ protects from power line surges as well as spikes caused by internal wiring problems, loose connections and fluctuating demand
- ✓ Protects sensitive electronic devices.
- ✓ Reduces the harmful effects from electro-magnetic fields and in so-doing increases the life expectancy of motors and appliances.

- ✓ Useful for voltage regulation.
- ✓ Increasing power factor percentage.
- ✓ Decreasing heating and in so-doing increases the life expectancy of appliances.
- ✓ Save from 6% up to 25% on residential, commercial or industrial electric bill!

19.2. Principle of operation

KEC fine tunes the electrical system from the inductive equipment (motors) back through the utility company's KVA electric meter, kilowatt hour meter (kWh) or demand meter.

This fine tuning slows down the operation of the meter, reduces the amount of power drawn from the utility and therefore saves on electricity consumption. The KEC stores the reactive power to create the electromagnetic field (EMF) around the inductive windings of a motor by storing in its capacitors. As motors operate, reactive power is "pulled" and "pushed" to and from the KEC by the motor at 60 cycles /second.

The KEC stores and releases what the motors need to function more efficiently. This unique approach reduces the heat generated on the lines and therefore reduces the strain placed on all the electrical components so they actually will increase their life expectancy.

Electricity that is normally pushed back through the power distribution lines is now reclaimed and recycled by the KEC. The KEC reclaims, stores, recycles and supplies power to all inductive loads (motors). As you have already paid for this electricity, why waste a percentage of your investment. With the KEC, energy can be stored and used when needed. This whole process is called energy optimization.

19.3. Specifications of the KEC

- **220** Volt AC application
- Withstands surges to **480** VAC
- Self-healing metalized capacitors
- Low losses, **0.5** watt per Kvar
- UL Recognized Pressure Sensitive Interrupter
- Interrupter for maximum **10,000** amp fault currents
- Discharge system to reduce voltage to 50 volts or less within 1 minute of de-energization.
- Case rupture protection: Internal pressure sensitive devices incorporated to activate at end of life or misapplication.
- Operating temperature range of **-40°C** to **+90°C**
- Flashpoint: **+ 182°C** to **+ 200°C**
- Values **+/- 2%** of rating
- Hermetically sealed aluminum case with turn plate steel cover
- Phenol insulating bushings
- Box size **6" x 6" x 4"** up to **12" x 12" x 12"**
- Operating Life: **60,000** hours with **95%** survival
- Wire Rating: **600** Volts, THHN or MTW or THWN or AWM, Gasoline & Oil Resistant **11**.



19.4. KEC Installation

Installation is quick and the savings are immediate.

KEC panel mounted system is attached to the top breaker on a 100, 200 or 400 amp single or three phase service panel. By installing KEC in this location, you are optimizing both sides of the bus bar in your panel and insuring whole facility surge protection. KVAR® KEC panel system can be installed outdoors or indoors.



Conclusion:

Inductive load consumes reactive power (magnetizing power) in addition to the active power to do useful work. Reactive power required by inductive loads increases the amount of apparent power (measured in kVA) in the distribution system. The apparent power depends on power factor and this is important because a low power factor can waste energy, result in inefficient use of electrical power, and often result in higher energy bills.

The other common problem is harmonics, these harmonics make the value of current and voltage unstable and it is a serious problem that can be harmful for drives and devices.

In this study we discussed a certain techniques and methods for overall power quality improvement aiming to reach satisfied results because a lot of applications can benefit from it: Commercial and industrial because their loads include induction motor driven equipment such as elevators, pumps, presses, DC motors, power transformers, welding machines, and arc furnaces are mostly inductive in nature.

By implementing KEC technology at individual inductive loads, the KVARs required by the motor are provided by the KEC unit rather than the electrical system. Consequently, the power used from the electricity provider is mostly kW.

References:

*Hauth, R.Moran, *an Introduction to Harmonic Analysis*. IEEE Tutorial Text 78EH0135-4-PWR, IEEE Summer PAS Meeting, Ca, July 2011, pp. 48-55

*Sugawara, I., Suzuki, Y., Takeuchi, A., & Teshima, T. *Experimental studies on active and passive PFC circuits*. INTELEC 2010, 19th International 19-23 Oct 2010. 571-578
Doi 10.1109 / INTELEC.2010.646051

*ON Semiconductor (2009): Power factor correction handbook. Retrieved from http://www.onsemi.com/pub_link/Collateral/HBD853-D.PDF

*Meter and Instrument Department, *Manual of Electric Instruments Construction and Operating Principles*, Manual GET-1087A, General Electric Company, Schenectady, New York, 2008 pp. 66–68

*IEEE Std. 100 Authoritative Dictionary of Standards Terms, 7th edition ISBN 0-7381-2601-2

*Ed. L. L. Grigsby (2009), *the Electric Power Engineering Handbook*.