

Stoner 63

Assembly Guide



Overview

This is the official parts and assembly guide to the airsoft Stoner 63 and its variants. Here, you will learn the ins and outs of the airsoft Stoner 63, how to put it together, and what parts you will need to do so.

Introduction and Info

Origin

The real Stoner 63 was designed to be a modular weapon system, being able to be converted from a rifle to light machine gun to light automatic rifle (top mag feed). The 3d printed replica of this firearm is designed to be a semi close recreation of the original stoner 63 in rifle configuration. Various parts and functions are different from the real firearm. Some of the parts are different because of the geometry of the gearbox (like the grip angle), and others are for reinforcement of generally weak areas / parts (like the barrel).

Design philosophy

The 3d printed Stoner 63 was made to be as durable as a 3d printed replica of its size can be. The receiver has plenty of material and the barrel is nice and thick, all to maximize strength. The only real weak areas are where these parts have to be glued or epoxied.

Another part of the Stoner 63's uniqueness was all the variations of the rifle that have been made. This includes the survival rifle, RAV02 MC, Robinson arms STANAG mag well lower, and the dutch trials variations. This of course had to be implemented into airsoft. As such most if not all the major versions of the rifle have been recreated so everyone can have a stoner they like.

(example of wood themed furniture)



(example of dutch underfolder)



(example of RAV02 MC upper on Robinson Arms STANAG mag lower)



(example of Survival rifle, Credit to RigsBlackwood on Discord)



Parts and Example links

Regular Ak Internals

- Version 3 AK Style Gearbox with selector lever and motor
 - [JG Complete Full Metal Lipo Ready Gearbox for AK Series Airsoft AEG Rifles w/ Motor](#)
 - Tab on back will need to be removed to fit in Stoner 63

- [LCT Replacement AK Selector Gear Assembly](#)
- Version 3 AK Style Hopup chamber and related parts
 - [CNC MAX Aluminum Hopup Chamber for AK Series Airsoft AEG Rifle by Matrix / SHS](#)
 - [Lonex 50 Airsoft AEG Hopup Bucking](#)
 - [Angel Custom CNC Metal H-Hop Hopup Spacer For All Airsoft AEG \(Type: Set of 2 / Black & Silver\)](#)
- Barrel (length depending on variant chosen)
 - [Action Army Tight Bore Inner Barrel for Airsoft AEG \(Length: 410mm / 6.03mm\)](#)
- Wiring and Plugs
 - [Titan Power Standard Deans T-Plug Airsoft Connector \(Package: 10 Pairs\)](#)
- Grip Screw and Fire Selector Screw
 - M3 Screws, they could also be M4 .7 x 16mm screws depending on the gearbox.
- Battery
 - [Matrix High Output Small Type Airsoft NiMH Battery \(Configuration: 9.6V / 1600mAh / Small Tamiya\)](#)

Non AEG specific Parts

- Springs of various sizes and strengths



- Screws and Nuts for Hopup Chamber



- M2 Screw and Nut for Mag Catch (optional)

Recommended Tools

- Bolt Cutters (for springs)
- Needle Nose Pliers
- Sanding Files
- Small / Skinny Drill
- 2 mm drill bit
- Screw Drivers

Print Orientation

Main Parts

- Lower Receivers

- AK Mag

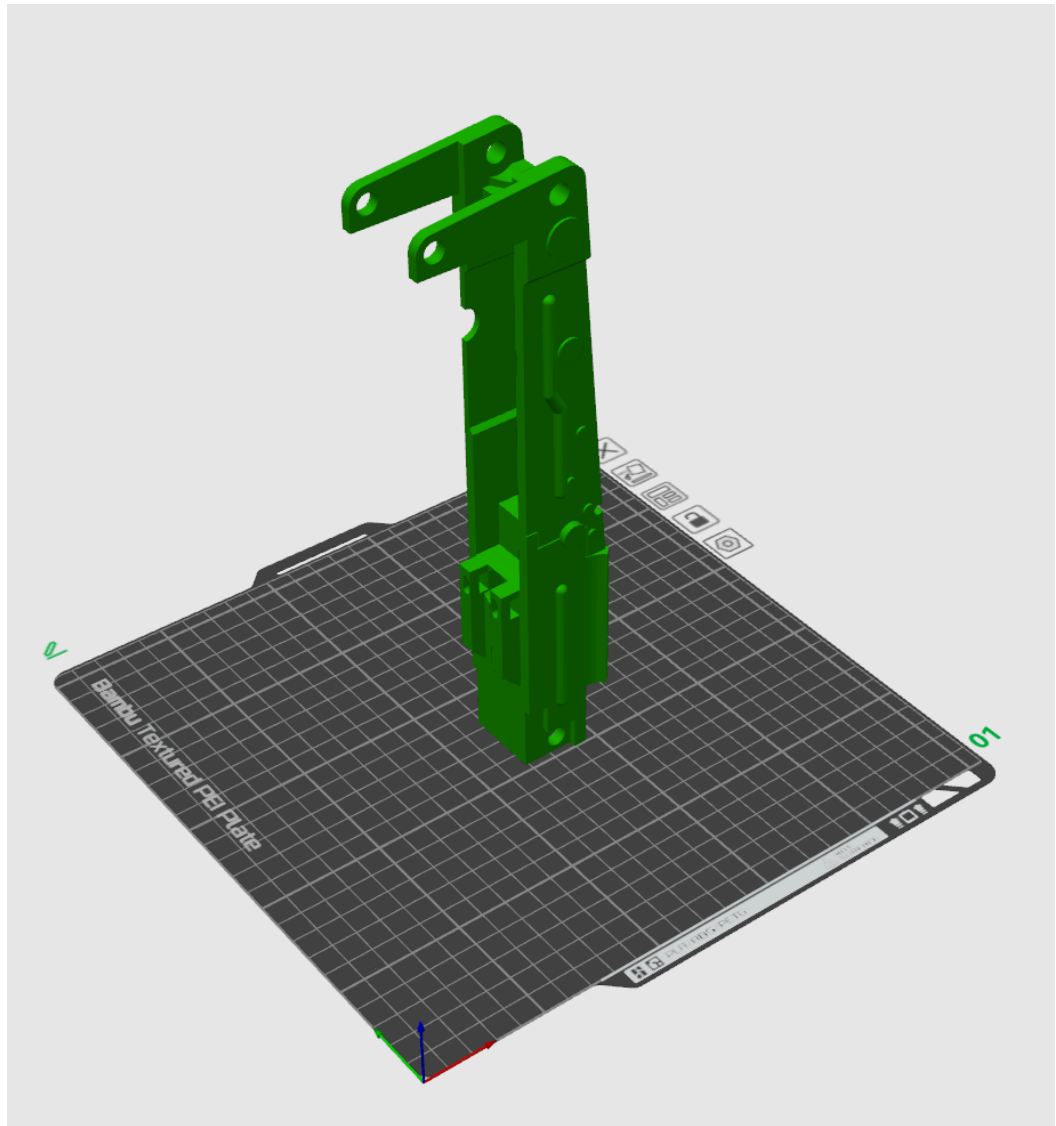

- CYMA Galil Mag (works with Ak mags as well, but catch isn't as good)

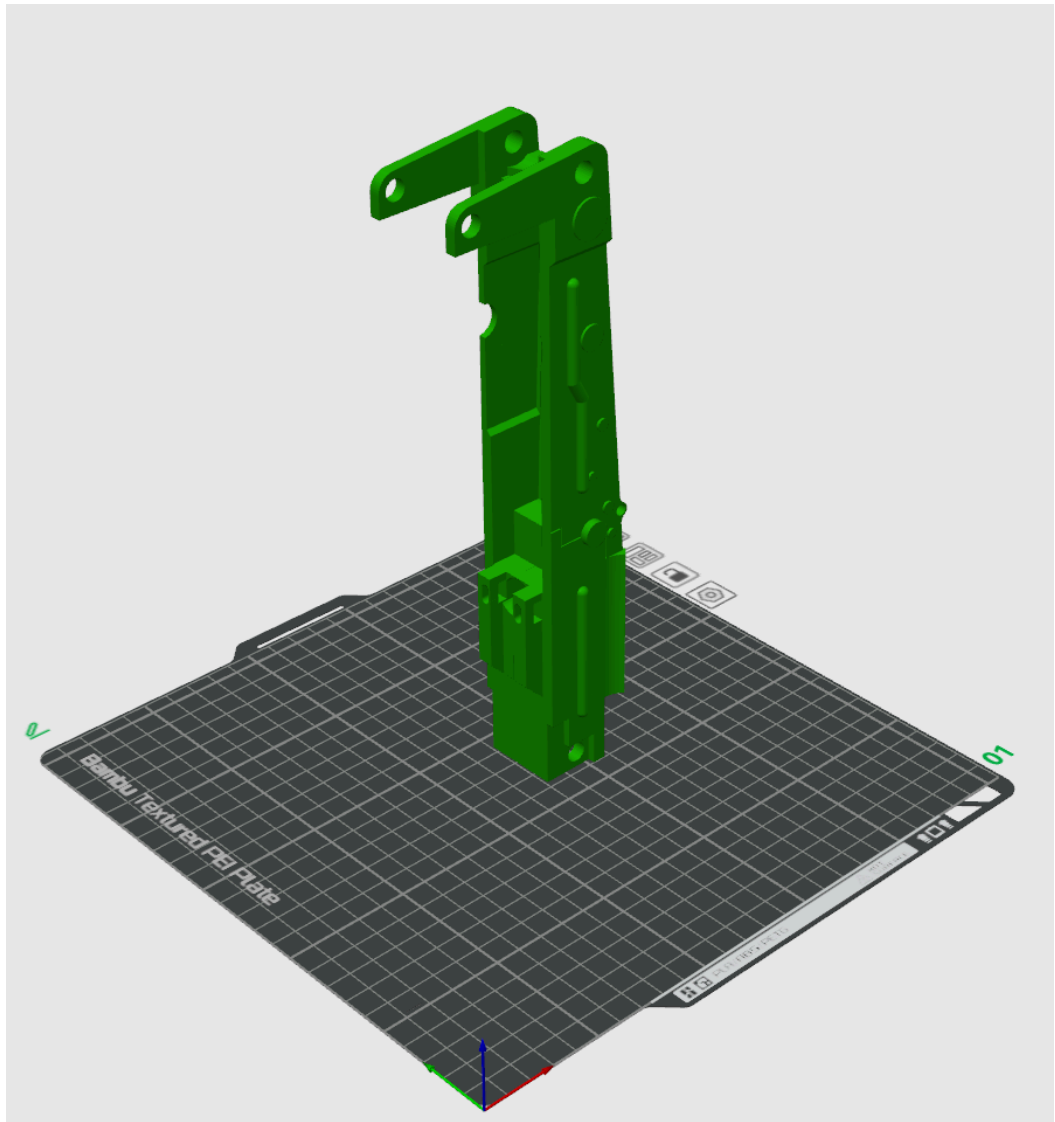

- M4 Mag

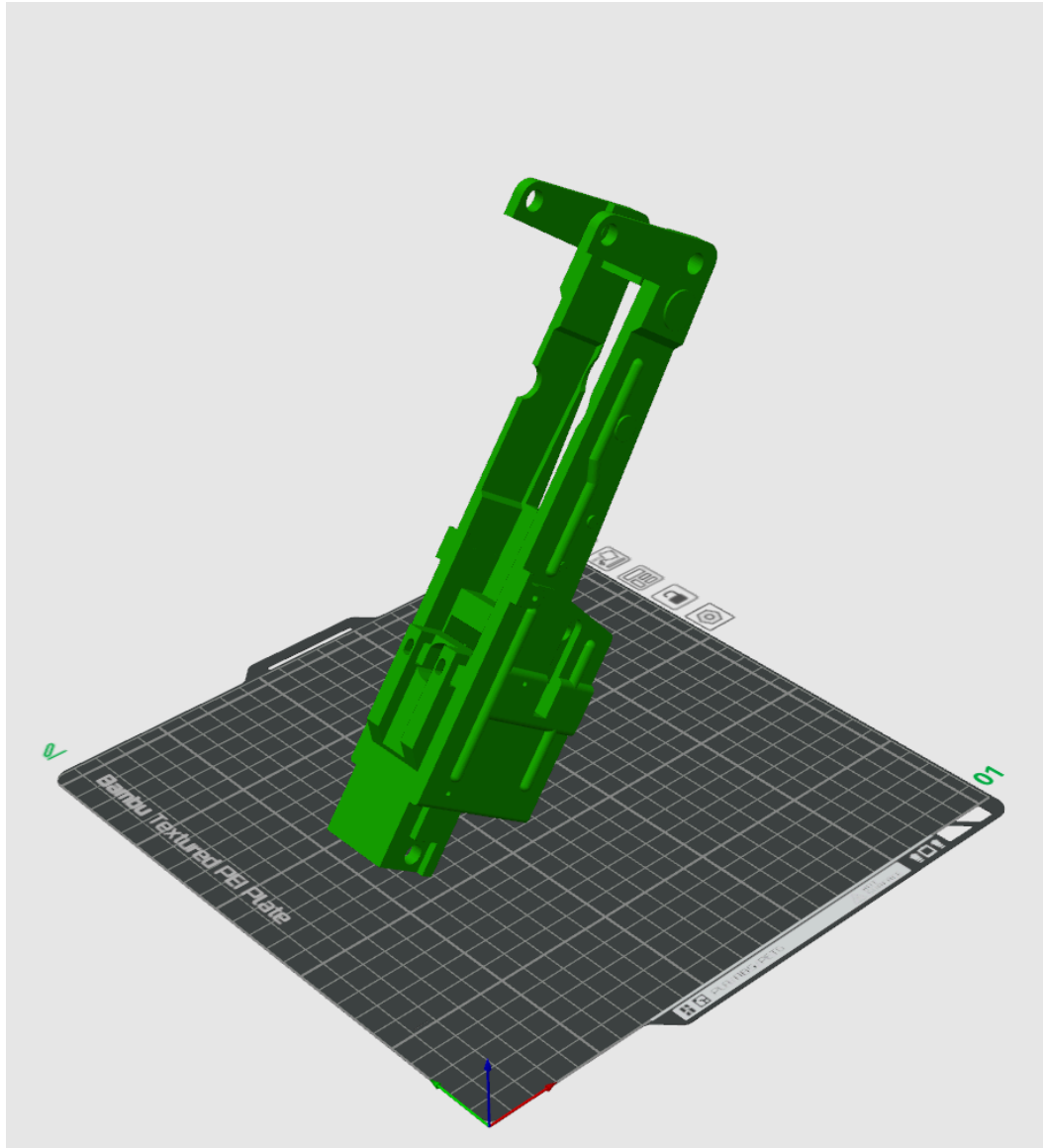

- Upper Receivers

- Regular

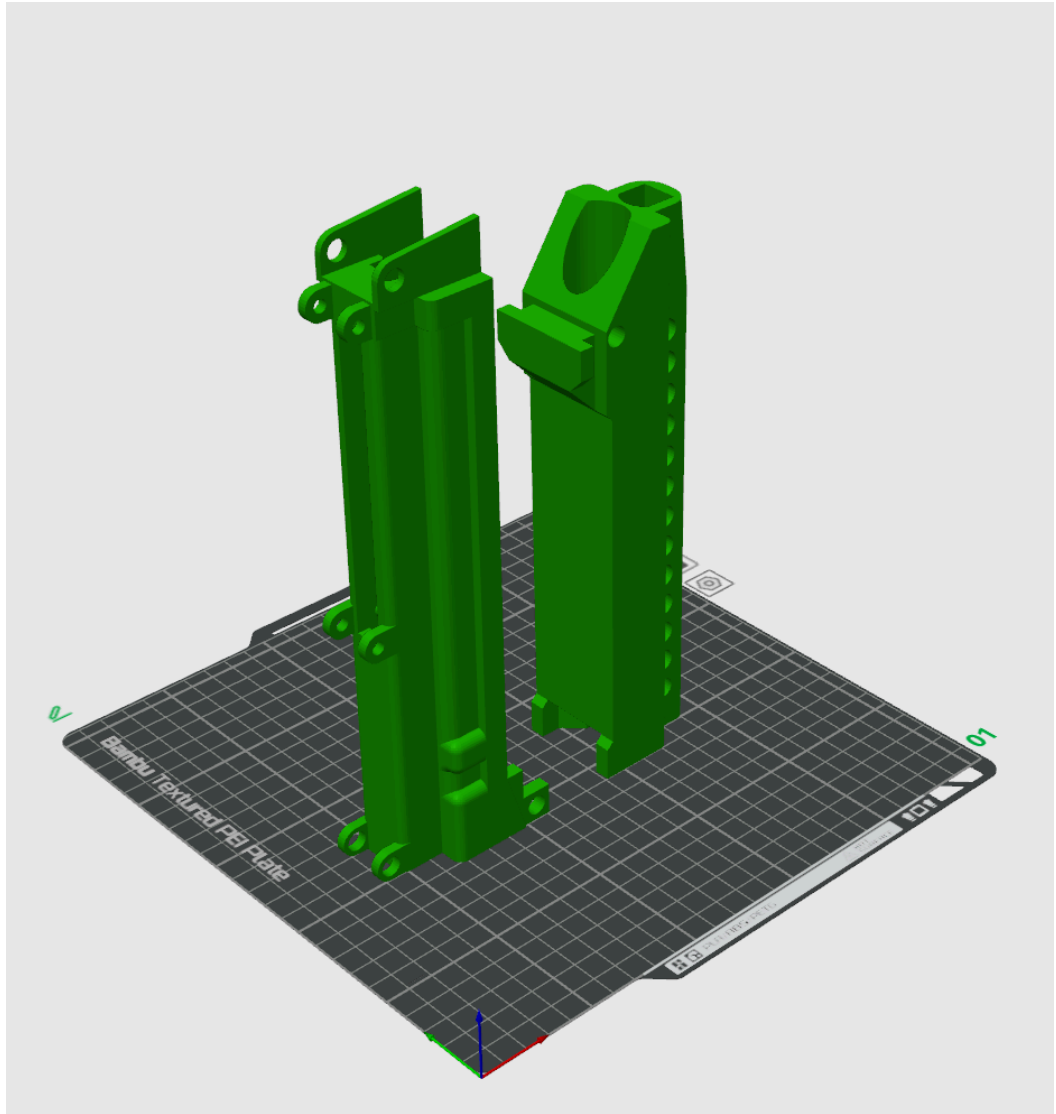

- Survival rifle

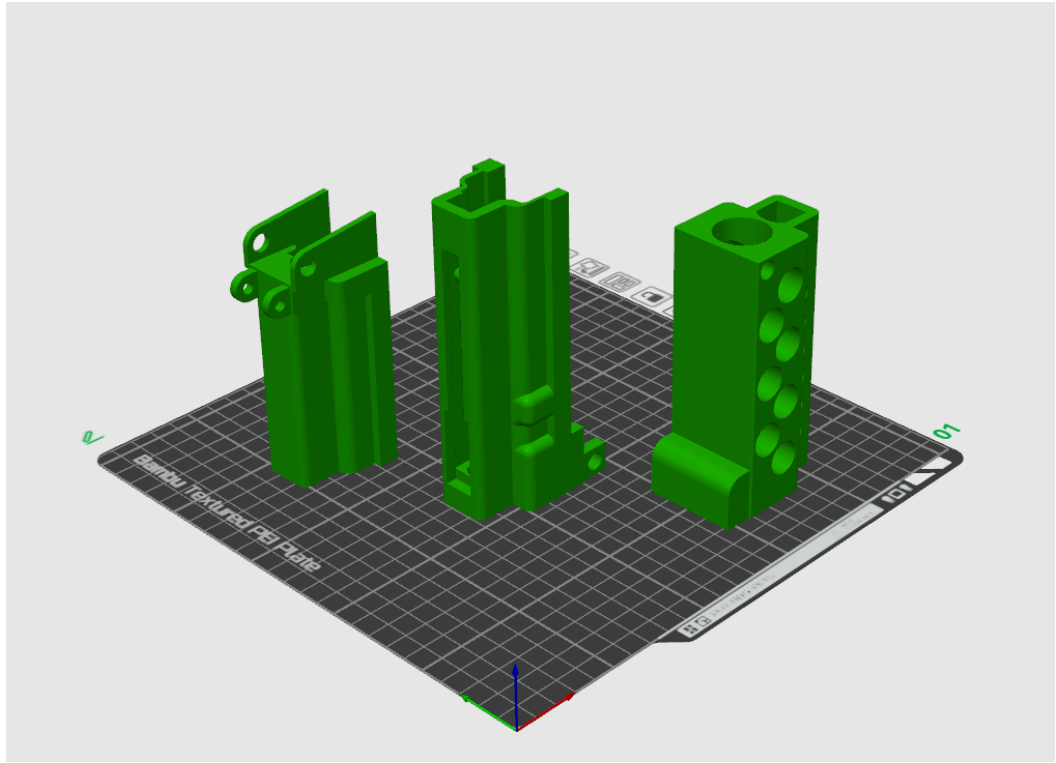

- RAV02 MC

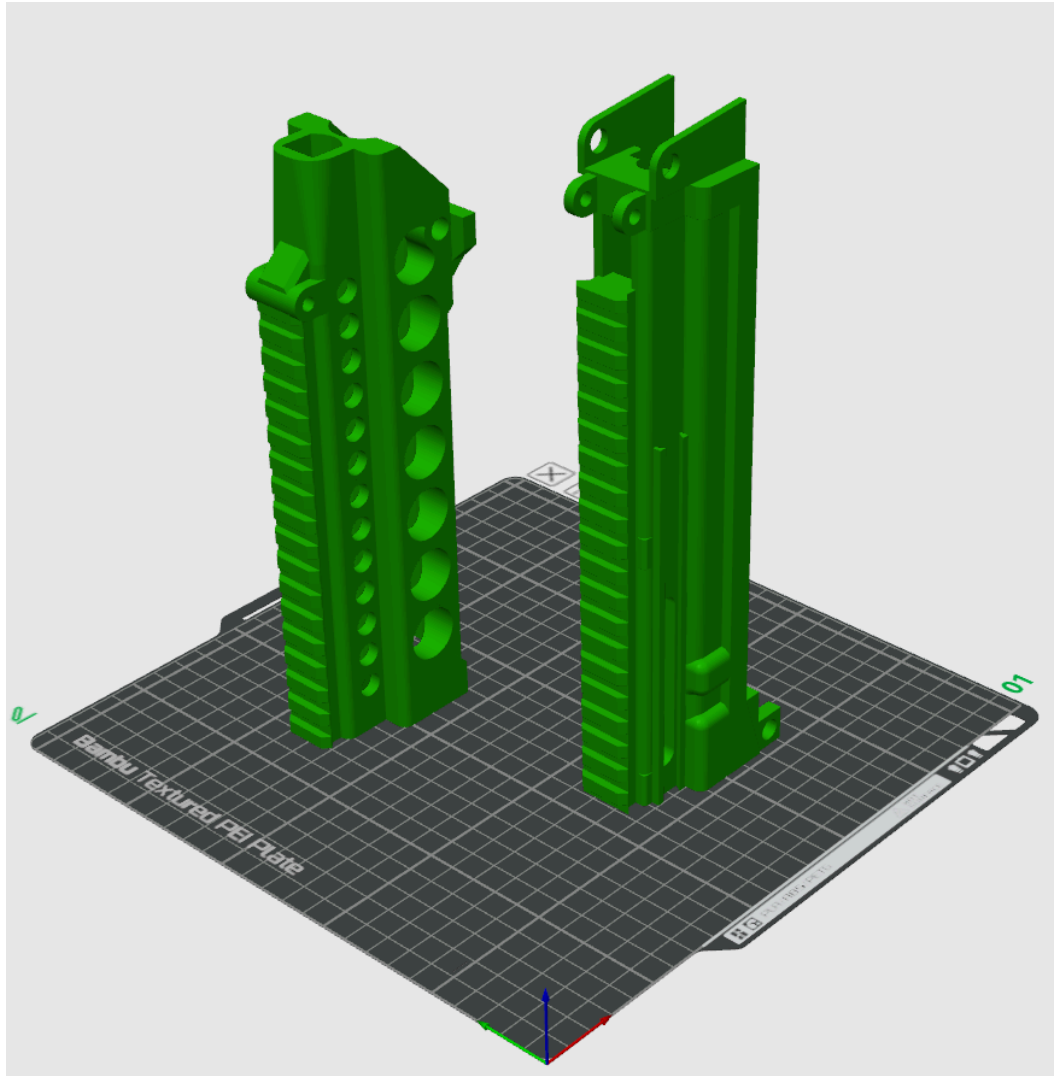

- Furniture

- Pistol Grip

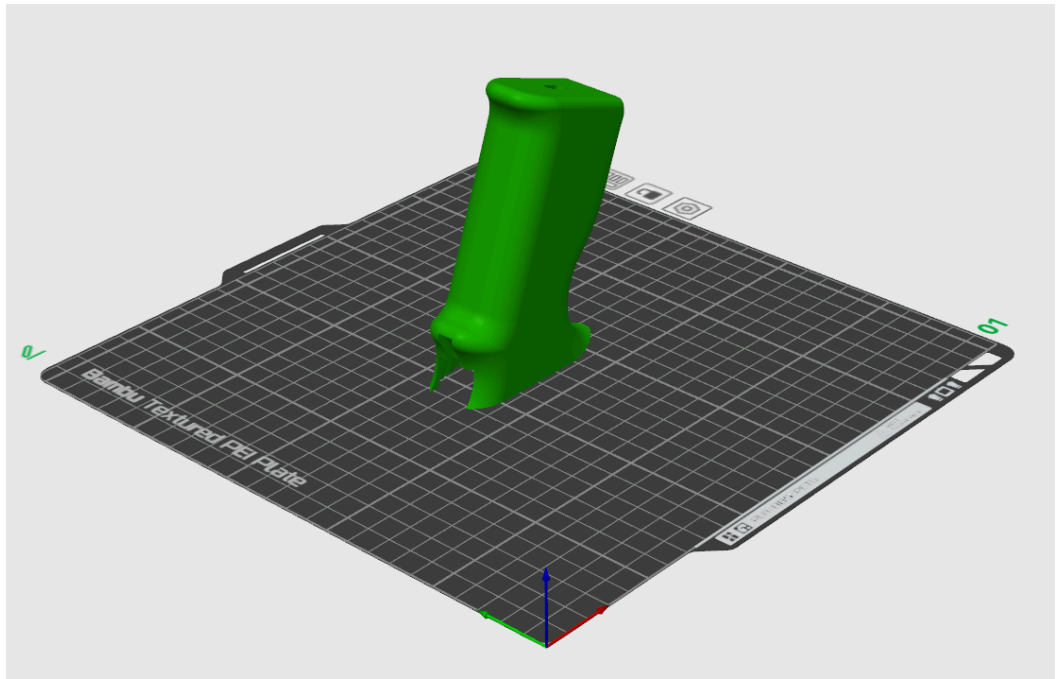

- Front Grip

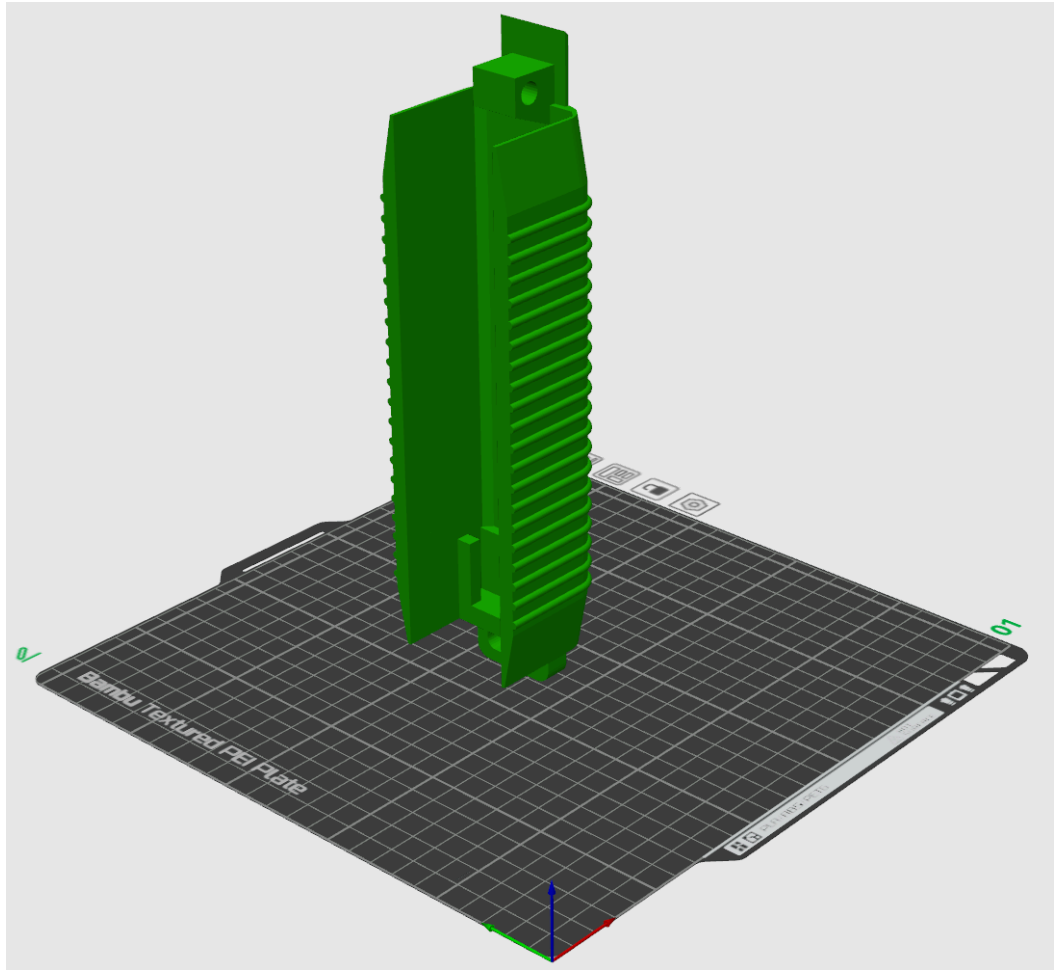

- Fixed stock

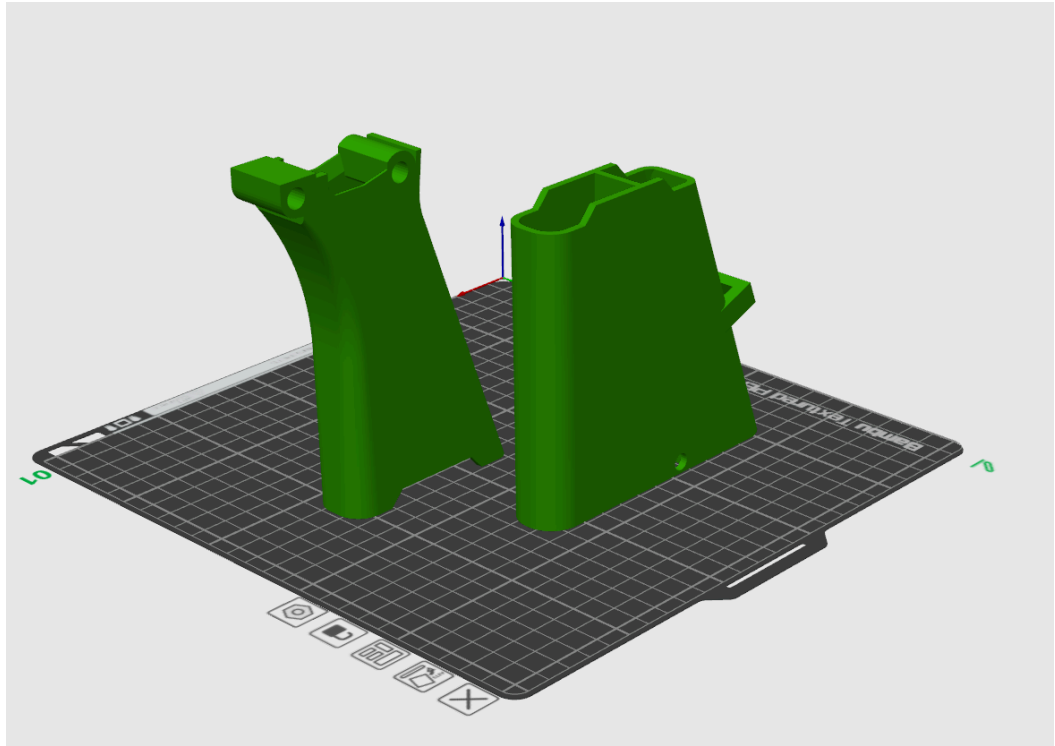

- Bolt

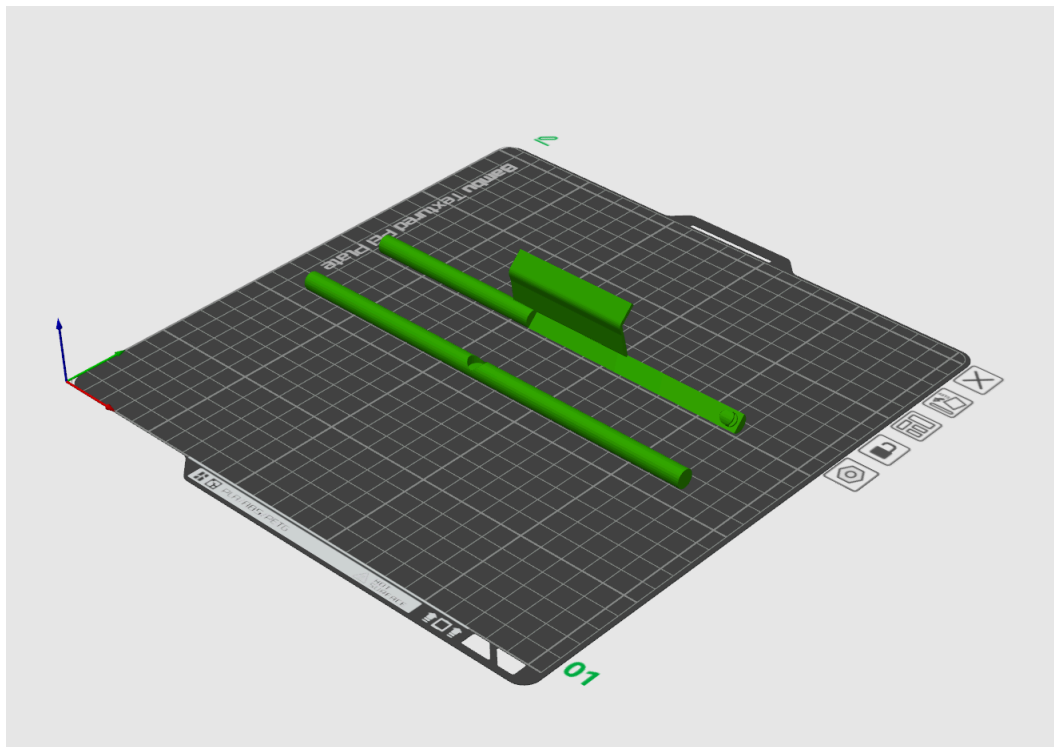

- Pins (all of them)

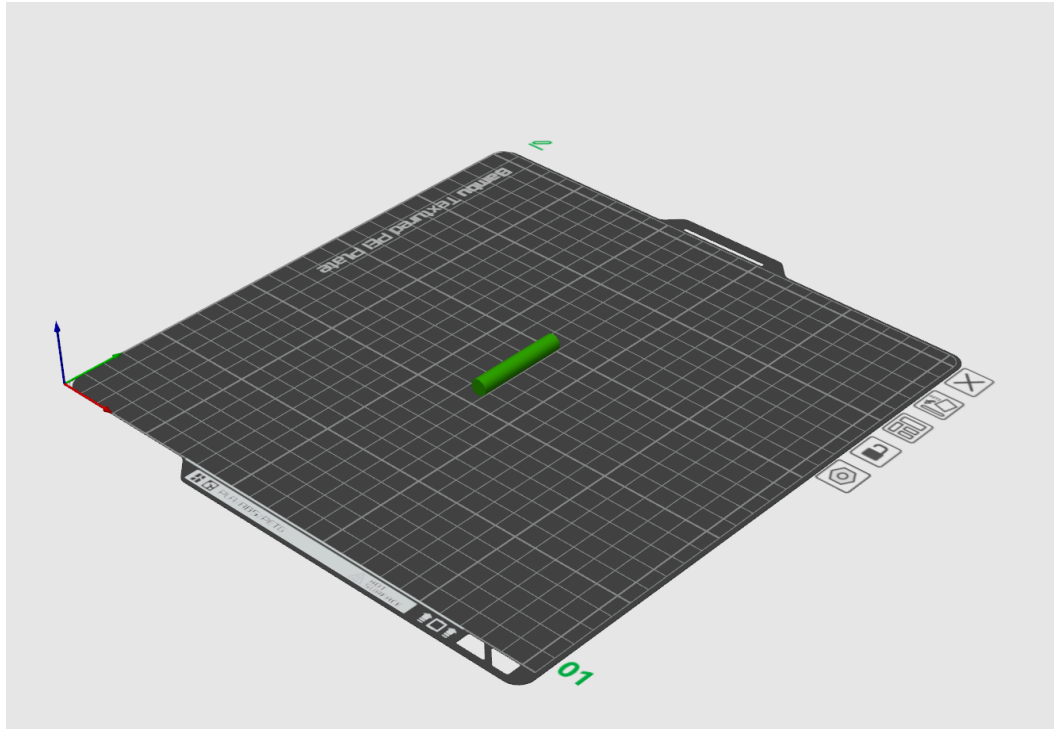

- All other parts can be printed fairly easily, and use orientations that are best for your printer.

Assembly

Off the Print Bed Post Processing

These are just some of the parts that need to be glued or epoxied together after they are printed. Any file that has words like “front” and “back” are like this, as well as any file that is split in the slicer. Other parts (like the gas tube and front sight / gas block) are glued simply because they have no other means of attachment. The others are separated so they can be printed on smaller (and most cases, normal) sized printers.



Some pieces are separated to allow users to use more than 1 color on a part.



Lower Receiver

- Lower Receiver (AK and Galil mag)

- Assemble the mag catch

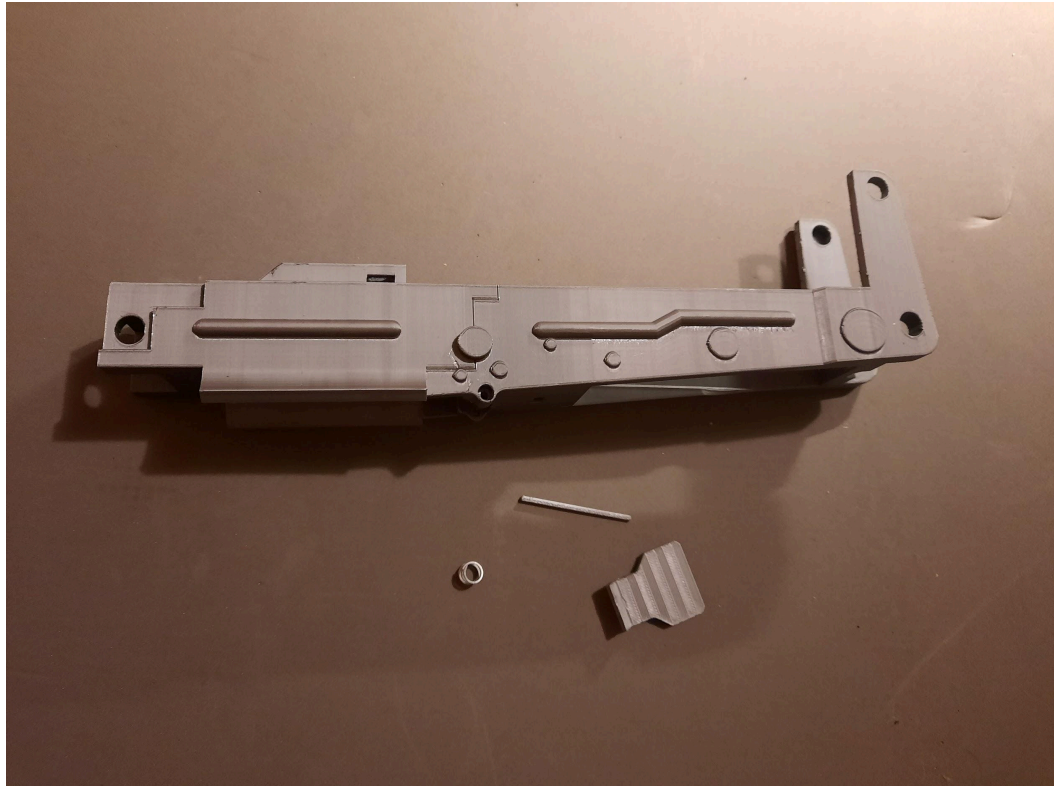

- Inset Spring

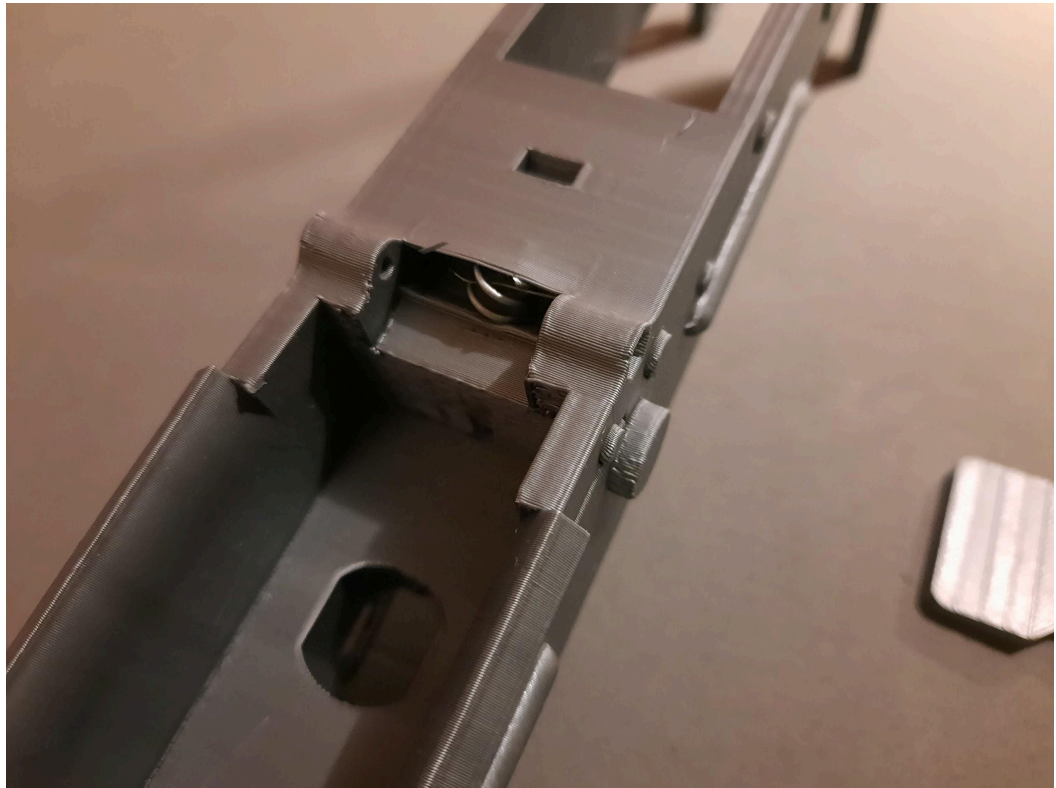

- Insert Catch, as well as pin

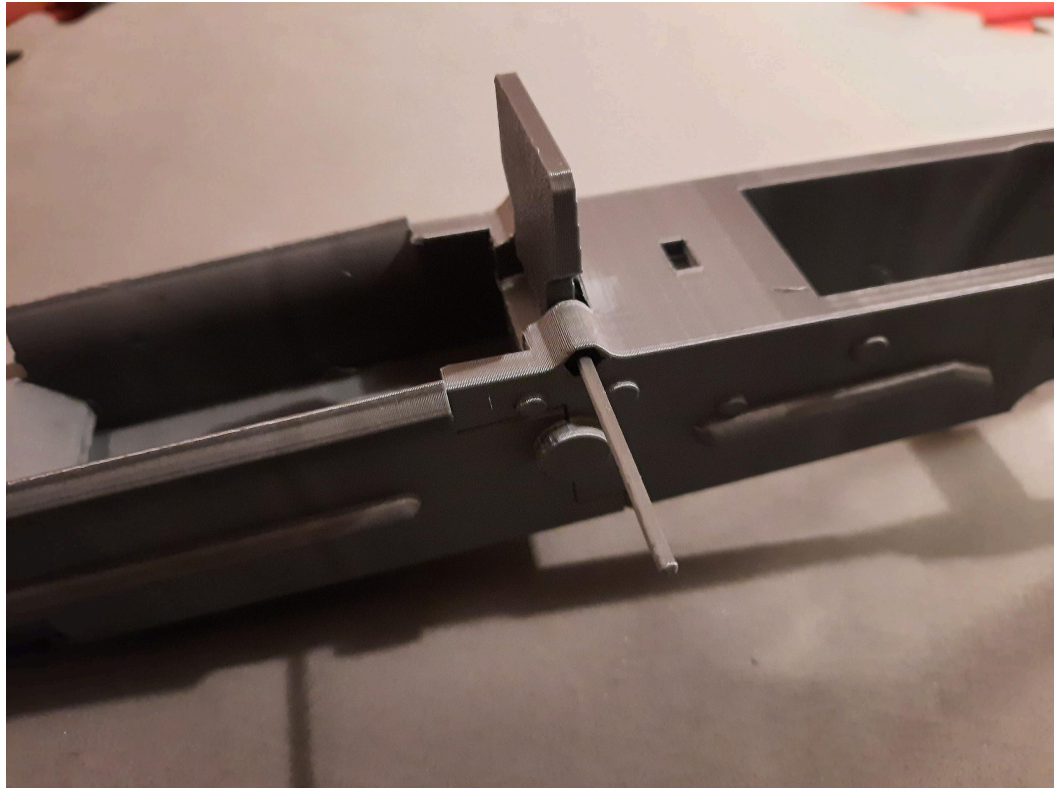

Gearbox

- Gearbox Installation

- Remove the black wire from the motor terminal to allow installation



- Install the gearbox. Note how the black wire is on the outside of the receiver, while the red wire is inside. Room is available for 1 wire in the gap for the gearbox, other wire will need to be outside, running in the channel

in the rear.

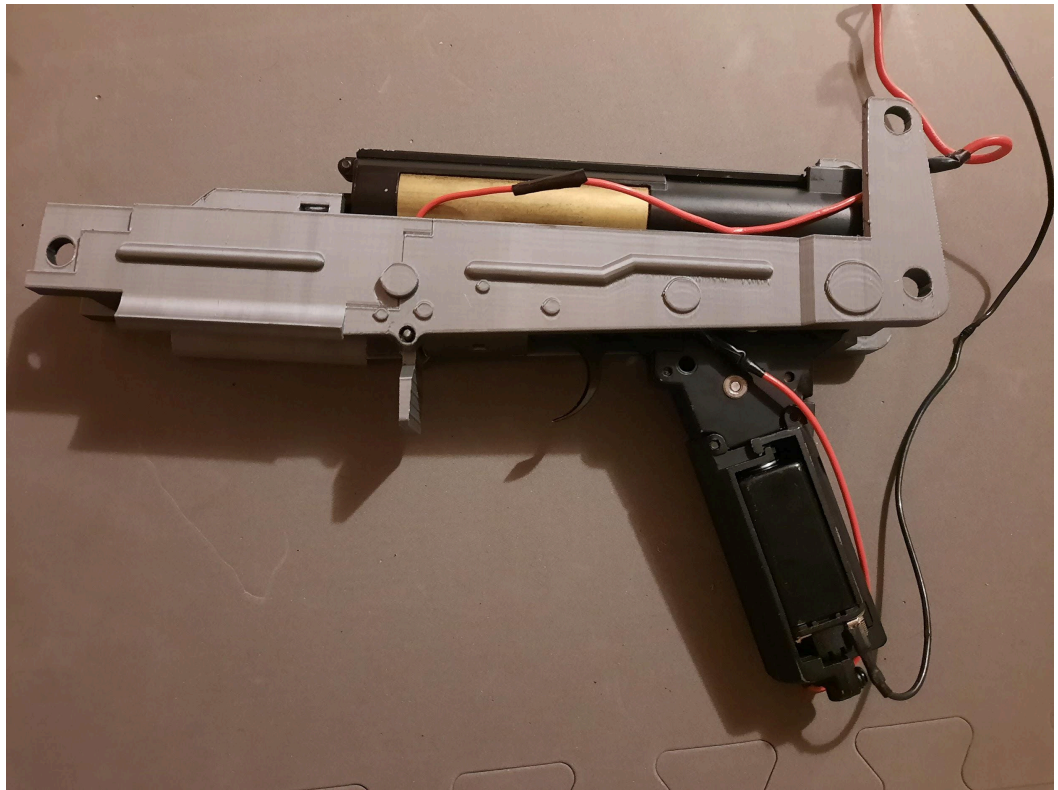

- Rest gearbox against the geometry like so:

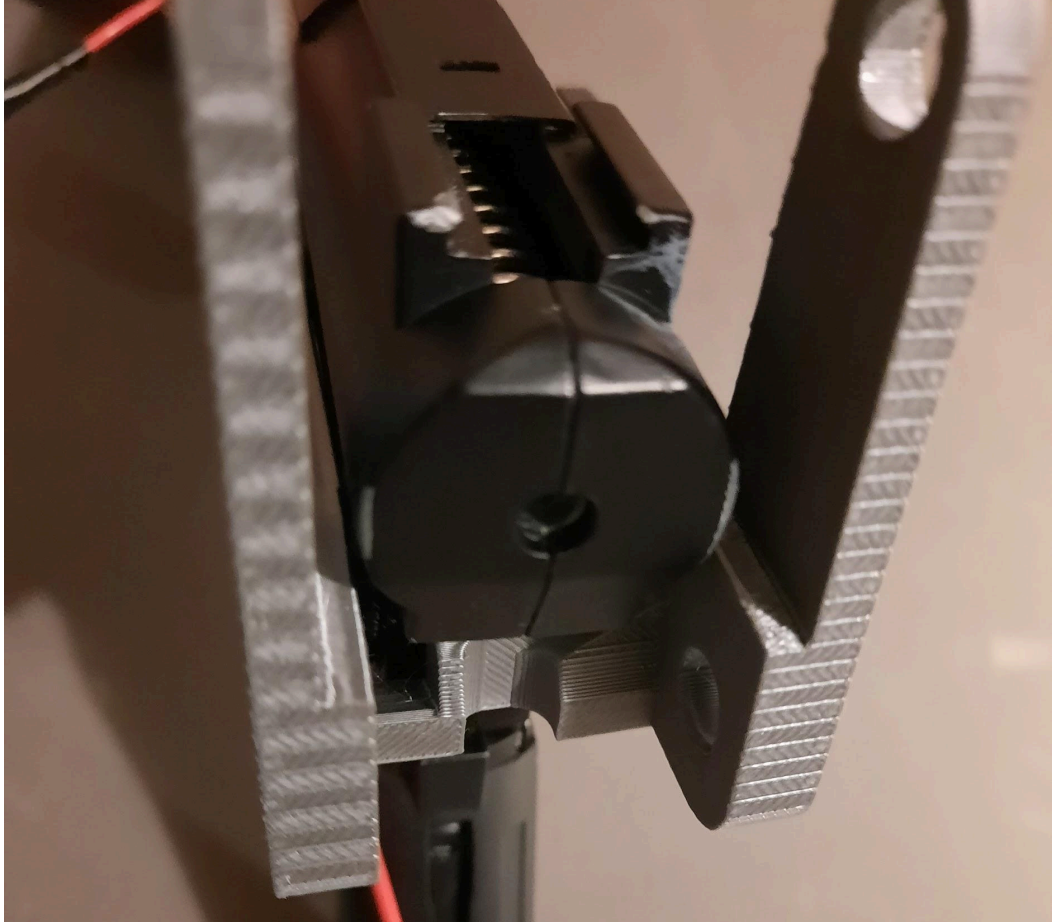

- Install the Hopup. In order to do so, you must rotate the gearbox as such.

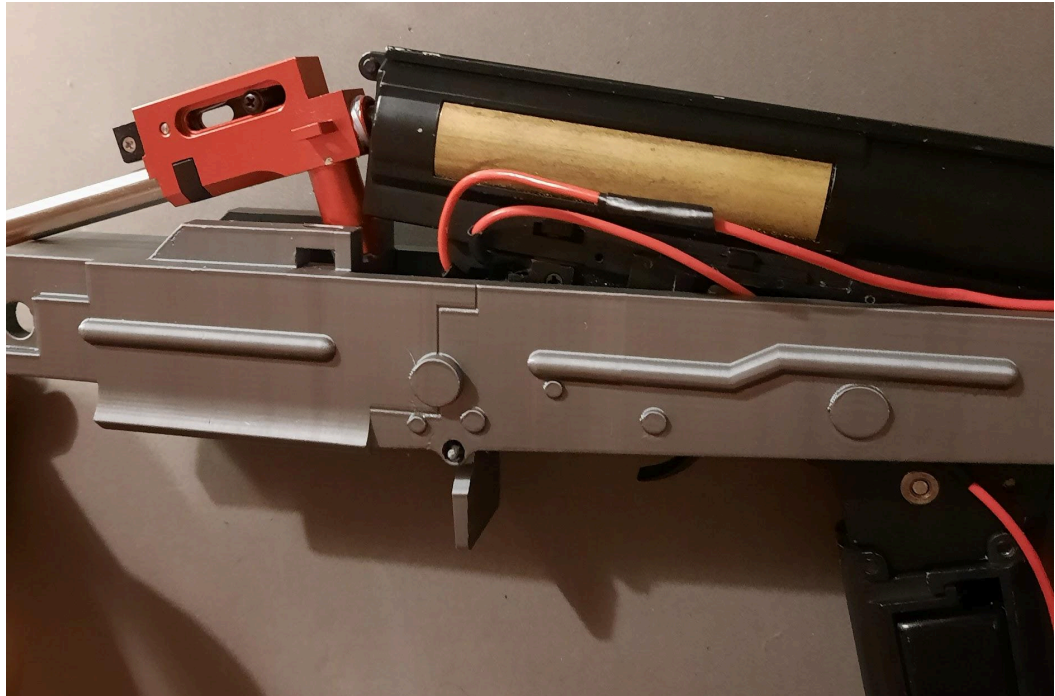

- Install Screws and Nuts. Nuts go into the slot, screws go on top. Washers can be used but are not recommended, due to the need to position the hopup as far back as possible.

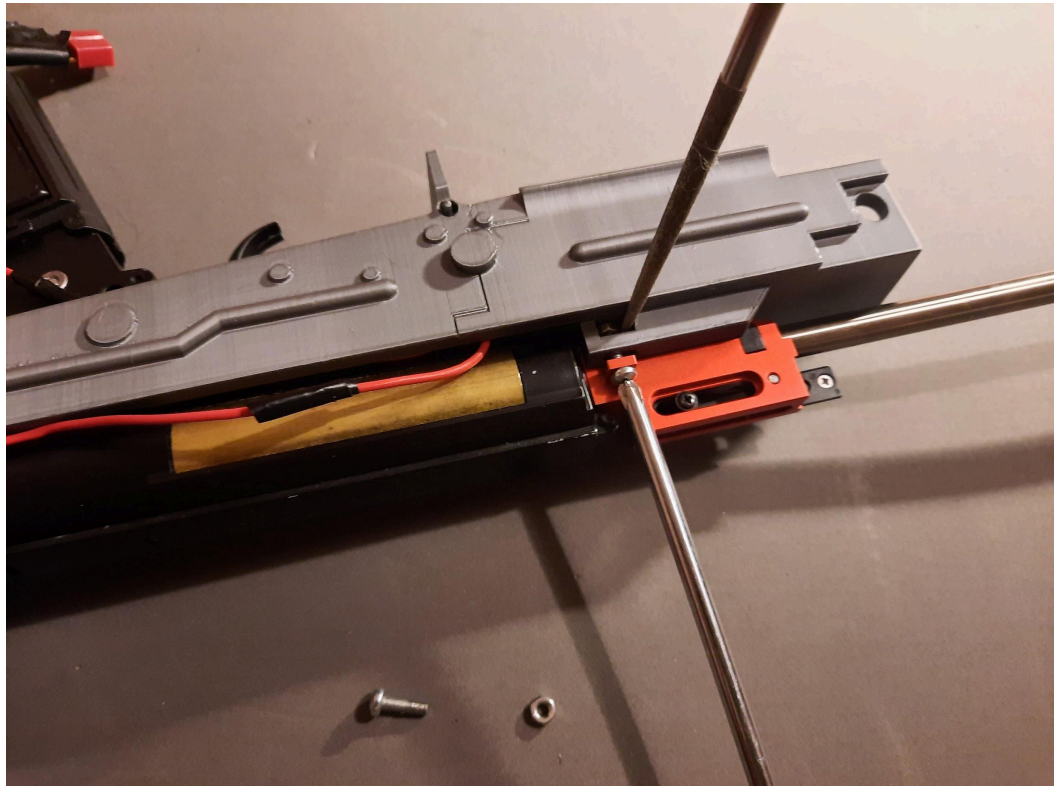

- After both hopup screws are in place, screw the grip into place. Make sure it is tight enough so nothing wobbles.



- Note the wires, especially the black one.



- Decide which way to wire battery, grip or stock

- Grip wire path; wires need to run along the side of the hopup. This is the choice for the rest of the assembly

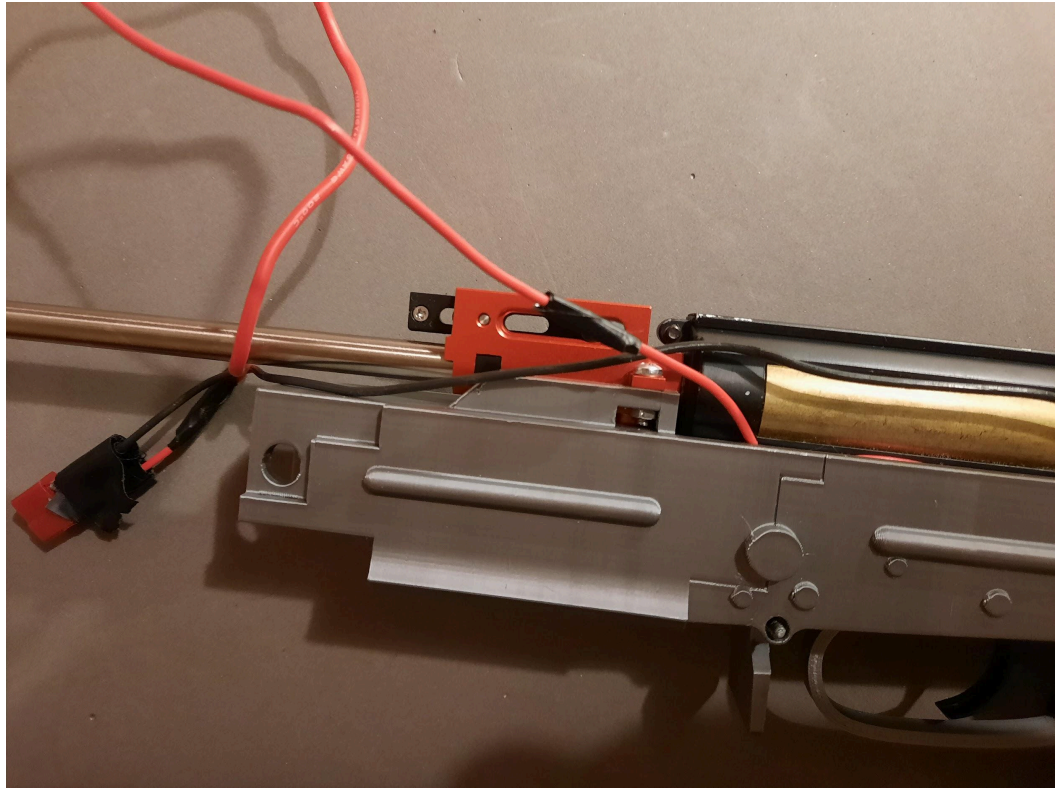

- Rear Wire Path; wire should be as close to the corner as possible.

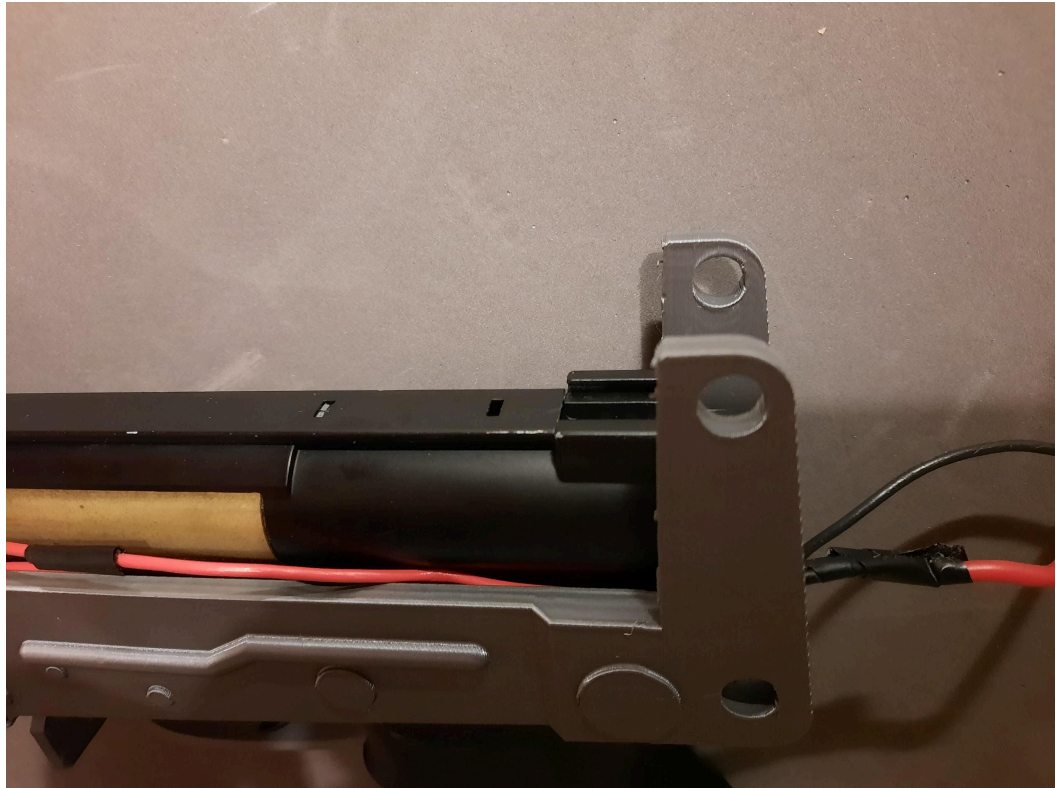

Upper Receiver Assembly

- Installing Dummy Bolt

- Printed parts needed



- Insert the bolt rod into hole, slightly bent and resting against rear of the upper receiver

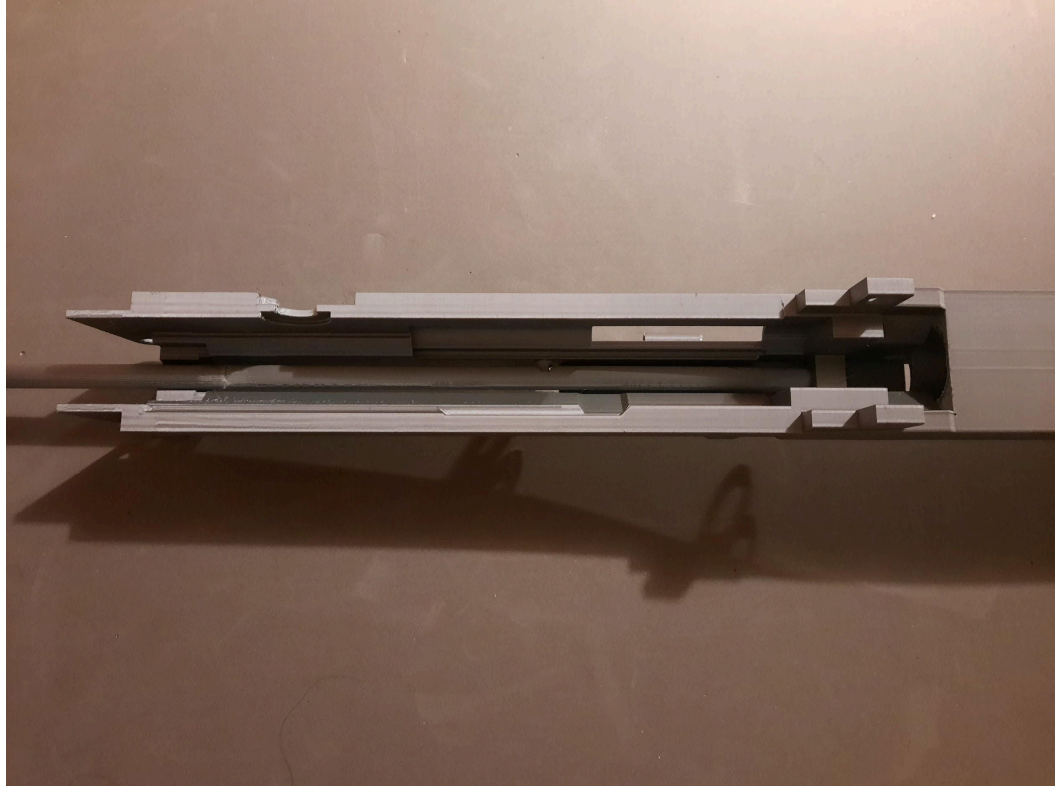

- Push Rod (careful not to break it) until the slot for the charging handle is here:

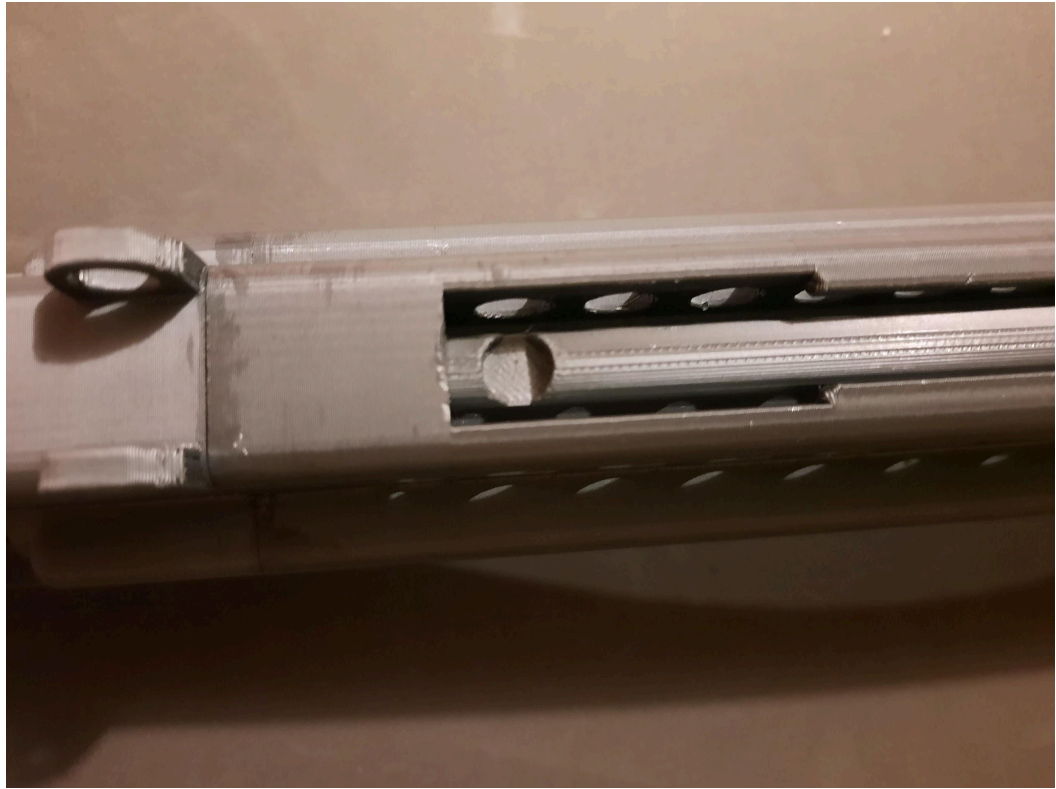

- Install the charging handle. Note the position and orientation, as both are important.

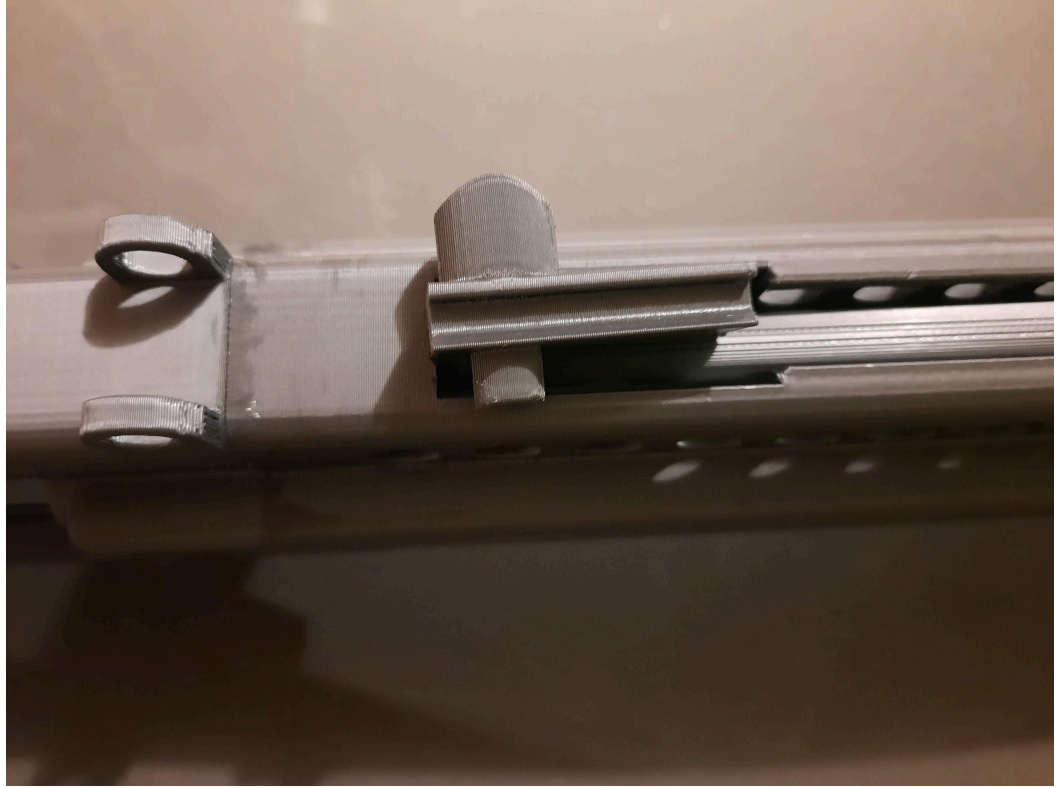

- Note how the charging handle slides in the grooves of the receiver.



- After this point, the bolt is now in its normal travel area, and can freely move front to back.



- Install the spring. It is easiest to do so on the top, where a slot is provided.





- Play with the bolt for a moment, to make sure everything runs smoothly.



- Installing the upper receiver (with bolt) onto the lower

- Parts needed.

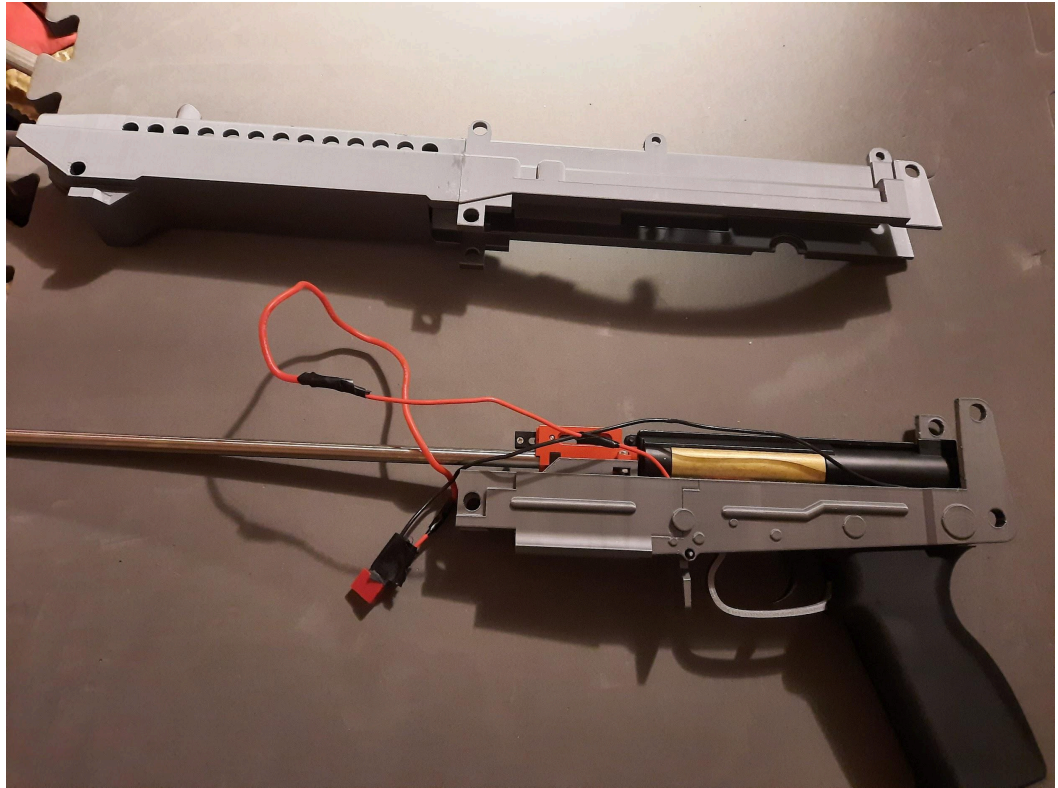

- Start Nose in, rocking the inner barrel into the barrel channel, then level out once inserted part way.

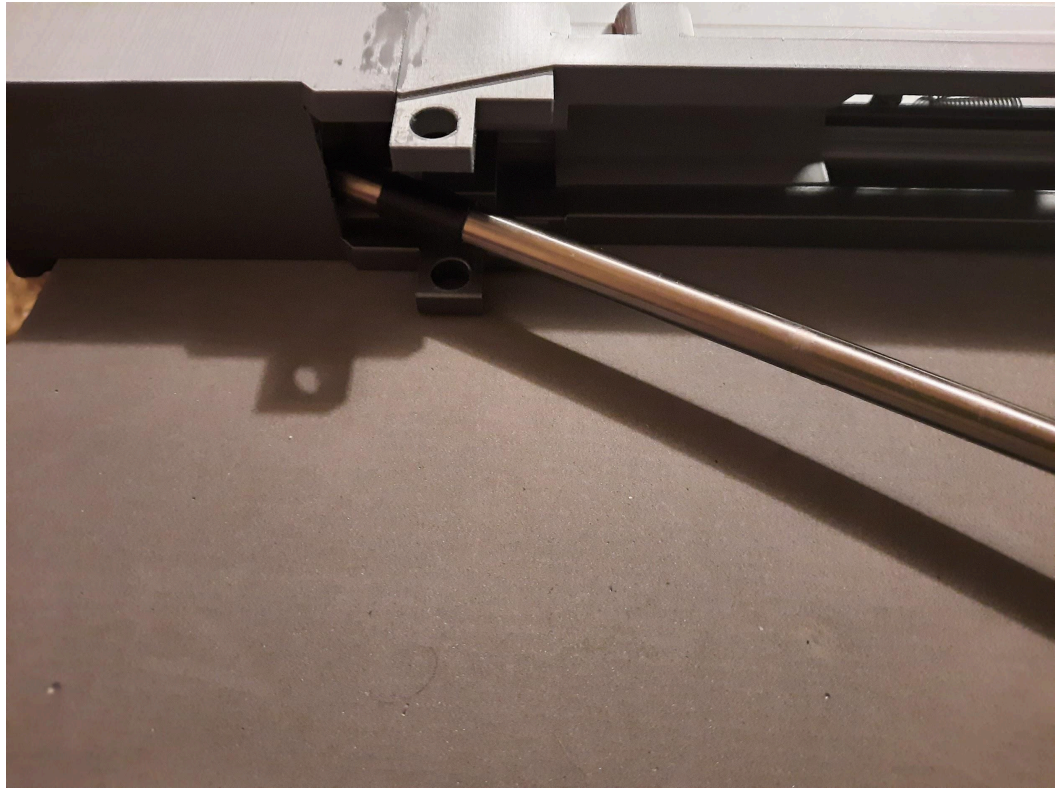

- Like so:

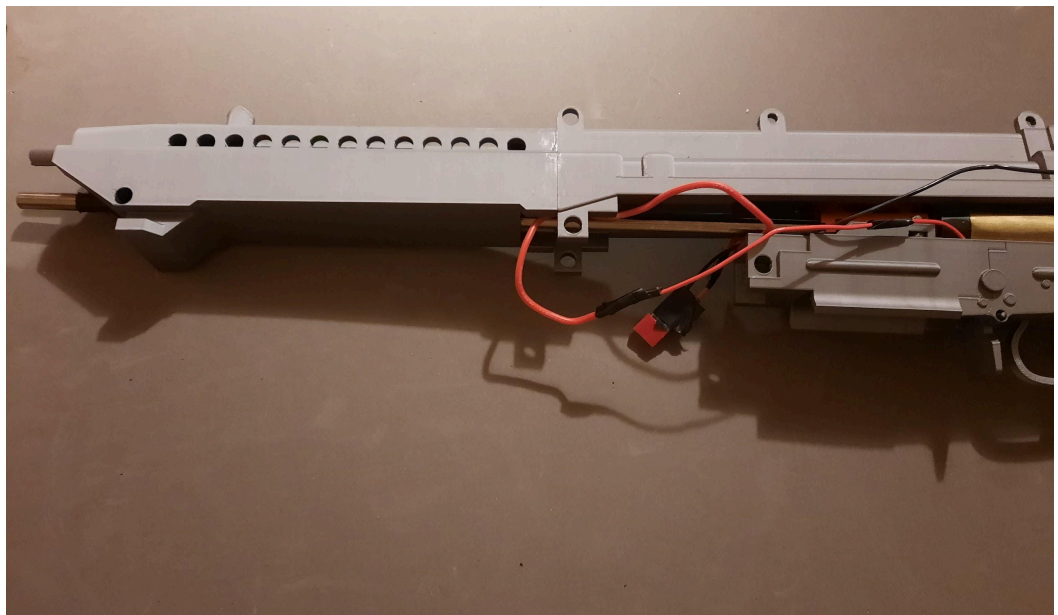

- Place wires in final positions as you close the 2 receivers together.



- For assembly ease, put a body pin in the top rear pin hole to hold the 2 receivers together.



- Install the dust cover

- Installing the dust cover may need drilling, use an appropriate size drill bit to widen the holes so a strand of filament can be slid in to act as a pin.

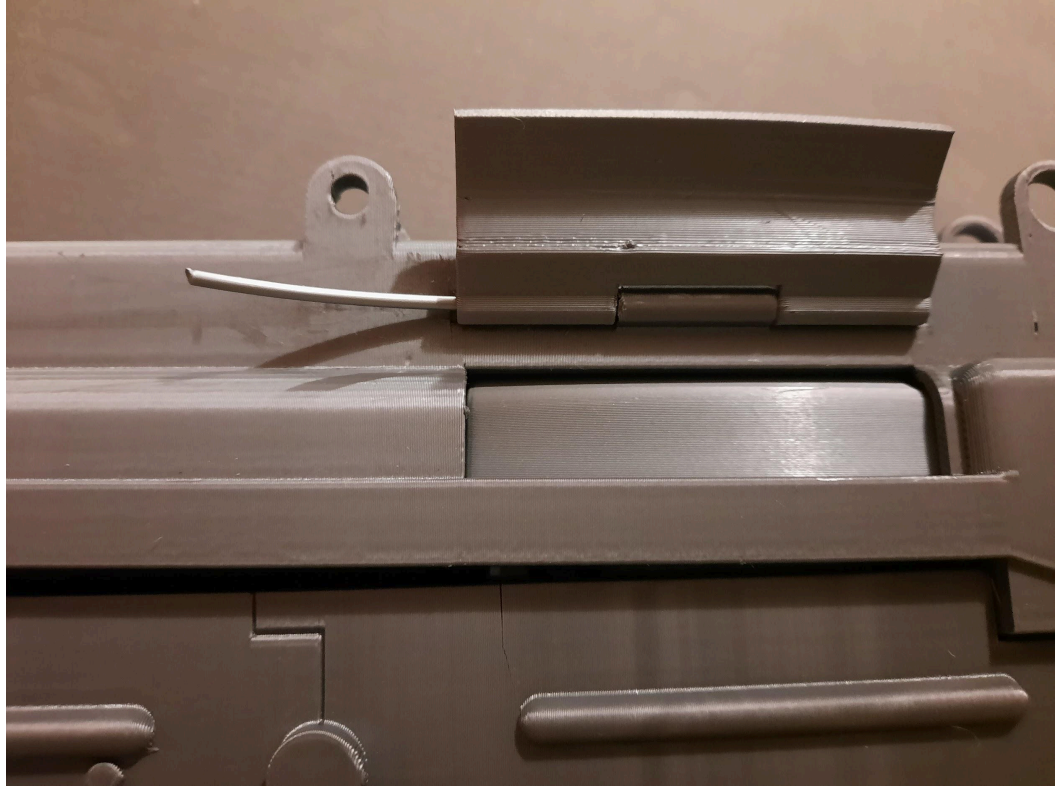

Barrel and Grip Assembly

- Install Barrel and front grip

- Preparing barrel.



- Slide barrel rear first onto the front of the gas block, like so:

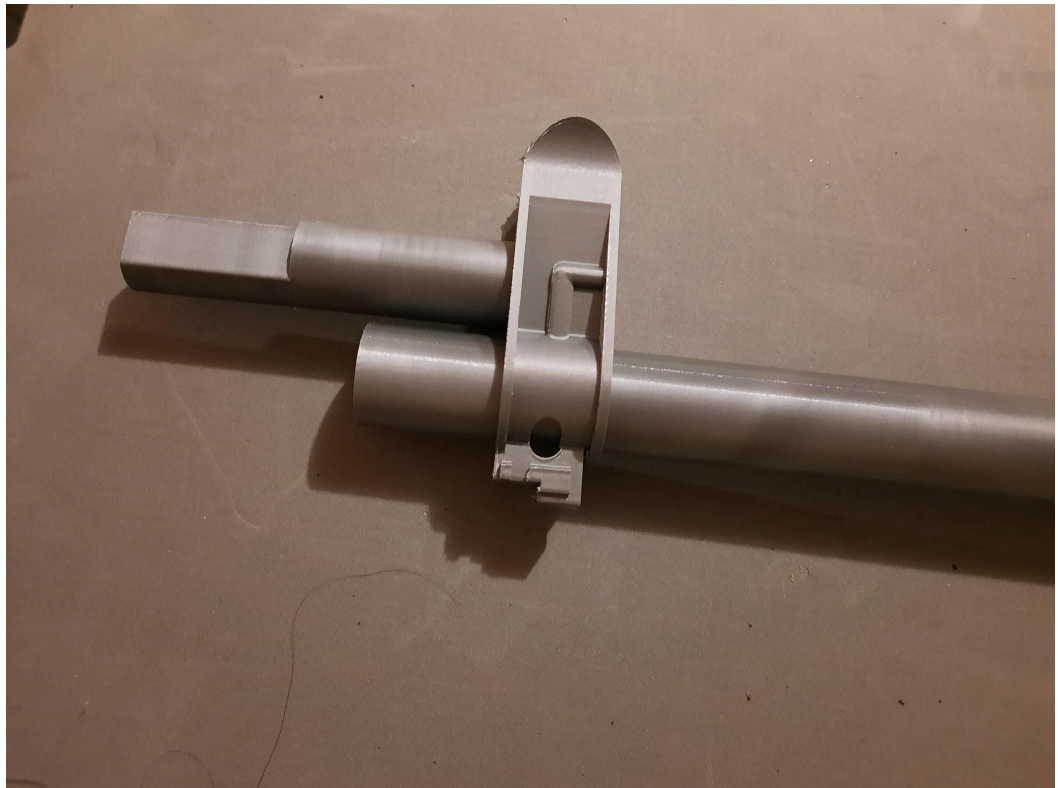

- Pin it in the farthest pin hole with the gas block pin (if no pin is present / available, glue is to be used instead)

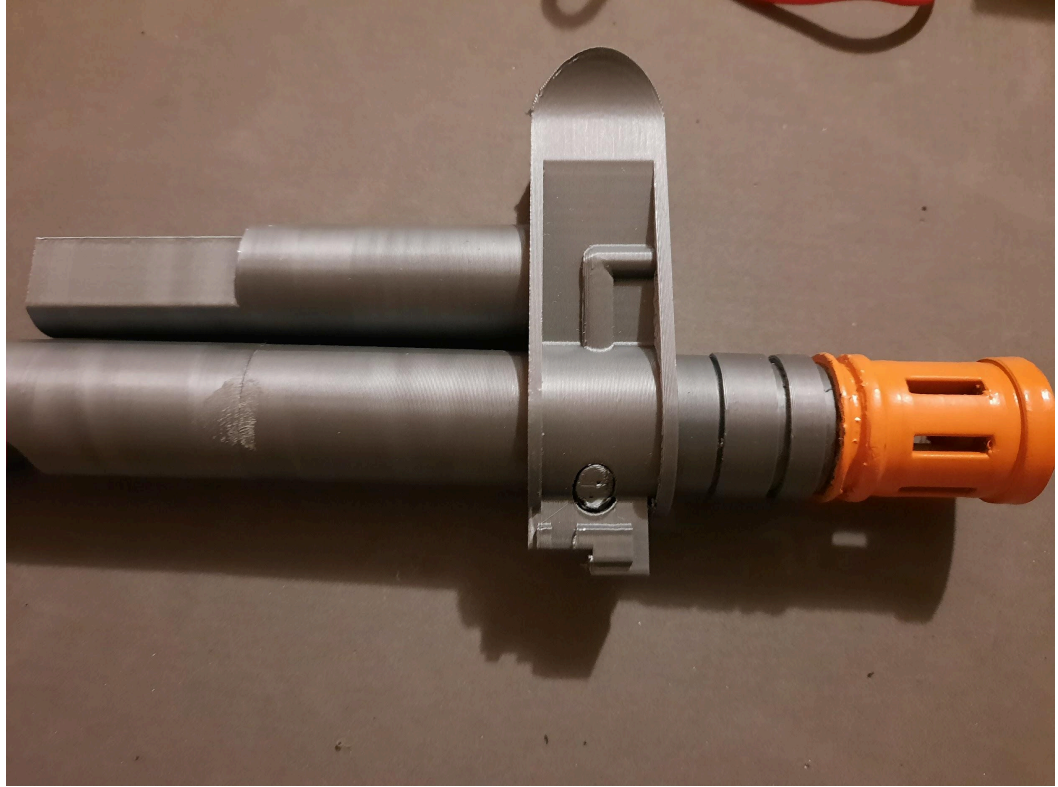

- Begin sliding the outer barrel over the inner barrel (note tape is to match the inner diameter of the outer barrel, so the inner barrel is supported).

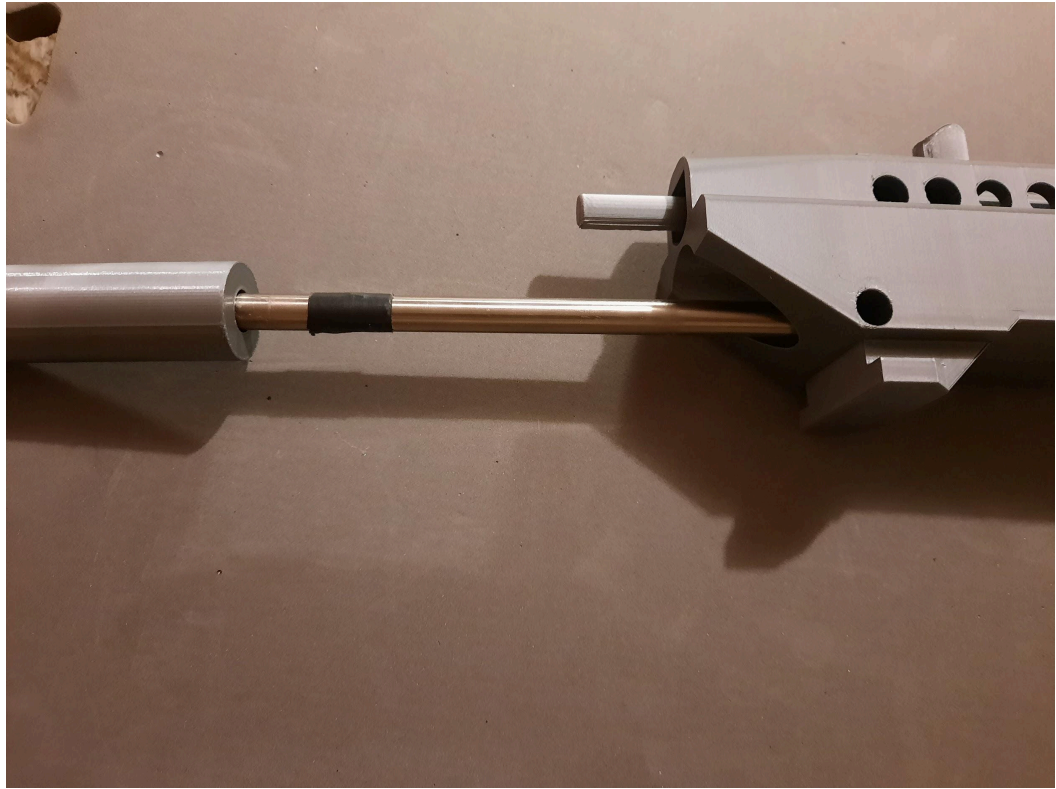

- Slide until it is in position, then pin with a body pin.

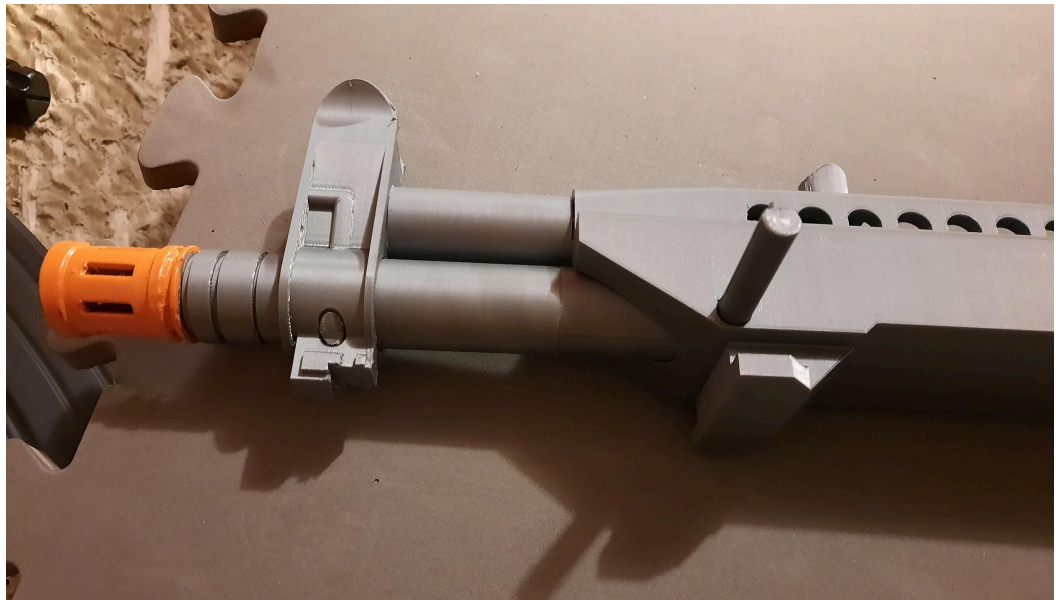

- Feed the wires into the space in the front grip, then slide the grip (with a small angle here and there) till it is in position.



- Pin in place.



Stock Assembly

- Assemble the rear folding stock (can skip if using fixed stock)
 - File down center rod till all parts move freely, then with pegs and springs (not pictured) on, install and glue center rod to the center post of the

stock.



- Install Stock hinge pin into the stock and stock connector piece. Also note how I have had to dremel the holes for the wires bigger to better fit the

Deans plugs.

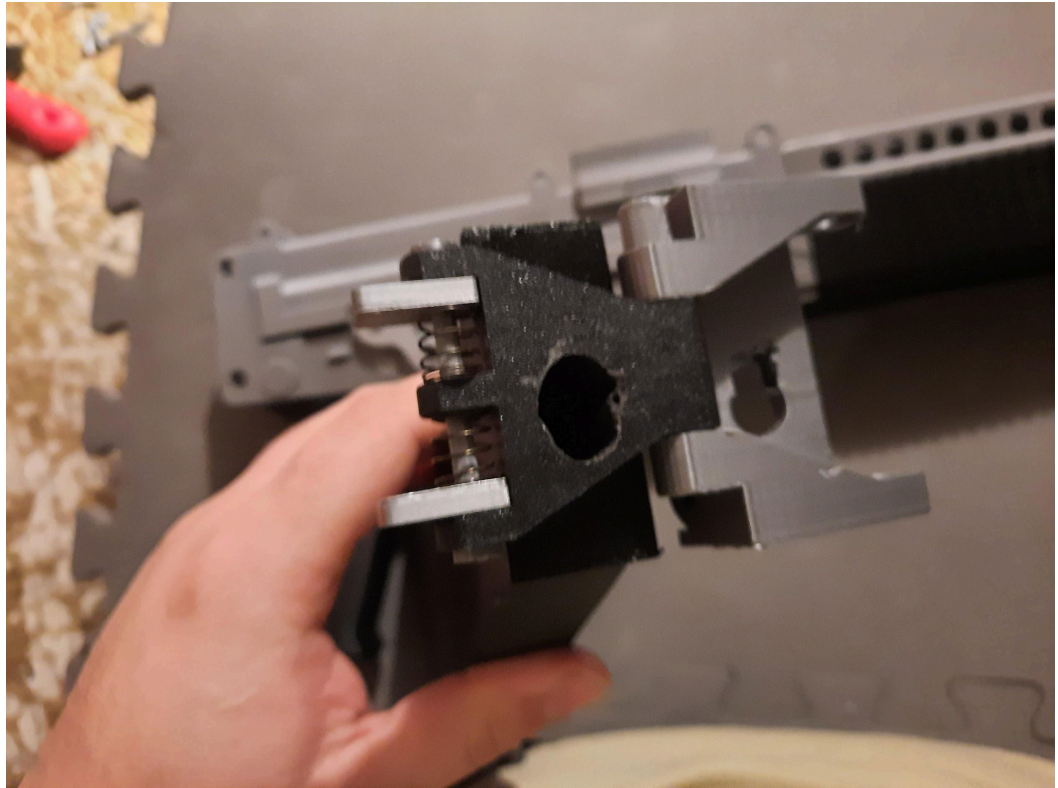

- Note Position where the Stock will go, if you have wired the replica to the rear, then feed wires into the stock now.

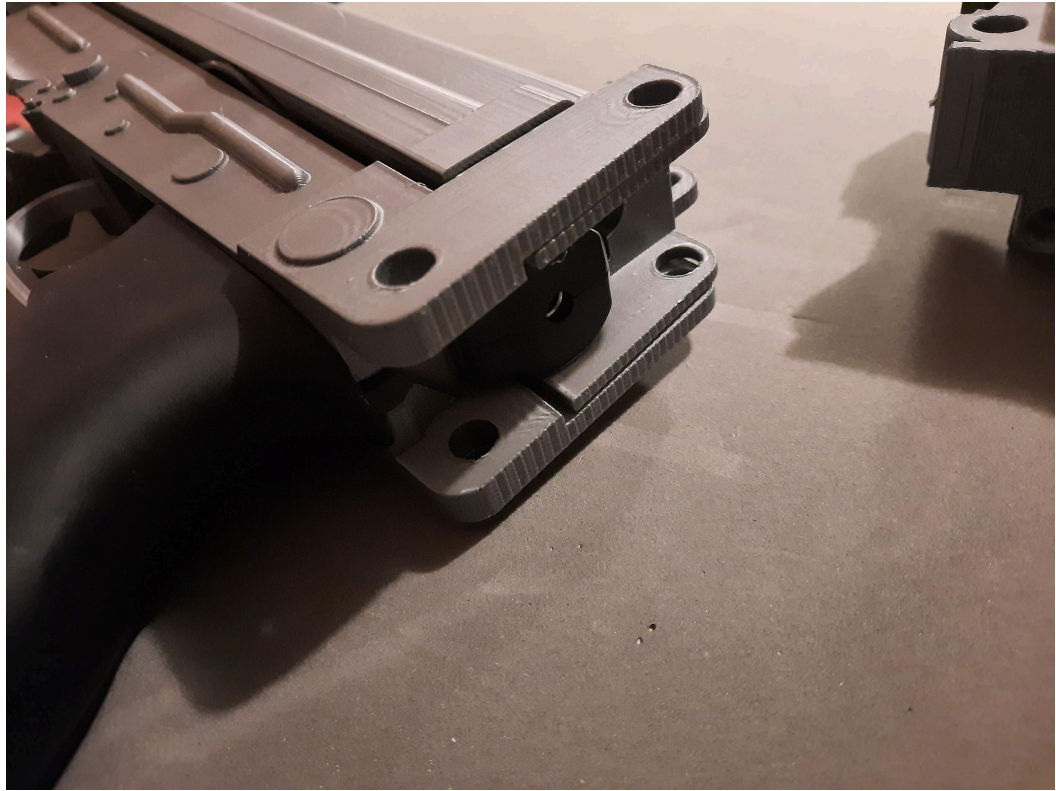

- Install the Stock and Pin in place using 2 body pins



- Install the stock pad and pin it as well.



-
-

Rear Sight / Optic Rails Installation

- Rear Sight

- Place and pin using sight pins.



Other Parts

- M96 lower (M4 mag lower)
 - Base part, installation of gearbox and hopup is the same as above.

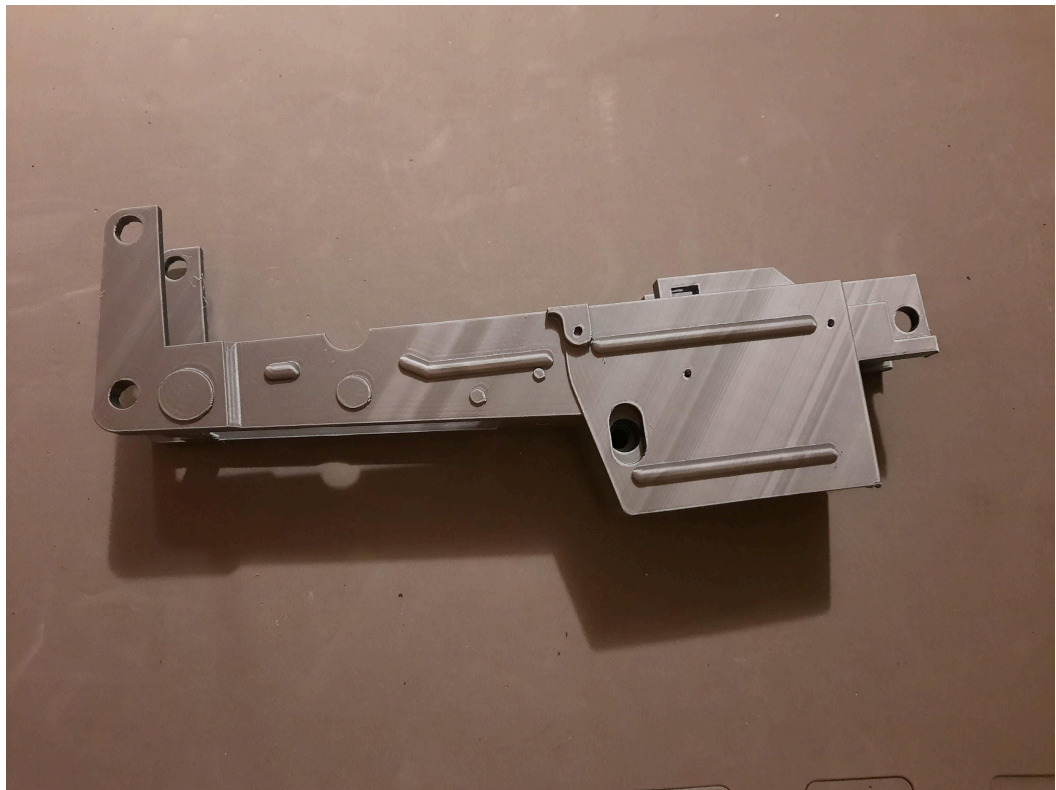

-
- The main difference is that the receiver has 2 pieces: the main lower, and the bb hose / tunnel / channel. Start by printing both, then insert the bb

hose into the lower through the mag well. Pin when in place with filament.

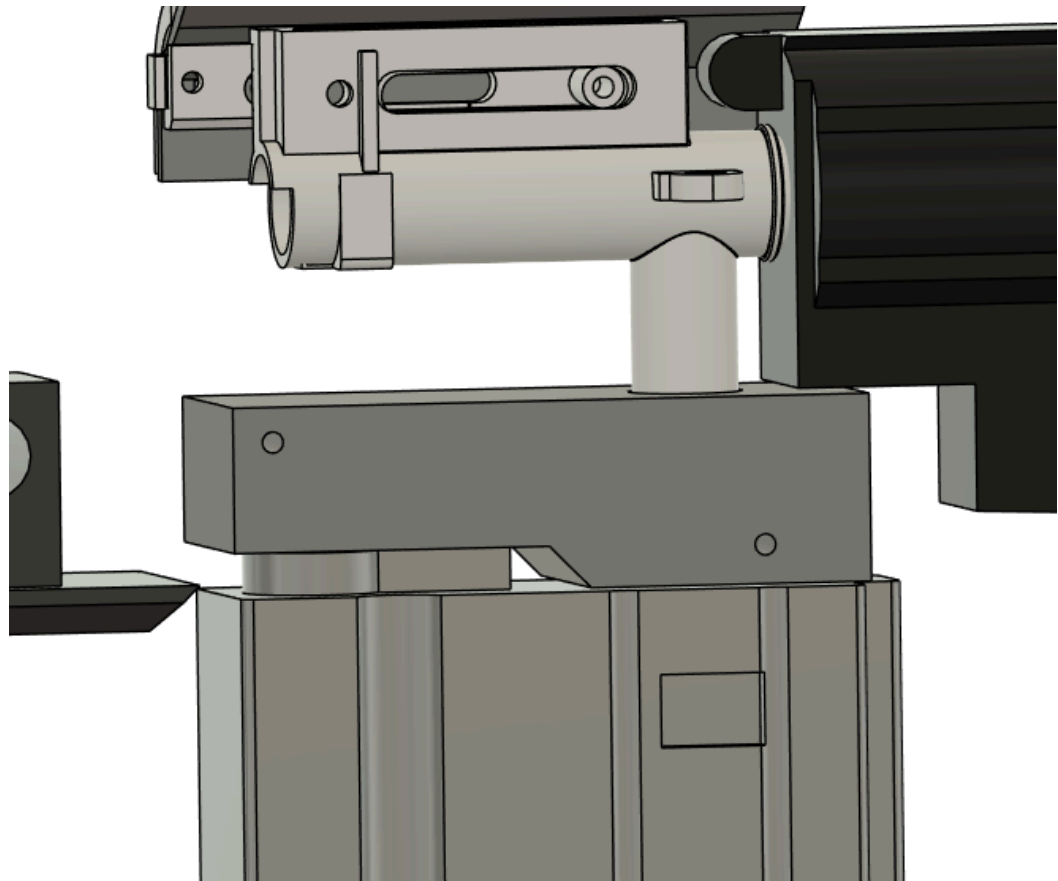

- Assemble catch as pictured, using filament as a pin.



- Instal Small Spring

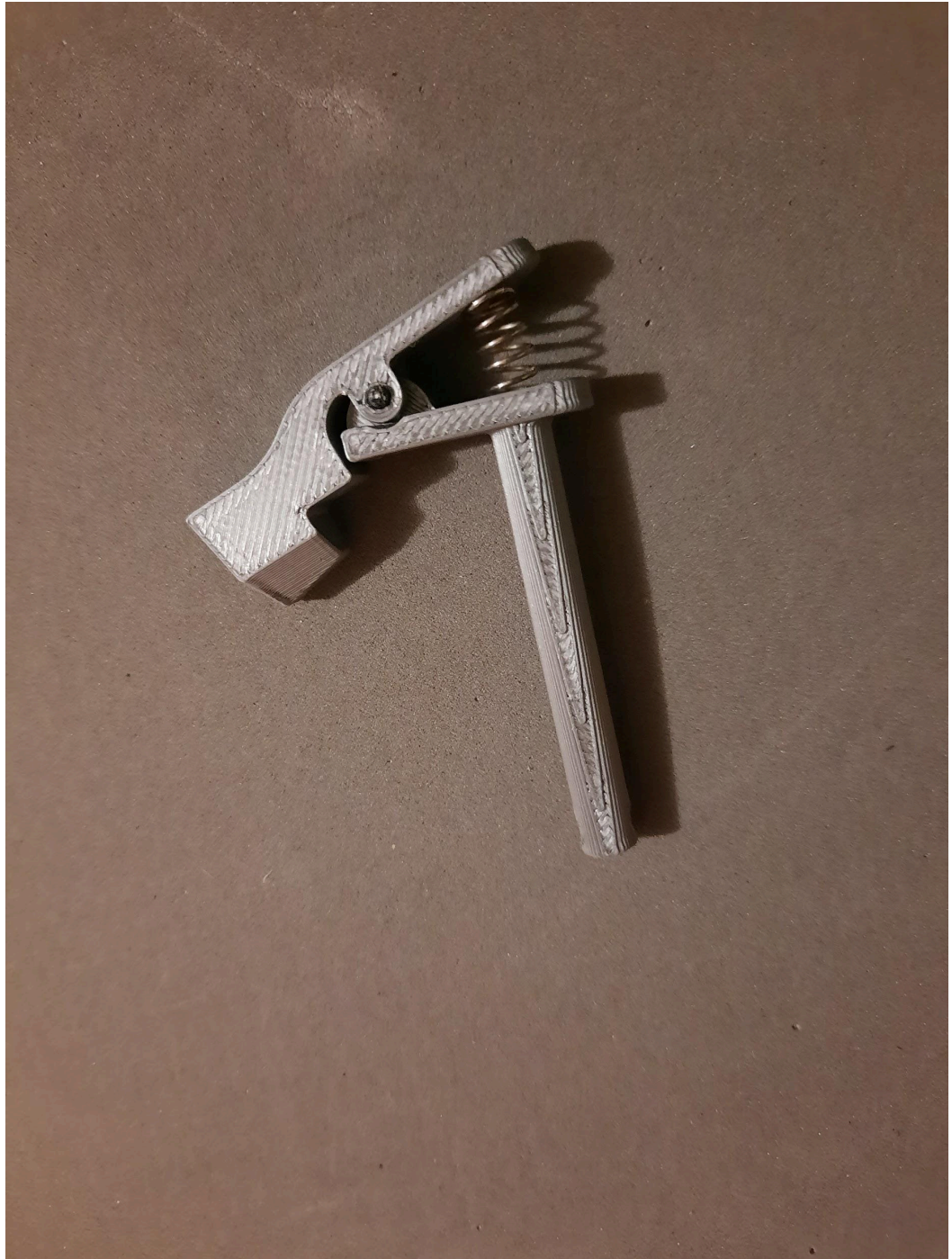

- Insert catch into receiver.

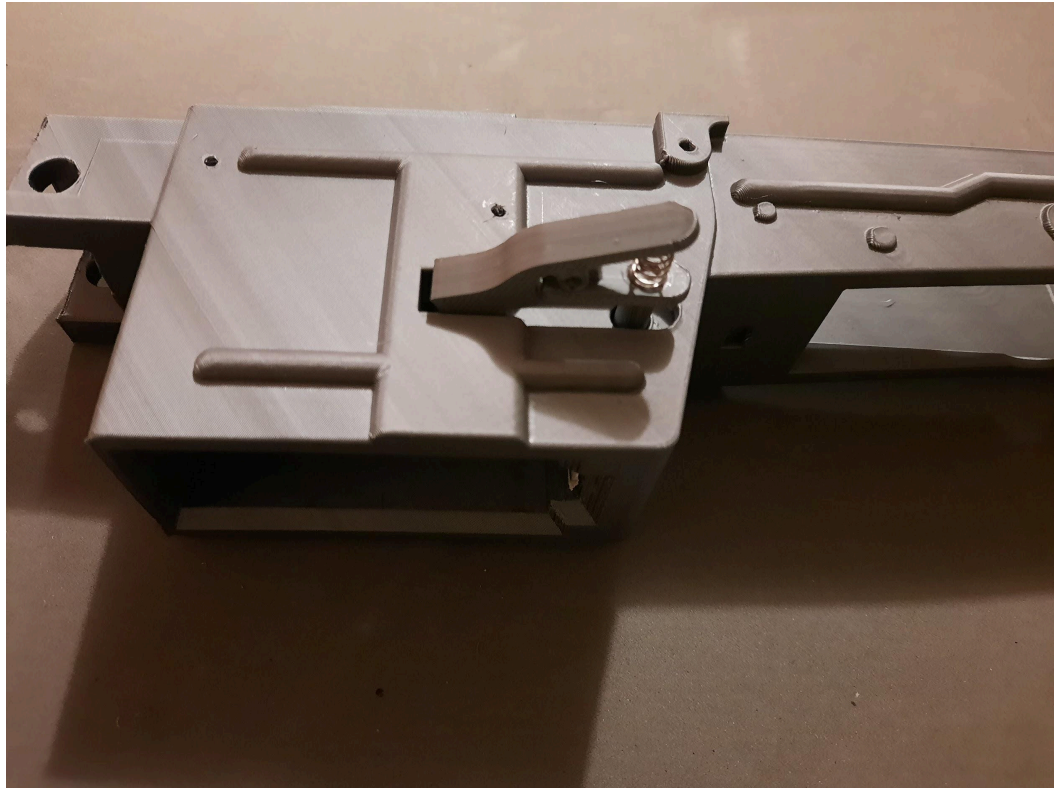

- Flip receiver over, install long spring and cap

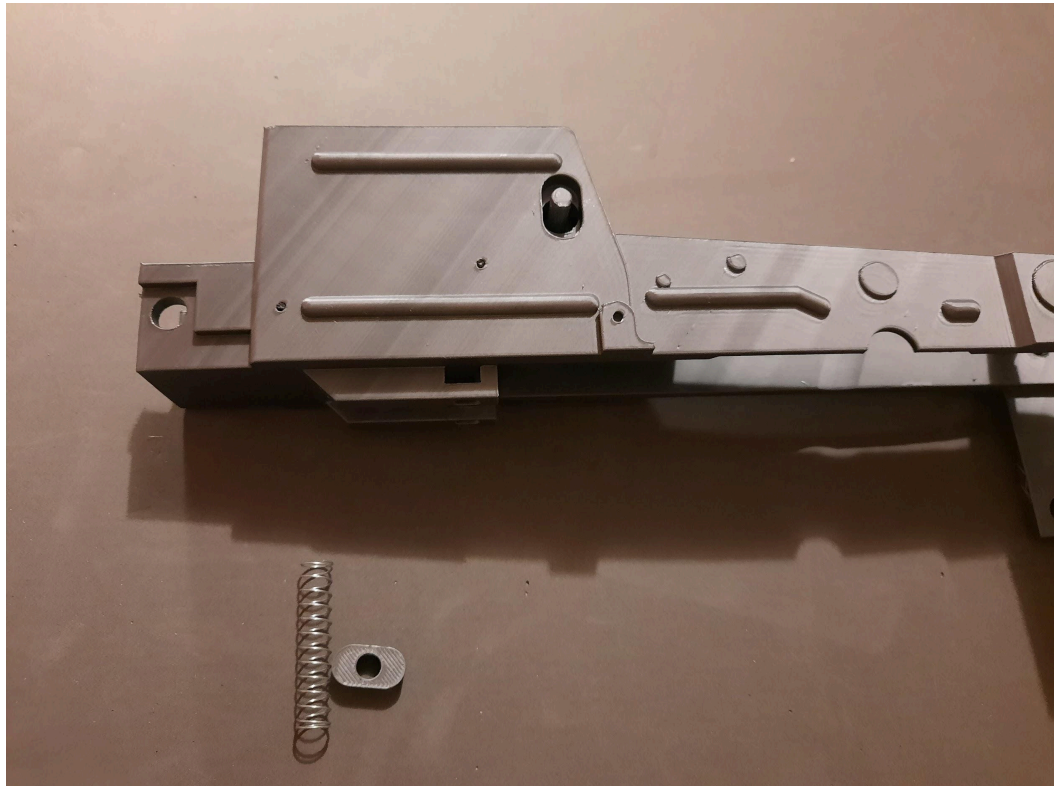

- Pin cap in place with filament.



- Test and inspect work.

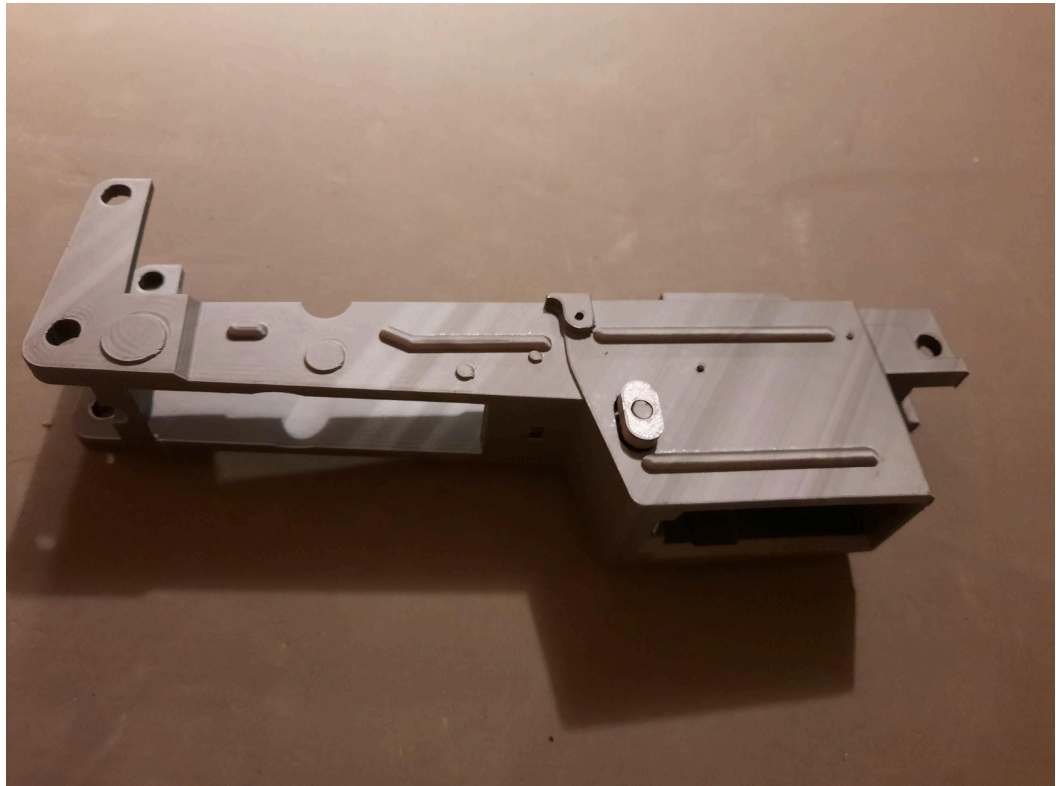

Conclusion

- Finished Build:

