



MOI HIGH SCHOOL KABARAK

TRAIL 1 2024

Kenya Certificate of Secondary Education

Name Adm. No. Class.....

232/2

**PHYSICS
(THEORY)**

2 hours

INSTRUCTIONS TO CANDIDATES

1. Write your name, index number, admission number and sign in the spaces provided above.
2. This paper consists of **two** sections **A** and **B**.
3. Answer **all** the questions in sections **A** and **B** in the spaces provided.
4. All workings **must** be clearly shown where applicable.
5. All numerical answers must be expressed in decimal form
6. Non-programmable silent electronic calculators and KNEC Mathematical tables may be used where applicable.

For Examiner's use only

Section	Questions	Maximum Score	Candidate's Score
A	1 – 12	25	
B	13	12	
	14	15	
	15	13	
	16	8	
	17	7	
TOTAL		80	

This paper consists of 12 printed pages. Candidates should check the question paper to ensure that all the pages are printed as indicated and no question is missing.

SECTION A (25 MARKS)

Answer ALL the question in this section in the spaces provided

1. The figure below represents a point image formed by a mirror.

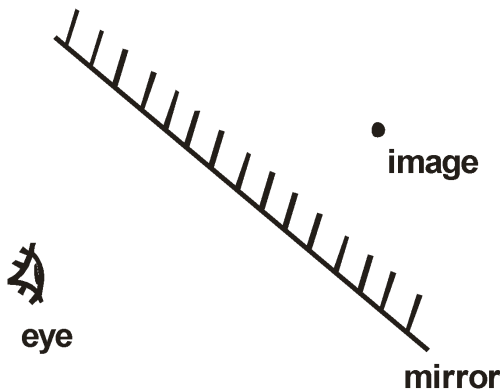

Sketch rays to show how the image is formed and seen by the eye. (2 mks)

2. State any **two** ways of increasing the size of an image formed by a pinhole camera. (2 mks)

.....

.....

3. A form one student was investigating the brightness of bulbs when set up in circuits. He used identical bulbs and cells.

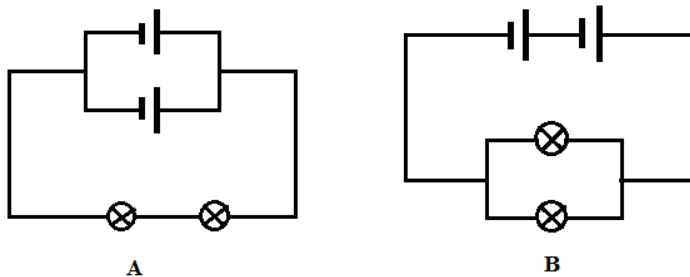

i. State which set up had the brightest bulb (1 marks)

.....

.....

ii. Explain the answer in (i) above. (1mk)

4. A lady holds a large concave mirror of focal length 1.8m from her face. State **two** characteristics of her image in the mirror (2mks)

.....
.....

5. The figure below shows two parallel thick copper conductors connected to a d.c power supply. A rider made from a thin copper wire is placed on the conductors as shown.

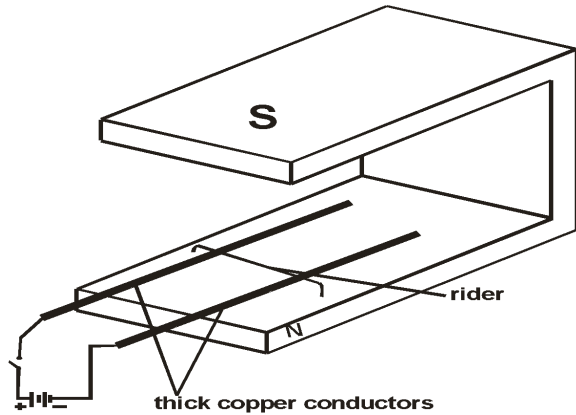

State and explain what is observed on the rider when the switch is closed. (2 mks)

.....
.....
.....

6. The figure below shows how the displacement varies with time for a certain wave.

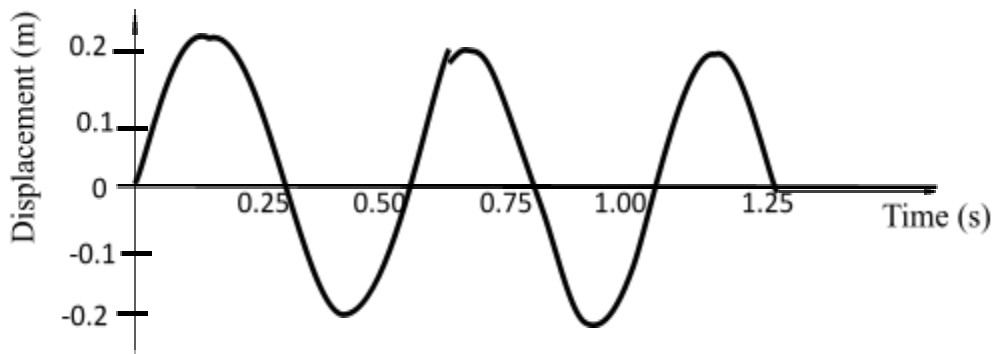

Determine the frequency of the wave. (3 mks)

7. Two pins are hanging from a magnet S shown in diagram below.

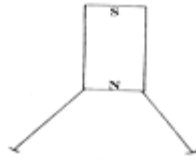

Explain why the nails do not hang vertically downwards.

(2mks)

.....

.....

.....

8. Draw diagrams to illustrate what happens when plane waves are incident on a slit. When the width of the slit is large compared with the wavelength of the waves. (2mks)

9. Determine the reading of the ammeter in figure below.

(2mks)

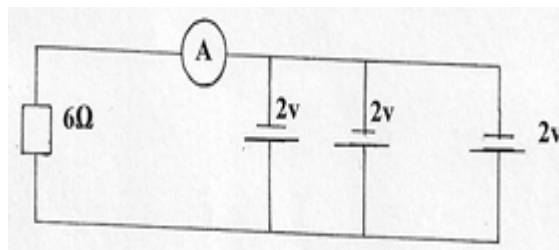

10. A ray of light is incident on a glass-oil interface as shown in fig. below. Determine the value of r . (Take refractive index of glass and oil as $\frac{3}{2}$ and $\frac{8}{5}$ respectively) (2mk)

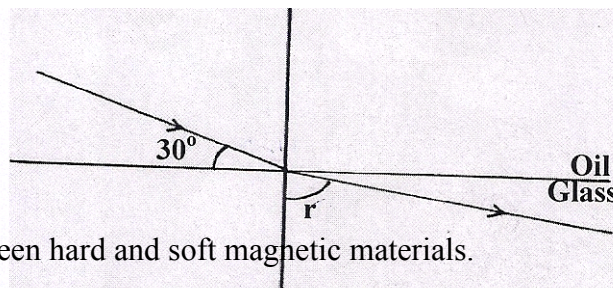

11. Distinguish between hard and soft magnetic materials.

(2 marks)

.....

.....

.....

12. An electric heater is found to have a resistance of 950Ω when operating normally on 240 V mains. Find the power rating of the heater. **(2 marks)**

.....
.....
.....
.....
.....

SECTION B (55 MARKS)

Answer ALL the questions in this section in the spaces provided

13. a) State one difference between light and sound waves (1 mk)

.....
.....
.....

- b) State two factors that affect speed of sound in solid. (2mks)

.....
.....
.....

- c) Explain how an increase in temperature affects the velocity of sound in air. (2 mks)

.....
.....
.....

- d) The figure below shows a set up made by a Form 2 student to study an aspect of a wave.

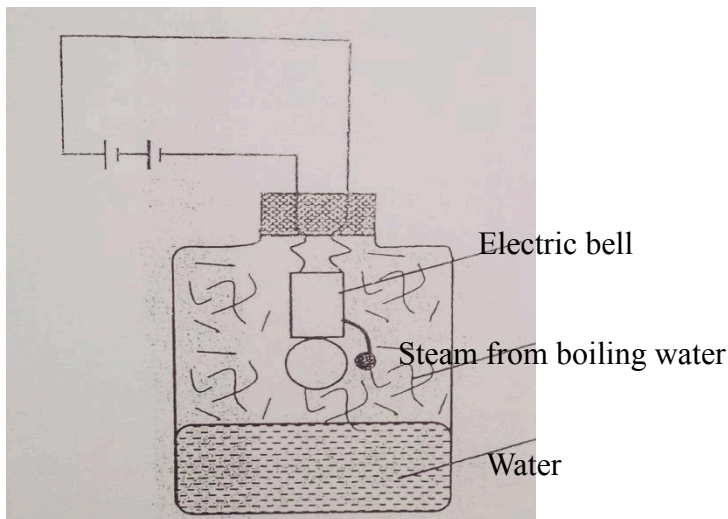

(i) State what happens to the sound from the bell as the bottle and its contents are cooled to 0°C
(1 mk)

(ii) Explain the observation in (i) above (2 mks)

.....
.....
.....

e) A boy stands some distance from a high wall and claps his hands. He claps again each time he hears an echo.

(i) What **two** measurements would need to be made in order to determine the speed of sound?
(2mks)

.....
.....

ii) The boy's friend notes that it takes 10 s to make 10 claps. Determine how far the boy is from the wall, given that the speed of sound in air is 330 m/s. (2 mks)

14. a) State Ohm's law. (1 mk)

.....
.....
.....

b) You are provided with connecting wires, ammeter, voltmeter, cells in a cell holder, variable resistor, switch and a conductor. With an aid of a diagram, describe an experiment to verify Ohm's law for a wire. (4 mks)

Procedure

.....
.....
.....
.....

c) (a) Study the circuit diagram below and answer the questions that follow.

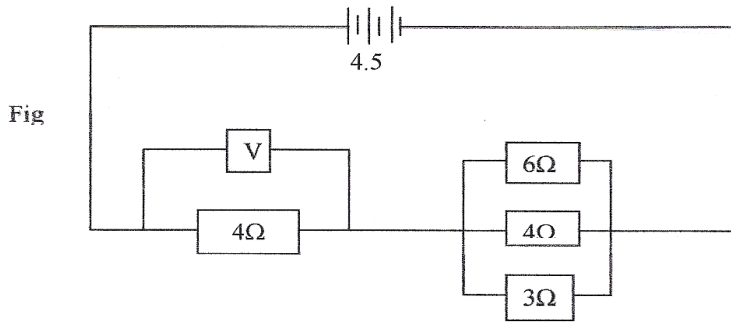

- (i) Calculate the effective resistance of the circuit. (3mks)
- (ii) Find the voltmeter reading. (3mks)

(b) c) The graph below shows the variation of potential difference V with current I for a certain cell.

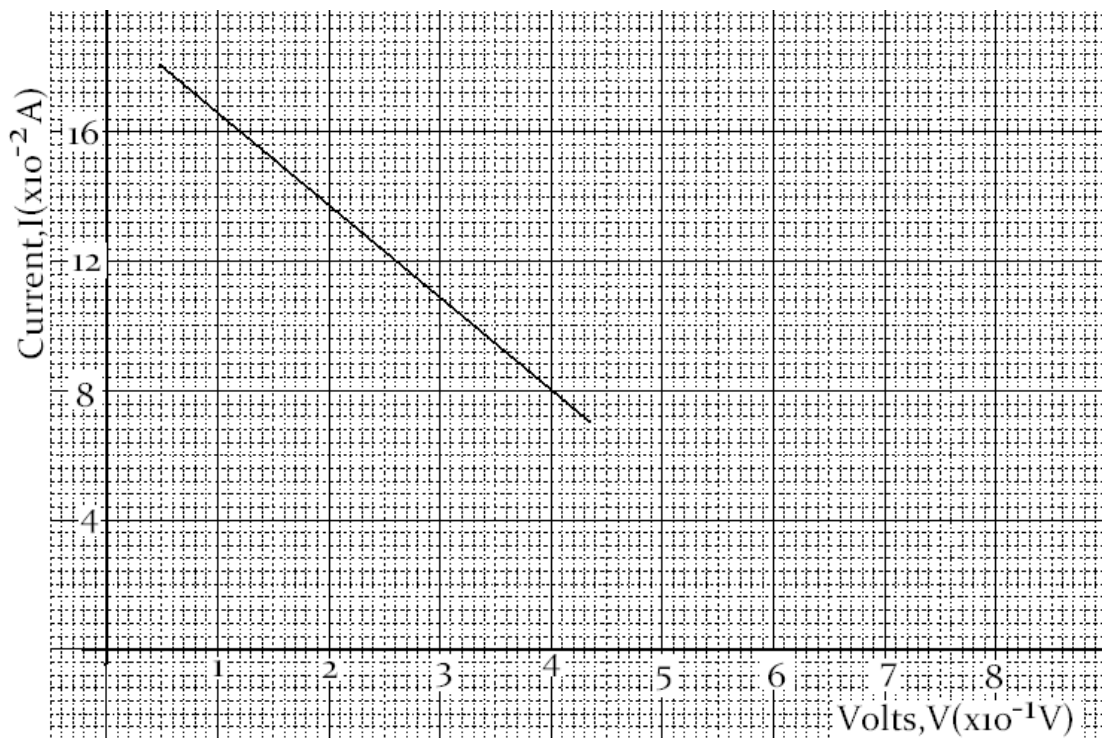

From the graph determine

- i). The internal resistance of the cell (3 marks)

.....

.....

.....

.....

- ii). The e.m.f of the cell (1 mark)

.....

 15. a) State **two** conditions necessary for total internal reflection to occur. (2 mks)

.....

 b) The figure below shows the part of a ray of yellow light through a glass prism. The speed of yellow light in the prism is 1.88×10^8 m/s.

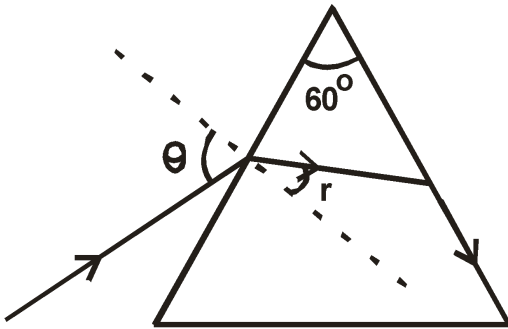

i) Determine the refractive index of the prism material (Speed of light in air, $C = 3.0 \times 10^8$ m/s) (2 mks)

ii) Show on the figure the critical angle **C**, and determine its value. (3 mks)

iii) Given that $r = 21.2^\circ$, determine angle θ . (2 mks)

c) The figure shows two rays A and B entering a semi-circular glass block which has a critical angle of 42° . The rays are incident at point O.

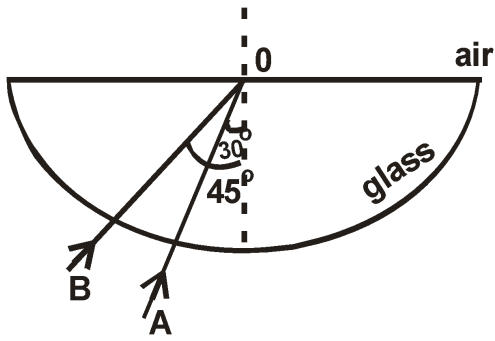

- (i) Complete the path of the two rays from point O. Label A^1 and B^1 the corresponding rays. (2 mks)
- (ii) Calculate the refractive index of the semicircular glass block. (2 mks)

16. a) define the term eclipse of the moon 1 mark

.....

.....

.....

.....

.....

b) differentiate between umbra and penumbra shadows. 2marks

.....

.....

.....

.....

.....

c) An incident ray forms an angle of 45 degrees with the mirror at point of incidence .If The position of the incident ray is kept constant while the mirror is rotated at an angle of 20 degrees .Find the angle through which the reflected ray is rotated 2 marks

d) A tree 25 m high stands, 50 m in front of a pinhole camera whose screen is 30 cm behind the pinhole. What is the height of the image of the tree formed on the screen. 3mks

17. a) Define capacitance of a capacitor (1mk)

.....
.....
.....

b) State two factors that affect the capacitance of a parallel-plate capacitor. (2mks)

.....
.....
.....

c. The figure below shows a voltmeter connected across two charged parallel plates.

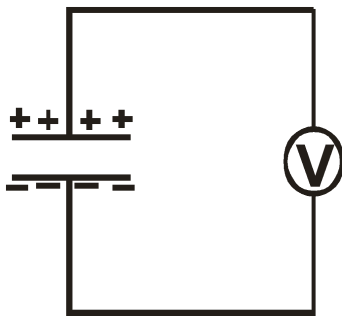

When a thin sheet of mica is inserted between the plates, the reading of the voltmeter is observed to reduce. Explain this observation. (2 mks)

.....
.....
.....
.....

d) Figure 2 below shows a positive charge near a plate carrying negative charge. Draw the electric field between them. (2mks)

Fig.2

