



## Technology Brief

# Automated Machine for Seed Fermentation

**Description:** A fermentation machine that can automatically monitor and control the fermentation process of a cacao seed bean at a preferred temperature.

**Innovative Features and Benefits:** One significant problem that the cocoa farmers encountered is not achieving the standard quality of postharvest products mainly due to the variation on the volume of the beans they fermented. This technology provides:

1. a system that **automatically monitors**, and
2. **controls** the preferred temperature by using artificial heat.

Thus, achieving a *well-fermented cacao seed bean*.

**Applications:** Fermentation is the critical process to produce a good quality of chocolate. It is essential to develop appropriate flavors from precursors and the stage where the flavor greatly enhances into the beans. Without the fermentation process, there will not be any chocolate flavor. Chocolate made from unfermented cocoa beans does not have the body and richness in comparison with chocolate made from fermented cocoa beans. The success of the fermentation process is a profit for both cacao farmers and the country's cacao industry. In response to this, the Automated Machine for Seed Fermentation can help to increase the productivity rate of cacao by improving the quality of seed fermentation process.

**Intellectual Property Status:** REGISTERED UM

Registration Number and Date: **2/2018/050551 2022.01.17**

**Business Development Opportunity:** Cocoa or Cacao (*Theobroma cacao*) is a vital product nowadays and offers a great earning source for smallholder farmers in the Philippines. According to the Department of Agriculture, the global demand for cacao is expected to reach between 4.7 Million to 5 Million metric tons by 2020, and statistics have shown that beans' global market grows annually by 2-3%. However, its production, in recent years, has been in decline. Faced with the increasing pressure to supply the world market, the cacao sector deals with complex economic, social, and environmental issues. At the same time, an increase in harvest does not automatically translate to a rise in income. Equally crucial to high-quality and amount of product is the postharvest product, mainly the *fermented bean*. For this very cause, this technology aims to resolve the trouble of temperature inconsistency of seed fermentation to bring about the excellent quality of a postharvest product, which gives an abundant supply and implies better and higher earnings for the farmers and the country's cacao industry.

The prototype has been developed and is ready for mass-scale production by a potential licensee.

**More Information:** Details of the technology can be further obtained from Kenneth L. Ciudad [klciudad@carsu.edu.ph; 09176785333]

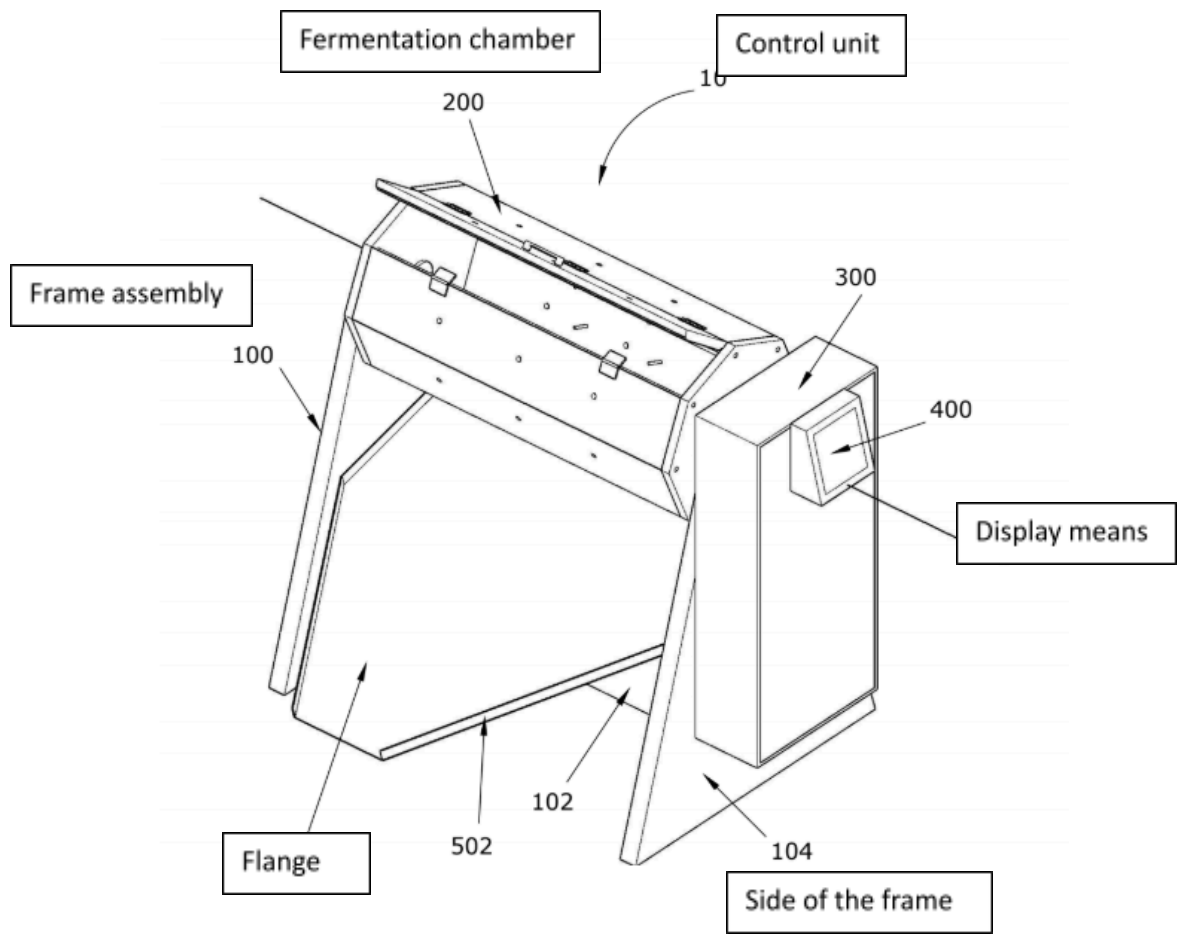

Figure: Isometric View of the Automated Machine for Seed Fermentation