

**TAMALE TECHNICAL UNIVERSITY**

**DEPARTMENT OF ELECTRICAL/ELECTRONIC ENGINEERING**



**RE-DESIGN AND CONSTRUCTION OF AUTOMATIC HOME BASED  
SECURITY LIGHTNING SYSTEM USING GSM**

**SARFO PAUL OPOKU JNR**

**ADAM ABDUL LATIF**

**SYLVESTER APAANE**

**2022**

**TAMALE TECHNICAL UNIVERSITY**

**DEPARTMENT OF ELECTRICAL AND ELECTRONIC ENGINEERING**

**RE-DESIGN AND CONSTRUCTION OF AUTOMATIC HOME BASED  
SECURITY LIGHTNING SYSTEM USING GSM**

**BY**

**NAMES**

**MATRIC NUMBERS**

**SARFO PAUL OPOKU JNR**

**08190501**

**ADAM ABDUL LATIF**

**08180381**

**SYLVESTER APAANE**

**08190509**

**A PROJECT WORK SUBMITTED TO THE DEPARTMENT OF ELECTRICAL/  
ELECTRONIC ENGINEERING, TAMALE TECHNICAL UNIVERITY IN PARTIAL  
FULFILLMENT OF THE REQUIREMENTS FOR THE AWARD OF HIGHER  
NATIONAL DIPLOMA IN ELECTRICALS.**

**NOVEMBER, 2022**

## *Contents*

Candidates' Declaration .....	iv
Certification .....	iv
ABSTRACT .....	v
ACKNOWLEDGMENT .....	vi
DEDICATION.....	vii
CHAPTER ONE .....	1
INTRODUCTION .....	1
1.0 Background of the study .....	1
1.1 Statement of the Problem.....	2
1.2 Purpose of the study .....	3
1.3 Specific Objectives.....	4
1.4 Significance of Study .....	4
1.5 Delimitation.....	5
1.6 Limitations .....	5
CHAPTER TWO .....	6
2.0 REVIEW OF RELATED LITERATURE .....	6
2.1 Background review .....	6
2.2. EARLY MACHINES TO BE OPERATED BY REMOTE CONTROL.....	6
2.2.1 Flash-Matic.....	7
2.3 HOME AUTOMATION SYSTEM.....	8
2.3.1 Mobile-web technology and the rural people.....	9
2.4 TONE RECOGNITION DEVICE.....	9
2.5 HISTORY OF HOME AUTOMATION .....	10
2.5.1 The mechanical evolution of home automation.....	11
2.5.2 Automation energy source.....	12
2.5.3 The information revolution .....	12
2.6 SMART HOME TODAY .....	13
2.6.1 The Xanadu smart home.....	14

2.6.2 Automatic speed recognition (ASR) device.....	14
2.6.2.1 A signal processing front-end.....	15
2.6.2.2 Acoustic modelling.....	16
2.6.2.3 Language modelling.....	16
2.6.3 Mode of transmission of signal information.....	16
2.6.4 Subscriber identity module (SIM) as a GSM feature.....	17
2.7 RESEARCH GAP.....	18
CHAPTER THREE .....	19
RESEARCH METHODOLOGY.....	19
3.0 Introduction .....	19
3.1 Hardware subsystems.....	19
Block diagram.....	20
3.2 System design and analysis .....	21
3.3 Circuit diagram.....	22
3.4 System flowchart.....	23
3.5 Description of components.....	24
Arduino UNO .....	25
GSM SIM 900 Module .....	26
Relay modules .....	29
Modem.....	30
Power supply .....	31
LED.....	31
Resistor.....	32
Software and tool used.....	33
Program code.....	34
CHAPTER FOUR .....	41

4.1 Choice of development tools.....	41
4.2 System requirement .....	41
4.2.1 Software requirement.....	41
4.4.2 System hardware requirement.....	41
4.3 Steps to construction of GSM home based security lightning system.....	42
4.3.1 Design of the system block diagram.....	42
4.3.2 Inspection and preparation of the vero board.....	42
4.3.3 Mounting of the components.....	44
4.3.4 Interconnection of components.....	44
4.4 Implementation of the project.....	45
4.5 Testing.....	46
4.5.1 Testing of the individual components.....	46
4.5.2 Unit by unit testing.....	46
4.5.3 System testing.....	47
4.6 Packaging.....	47
4.7 Bill of materials and evaluation .....	48
CHAPTER FIVE .....	50
5.0 SUMMARY, MAIN FINDINGS AND RECOMMEDATIONS.....	50
5.1 Summary .....	50
5.2 Major constraints of the project.....	50
5.3 Constraints considerations.....	51
5.4 Technology considerations.....	51
Recommendations.....	52
Conclusion.....	52
REFERENCES .....	53

**Candidates' Declaration**

We hereby declare that this project work is the results our own original work and that no part of it has been submitted for another programmer in the School of Engineering and, Tamale Technical University, or elsewhere.

**Student Name:**

**SARFO PAUL OPOKU JNR**

**08190501**

Signature:.....

Date.....

**ADAM ABDUL LATIF**

**08180381**

Signature:.....

Date.....

**SYLVESTER APAANE**

**08190509**

Signature:.....

Date.....

**Certification**

We hereby certify that the preparation and presentation of this project work were supervised in accordance with the guidelines on project work laid down by the School of Engineering, Tamale Technical University.

**INTERNAL SUPERVISOR: MR. HENRY KWAME ATIGLAH**

Signature:..... Date: .....

**HEAD OF DEPARTMENT: ALHAJI ABUKARI ISSAHAKU**

Signature: ..... Date: .....

## **ABSTRACT**

This project aims at the design and construction of a security lighting control system using a mobile phone to serve as a remote control to control security lights. The device is made up of four main units. The mobile phone which is serving as a transmitter for remotely controlling the security lights. The GSM modem which serves as the receiver. A SIM card is placed in the GSM modem and all messages from the transmitter are sent to that mobile number. The microcontroller unit processes the information extracts the message from the GSM modem and processes it. Then it either puts on a pin or leaves it off. The switching unit is responsible for putting on or off the bulb depending on the output from the microcontroller. Upon completion of the project, it was tested and it worked properly. "ON" puts on the bulb, "OFF" puts off the bulb and "STATE" reads the condition of the bulb. Thus an effective and reliable security lighting control system using mobile phone was realized.

## **ACKNOWLEDGEMENT**

Our special gratitude goes to Mr. HENRY KWAME ATIGLAH our supervisor for his impeccable suggestions and critical insights which helped shape this project work and made it a successful one.

We are also ginormously grateful to Mr. STEPHEN NUANGAH for his patience, hardwork, dedication and the help he has rendered us. Our gratitude goes to our parents, friends and entire family members for their support and encouragement given to us during our time in the university. We also want to extend our appreciation to members of the School of Engineering for furnishing us with the necessary information needed for the research work. Special thanks goes to all those who contributed in diverse ways to making this work a success. Finally, while many people have been acknowledged for helping us in this project, we remain responsible for all errors, shortcoming and views expressed in this work.

## **DEDICATION**

We dedicate this project work to the Lord of the entire universe and beyond, our families, our colleagues, staff and faculty of the electrical/electronic engineering department, loved ones and all those who help us in the course of our studies in Tamale Technical University.

## CHAPTER ONE

### 1.0 BACKGROUND OF STUDY

Smart Home also known as Automated Home or intelligent home which indicates the automation of daily tasks with electrical appliances used in homes. This could be the control of lights, fans, viewing of the house interiors for surveillance purposes or giving the alarm alteration or indication in case of gas leakage. One of the reasons for the rise of the smart home is the increasing risk of burglary and robbery and the busy lifestyle of people is leading to the necessity of controlling the devices at home remotely and increasing the necessity of keeping surveillance over their homes.

The goal of the project is to implement a smart home system by controlling the electronic devices at home remotely with the help of a mobile device and getting alerts on intrusion or movement around the restricted premises.

Arduino-Uno Board are used to communicate between the mobile phone and the devices and sensors installed at home. The mobile phone can be used as a controller from anywhere in the world if the GSM network is available.

In the scope of industrialization, automation is a step beyond mechanization. Whereas mechanization provided human operators with machinery to assist them with the muscular requirement of work, automation greatly decreases the need for human sensory and mental requirements as well. Automation plays an increasing important role in the world economy and in daily experience. Automatic systems are being preferred over manual systems. The advancement of technology has increased the safety and security of people along with their belongings.

With the help of the GSM network, a mobile can be used to implement a smart home by controlling devices and getting alerts on robbery and burglary.

## **1.1 STATEMENT OF PROBLEM**

The most common problem that home owners encounter in relation to lighting system is due to some negligence like leaving the lights ON in error resulting to greater power consumption. This wastes power, hence higher bills.

Crime rates in Tamale, Ghana and in different parts of the world is a huge problem, and as such home and personal security threats are something that people experience on a daily basis.

Another problem is that of the busy home owners who will arrive home late at night; they may want to switch on their security lights from a distance in order to protect their house against robbery and crimes.

These facts prove that the installation of a home security system (security lights) dissuades intruders and protects your home. Thus, having a smart home system may decrease the chances of a burglary.

## **1.2 PURPOSE OF STUDY**

Nowadays, people's expectations in technology is improving rapidly. People need an affordable system (smart) that can make their lives easier, more comfortable, and offer more safety. GSM based home automation system is an electrical/electronic system designed to control home appliance with a mobile phone.

The busy lifestyle of people is leading to the necessity of controlling the devices at home remotely and increasing the necessity of keeping surveillance over their homes. It's now possible for users to control and monitor systems and development in their household with the help of their smartphones.

Home owners who stay late at work and are also distant from their homes often have challenges of putting on their security lights from wherever they will be, and also be able to on the light on time due to this they are most likely to experience burglary in their homes. This project consist of a GSM modem and a mobile phone which will serve as a remote control to put ON or OFF security lights at homes from a distance and at the desired time thereby alleviating the possibility of theft and also reduce consumption of security lights since they can be controlled from a distance.

### **1.3 OBJECTIVES OF RE-DESIGN AND CONSTRUCTION OF AUTOMATIC HOME BASED SECURITY LIGHTNING SYSTEM USING GSM**

The general objectives of the project are defined as;

1. Design of an automatic home based security lightning system using GSM.
2. Construction of an automatic home based security lightning using GSM.
3. Analyze the operation of the automatic security lightning system.

#### **1.4 SIGNIFICANCE OF STUDY**

The project is specially designed for busy home owners to allow them to put ON and OFF their security lightning from wherever they maybe thereby reducing the rate of burglary, and making life easier since they don't need to fret about putting on and off their security lights from a distance. Also, the project will help reduce the rate of energy consumption that would be caused due to the negligence of leaving the lights on.

#### **1.5 DELIMITATIONS**

This study is limited to:

1. Security lights in a home.

2. GSM network.
3. Arduino-Uno

## **1.6 LIMITATIONS OF PROJECT**

This project has certain limitations and a list of such is mentioned below;

1. The receiver must reside in a location where a signal with sufficient strength can be received from a cellular phone network (GSM availability)
2. Only devices with electrical controlling input ports will be possible targets for control.
3. Operation of the controlling unit is only possible through a cell phone and SIM card with the capability of receiving messages

## **CHAPTER TWO**

### **2.0 LITERATURE REVIEW**

Literature review is a comprehensive summary of previous research on a topic. The literature review surveys scholarly articles, books, and other sources relevant to a particular area of research. The review should enumerate, describe, summarize, objectively evaluate and clarify this previous research. It should give a theoretical base for the research and help you (the author) determine the nature of your research. The literature review acknowledges the work of previous researchers, it is assumed that by mentioning a previous work in the field of study, that the author has read, evaluated, and assimilated that work into the work at hand.

#### **2.1 Background Review**

For many years now, a lot of people have worked on home automation. Home automation can be described as introduction of technology within the home environment to provide convenience, comfort, security and energy saving to its occupants. Adding intelligence to home environment can provide increased quality of life for the elderly and disabled people who might otherwise require care givers or institutional care. There has been a significant increase in home automation in recent years due to higher affordability and advancement in phones (Y. Liu, 2013). Various works have been carried out with the use of microcontrollers to design Home Automation.

## **2.2 Early Machines To Be Operated By Remote Control**

The first machines to be operated by remote control were used mainly for military purposes. Radio controlled motorboats, developed by the German navy were used to ram enemy ships in World War I. Radio controlled bombs and other remote control weapons were used in World War II. Once the wars were over, United States scientists experimented to find non-military uses for the remote control. In the late 1940's automatic garage door openers were invented, and in the 1950's the first TV remote controls were used. Zenith began playing around with the idea of a TV Remote control in the early 1950's. The first TV remote control, called the "Lazy Bones," was developed in 1950 by Zenith (then known as Zenith Radio Corporation and now a wholly owned subsidiary of LG Electronics USA). The Lazy Bones used a cable that ran from the TV set to the viewer. A motor in the TV set operated the tuner through the remote control. By pushing buttons on the remote control, viewers rotated the tuner clockwise or counterclockwise, depending on whether they wanted to change the channel to a higher or lower number. The remote control included buttons that turned the TV on and off. This type of remote wasn't popular for long considering that, at the time, there were very few channels to choose from.

### **2.2.1 Flash-matic**

Zenith engineer Eugene J. Polley invented the "Flash-Matic," which represented the industry's first wireless TV remote. Introduced in 1955, Flash-Matic operated by means of four photo cells, one in each corner of the TV screen. The viewer used a highly directional flashlight to activate the four control functions, which turned the picture and sound on and off and changed channels by turning the tuner dial clockwise and counter-clockwise. Flash-Matic pioneered the concept of wireless TV remote control,

although it had some limitations. It was a simple device that had no protection circuits and, if the TV sat in an area in which the sun shone directly on it, the tuner might start rotating (Zenith electronics, LLC, 2019). However, people often forgot which corner of the TV operated which control. Manufacturers used to only make remote controls that operated one TV set. However, they've recently begun making universal remote controls that can operate any TV set. Expert predicts that someday remote controls will control almost every device in the home. R.C. Goertz developed a mechanical manipulator in 1948 to aid in radioactive lab work. The machine can be thought of as two distinct devices, the "slave" and "master" arms. The "slave" arm is responsive to the controlling device, the "master" arm, with the benefit that through remote handling manual tasks can be performed without the need of direct human intervention. In nuclear settings the slave arm is located within a hot-cell and the master arm is located in a control room. Whenever the master arm is manipulated, the motion is reproduced precisely by the slave arm (Singh, Manjit, 2006). In 1954 an electric machine was made to replace Goertz's machine, which was operated by cables. Since '54 better design has been developed, but the electric manipulator remains relatively unchanged to this day.

Here, some research such as Home Automation system and its application, Tone recognition devices, Automatic Speech recognition, the technical detail of GSM will be looked into as they relate to remote control systems.

## **2.3 Home Automation System**

Home automation is the automatic control of electronic devices home. These devices are connected to the Internet, which allows the devices to be controlled remotely. With home automation, devices can trigger one another so you don't have to control them manually via an app or voice assistant. A smart home's devices are connected with each other and can be accessed through one central point—a smartphone, tablet, laptop, or game console. Door locks, televisions, thermostats, home monitors, cameras, lights, and even appliances such as the refrigerator can be controlled through one home automation system. The system is installed on a mobile or other networked device, and the user can create time schedules for certain changes to take effect.

Automation is, unsurprisingly, one of the two main characteristics of home automation. Automation refers to the ability to program and schedule events for the devices on the network. The programming may include time-related commands, such as having your lights turn on or off at specific times each day. It can also include non-scheduled events, such as turning on all the lights in your home when your security system alarm is triggered.

Furthermore, the possible solutions are devices through various network technologies. Several issues affecting home automation systems such as lack of robustness, compatibility issue and acceptability among the old and disabled people are discussed. (Ciubotaru-Petrescu, et al., 2006) present a design and implementation of SMS based control for monitoring systems. The paper has three modules involving sensing unit for monitoring the complex applications, a processing unit: microcontroller and a communication module that uses GPRS modem or cell phone via serial port RS-232 and the SMS is used for status reporting such as power failure, (Scaradozzi et al., 2003). In their paper, home automation systems are viewed as multiple agent systems (MAS). In the paper, home automation system has been proposed and this includes home appliances and devices that are controlled and maintained for home management. The major task is to improve performance. In their paper, (Alkar and Buhur 2005) propose an internet based wireless home automation system for multifunctional devices.

### **2.3.1 Mobile Web Technology And The Rural People**

Murthy (2008) explores primary health-care (PHC) management for the rural population. A solution proposes the use of the mobile web-technologies providing the PHC services to the rural population. The system involves the use of SMS and cell phone technology for information management, transactional exchange and personal communication. (Jawarkar, et al., 2008) propose remote monitoring through mobile phone involving the use of spoken commands. In this system the spoken commands are generated and sent in the form of text SMS to the control system and then the microcontroller on the basis of SMS takes a decision of a particular task. (Potamitis, et al., 2003) suggest the use of speech to interact remotely with the home appliances to perform a particular action on behalf of the user. The

approach is inclined for people with disability to perform real- life operations at home by directing appliances through speech. Voice separation strategy is selected to take appropriate decision by speech recognition.

## **2.4 Tone Recognition Device**

Voice or tone recognition is the ability of a machine or program to receive and interpret dictation or to understand and carry out spoken commands. Voice recognition has gained prominence and use with the rise of AI and intelligent assistants, such as Amazon's Alexa, Apple's Siri and Microsoft's Cortana.

Voice recognition systems enable consumers to interact with technology simply by speaking to it, enabling hands-free requests, reminders and other simple tasks. (Jesse Scardina, 2019).

Despite the fact that the largest stride in the development of tone recognition devices has occurred in the past two decades, this aspect of technology really began with Alexander Graham bell's invention at about 1870. In his discovery, conversion of sound waves into electrical signals started the process of exploring scientific and mathematical basis for understanding bell laboratories in the 50's developed the first effective tone recognition for numbers. The American Research Project Agency (ARPA) after various researches on speech understanding developed the technology further focusing particularly on the fact that the objective of automatic tone recognition is the understanding of speech not merely words (Jacqueline Boytim, 2013). By the 80's distinct types of products were available, they offered speaker independent recognition systems such that document could be created by voice dictation. The last two decades has invariably a development of voice recognition to the point of real-time continuous speech systems with exceptional high accuracy.

## **2.5 History of Home Automation**

Home automation refers to the automatic and electronic control of household features, activity, and appliances. In simple terms, it means you can easily control the utilities and

features of your home via the Internet to make life more convenient and secure, and even spend less on household bills.

Home automation gives you access to control devices in your home from a mobile device anywhere in the world. The term may be used for isolated programmable devices, like smart thermostats and sprinkler systems, but home automation more accurately describes homes in which nearly everything—smart light switches, appliances, smart outlets, heating and cooling systems—hook up to a remotely controllable network.

Although the term “home automation” was first used in 1980s, the concept is far from new. The early documented attempt to envisage something very similar dates back to the 1960s, with Walt Disney’s Experimental Prototype Community of Tomorrow (EPCOT), presented in 1966. A smart home will not be able to accomplish much without appliances to control, nor will it be able to communicate to these devices in the absence of a control network (“home network”). Since appliances and home network are so interlinked with a smart home, the following sections provide a brief history on how these come into being.

### **2.5.1 The Mechanical Evolution of Home Automation**

The technology of automation has evolved from the related field of mechanization, which had its beginnings in the Industrial Revolution. Mechanization refers to the replacement of human (or animal) power with mechanical power of some form. The driving force behind mechanization has been humankind’s propensity to create tools and mechanical devices. In late 1800’s, the middle class was experiencing a shortage of domestic servants which created the need to find new ways to provide help in the home (Harper, 2003). Such necessity was the initial driving force behind the inventions of the first domestic appliances, which had the purpose of making household chores easier and do more with less.

In 1911, Frederick Winslow Taylor published “The Principles of Scientific Management”, which advocated the use of efficiency to maximize results through minimal effort. This theory is today known as Taylorism and, though it was originally intended to be applied in industrial settings, this concept soon spilled over into the domestic realm due to the need at

hand. 1911, Christine Frederick was one of the first to recognize that the challenges tackled by Taylorism were also directly applicable to domestic issues and captured these in her book “Household engineering: Scientific Management in the Home”, published in 1915. In her book, Frederick predicts that mechanical appliances would be the ones which were to take up the work originally performed by servants “where every possible purely manual task is done by arms of steel and knuckles of copper”. She also puts forward the idea of a Smart Home where she foretells that “such machinery will be far more unified than at present with various pieces related to one another”, as reported by D. Heckman (2008).

### **2.5.2 Automation Energy Source**

In spite of the first inventions, most of this new domestic technology would have still been easily recognized by people who had lived in the previous Century. However, electricity, the driving force behind the electrical revolution, would soon change this familiar landscape beyond recognition. Electrical energy first arrived in the homes around 1920s but were initially used for lightning purposes only. By 1940s, mains electricity was readily available to around 65 per cent of the total of houses in the UK. (Harper, 2003). Soon after it reached a critical mass, producers of electrical appliances inundated the market with all sorts of items. Although some of them were nice-to-have-devices, such as electric popcorns poppers, egg cookers and waffle irons, others were really life changing for the household: refrigerators, washing machines, electric cookers, vacuum cleaners, just to mention the most important. Regardless of their importance, all these electrical appliances were still made with the original need in mind which was often reminded to people as producers marketed these products with time-saving slogans such as “no longer tied down by housework” or “automatically gives you time to do those things you want to do” (Heckman, 2008). It is interesting to note how some later devices could be hardly classified as time savers and how, in spite of this, they were still quite readily adopted. By early 1980s, around 65 per cent of UK homes had a colour television set and half of them a video recorder (Harper, 2003). More interesting still, the adoption curve was different from one to another, sometimes regardless of the comfort that they could bring.

### **2.5.3 The Information Revolution**

Disney's original vision for EPCOT was to create both a laboratory for new technology and a home for its inhabitants with the promise of offering an "integrated living environment" (Heckman, 2008). Due to his untimely death, just a few months after the official presentation of the project, EPCOT was never implemented, at least not in its original idea. The concept behind the original vision was however to live on. In the 1960s, a number of hardware and software innovations made possible for home owners to have access to the first computer like appliances in their homes. Perhaps the first attempt to create a "home automation" system occurred in 1966 when Westinghouse proposed the experimental and quite bulky Electronic Computing Home Operator (ECHO IV). Although the original system was supposed to automate the family finances, it was soon extended to include recipes, shopping lists, family inventory, and, in its final versions, added home temperature control and the ability to control appliances.

In 1975, it was the turn of the Altair 8800, followed by the Apple II in 1977 and the IBM PC in 1981 (Rojas Raúl, 2001). While these computers were slowly finding their ways into the home, they also contributed to the creation of the idea of "smart machines". In 1978, after a few years of experimentation and refinement, PICO Electronics patented the X10 technology. This technology can be considered the first "home network" as, differently to other networks available at the time, it enabled the existing electrical wiring in anyone's home to also be used as the media for the communication network. By doing so, X10 made home automation a reality for the majority of the household at an affordable price. Nowadays, an increasing number of houses have home computers, game consoles and always-on Internet connections that extend the availability of services and resources to the household beyond the physical boundaries of the home.

## **2.6 Smart Home Today**

The Oxford Dictionary defines "smart" as both "stylish and fresh in appearance, having a quick intelligence", and "being fashionable and up market". Sony was among the first companies to attach the "Smart" buzzword to a computer when, in 1982, it marketed the

“Smart Sony” computer: no longer advertised simply as a “home” computer, but tried to cash in on the smart concept by selling it as a device which could “help you make smarter business decisions” (Heckman, 2008). The “smart” concept has since become a marketing catchword, still employed today, to sell a wide range of products, hence: “Smart phones”, “smart cameras”, “smart design”, “smart bombs” and “smart homes”. Usually, the word define devices that are reportedly based on cutting-edge design that unite innovation with practical simplicity, However, as this would soon be demonstrated, sometimes marketing buzzwords alone cannot guarantee the sell. Xanadu was the first example of a mass-produced Smart Home. Built throughout the 1980s in the US around the original EPCOT idea, these houses were commercially built dwellings that made extensive use of Smart Home technologies. To look even more futuristic, the actual house was made entirely of polyurethane foam.

### **2.6.1 The Xanadu Smart Home**

The Xanadu home had a computer that monitored and controlled all its systems: the kitchen, living room, bathrooms, and bedrooms all had their own electrical and electronic devices to control the appliances present in the house. For example, the shower could be set to be turned on at a specific time and a set temperature. The advertisement campaign eloquently described the house as “Xanadu: the Computerized House of Tomorrow” and its peculiar appeal was set by the advertisement campaign: a “house with a brain – a house you can talk to, a house where every room adjusts automatically to match your changing moods” (Heckman, 2008). As the time moved on, and most of the houses were still unsold, the technology contained soon became obsolete. One by one, these Xanadu houses started to get demolished to make space for more “commercially viable” projects and, by October 2005, they were all gone. In spite of the commercial setback provided by the Xanadu homes, the concept was sound and a combination of elements such as computers, robotics and Artificial Intelligence (AI) were to push the Smart Home concept further, even if sometimes only in research laboratories. Throughout the 1980s, several innovative ideas provided a clear indication that the technology might have been finally mature enough to deliver commercially viable solutions. As an example, a device named Waldo, which

interfaced with an Apple computer, could use voice recognition and speech synthesis technology to control appliances.

## **2.6.2 Automatic Speech Recognition (ASR) Device**

Automatic speech recognition (ASR) is the process by which a computer maps an acoustic speech signal to some form of abstract meaning of the speech. Automatic speech recognition (ASR) applications focus on public services such as operator automatic operator assistance voice activated information retrieval, voice doing and many other similar tasks. Speech recognition should not be confused with a dial tone (DTMF) application where the user must select from numbered options or spell out and account number using the telephone keypad. A speech recognition application allows the user to answer questions and provide information using a normal speaking voice many companies have already invested easily in human powered call centres or DTMF (touch- tone) interactive voice response (IVR) systems. They are changing or adapting to ASR applications, because of cost savings and improvement in customer satisfaction and experience. It has been shown that automatic speech recognition application are far more popular with callers than DTMF menu systems. In general, ASR system consist of

### **2.6.2.1 A signal processing front-end**

The evolution of computer technology, including operating systems and applications, resulted in designing intelligent machines that can recognize the spoken word and find out its meaning. Different front-end models have specific processing time required for calculating the same number of coefficients used for pattern recognition. During the years, it has been significantly improved, not only thanks to improvements in algorithms, but also with more processing power of nowadays computers. In this paper we analyze processing time and reconstructed speech quality of the three common front-end methods (Linear Predictive Coding LPC, Mel-Frequency Cepstrum MFC, and Perceptual Linear Prediction PLP) for calculating coefficients. Reconstructed speech quality is measured with Perceptual Evaluation of Speech Quality (PESQ) score. It is visible from our analysis that, if required,

higher number of coefficients could be used without significant impact on processing time for MFC and PLP coefficients

### **2.6.2.2 Acoustic modelling**

Acoustic modeling of speech typically refers to the process of establishing statistical representations for the feature vector sequences computed from the speech waveform. Hidden Markov Model (HMM) is one most common type of acoustic models. Other acoustic models include segmental models, super-segmental models (including hidden dynamic models), neural networks, maximum entropy models, and (hidden) conditional random fields, etc.

Acoustic modeling also encompasses “pronunciation modeling”, which describes how a sequence or multi-sequences of fundamental speech units (such as phones or phonetic feature) are used to represent larger speech units such as words or phrases which are the object of speech recognition. Acoustic modeling may also include the use of feedback information from the recognizer to reshape the feature vectors of speech in achieving noise robustness in speech recognition.

### **2.6.2.3 Language modelling**

There are two major types of language models. The older variety uses traditional statistical techniques like Hidden Markov Models (HMMs) and n-grams to assign probability distributions to word sequences. These models rely heavily on context, using their short-term memory of previous words to inform how they parse the next. A bigram model, for instance, uses the two previous words for inference while a trigram uses three. An n-gram, therefore, uses n words to make their predictions.

### 2.6.3 Mode of Transmission Of Signal Information.

GSM is a cellular network, therefore mobile phone can be connected to it by searching for cells in the immediate vicinity. GSM network operate in four different frequency ranges.

Frequency band (MHz)	Uplink frequency (MHz)	Downlink frequency (MHz)
900MHz	890-915 MHz	935-960 MHz
1800MHz	1710-1785 MHz	1805-1880MHz
1900MHz	1850-1915 MHz	1930 – 1995MHz

In GSM 900 MHz, the band allocation is 25 MHz bandwidth which is subdivided into 24 carrier frequency channels, each spaced 200 kHz apart.

Time division multiplexing is used to allow eight-half rate to sixteen half-rate speech channels per radio frequency channel. There are eight-radio time slots (giving eight burst periods) grouped into what is called TDMA frame. Half rate channels use alternate frames in the same time slot. The channels data rate is 270 833kbit/s and the frame duration is 4.615ms. The transmission power in the handset is limited to a maximum of 2 watts in GSM 900 and 1 watt in GSM 1800/1900. GSM has used a variety of voice codes.

#### **2.6.4 Subscriber Identity Module (SIM) as a GSM feature**

One of the key features of GSM is the subscriber identity module (SIM). It is usually known as SIM card.

The SIM is detachable smart in appearance and is used for the subscription of information and phonebook. This allows the retrieval of information after switching handset on. The SIM card also enables users to link each other irrespective of different network operation. For the purpose of this project work to be achieved a SIM card on any network is required to establish a link between a user and its household equipment to squeeze 3.1KHz audio between 5.6 and 13kbps/s.

### **2.7 Research Gap**

A home automation system means to grant the end users to manage and handle the electric appliances. Looking at different home automation systems over time, they have always tried to provide efficient, convenient, and safe ways for home inhabitants to access their homes but are mostly limited to appliances like TVs, AC, etc. Many existing, well-established home automation systems are based on Bluetooth connection which has a limitation since other users can connect and take control. This project is made up of a mobile phone, SIM 900 GSM module and only users with the “code command” can operate the security lightning, making it more secured.

## **CHAPTER THREE**

### **3.0 RESEARCH METHODOLOGY**

Chapter 3 provides detailed descriptions of the research design and the methodology used in for the present study. The study employs the explanatory mixed methods. It will obtain statistical, quantitative results from a sample and then follow-up with a few individuals to probe or explore those results in more depth.

The methodology is discussed, presented and addressed in this chapter. In research, methodology is critical because it allows anybody interested in the study to assess the validity and reliability of the method used, which has a direct impact on how the findings and conclusions are accepted.

Validity, according to Babbie et al. (2001), is the degree to which an empirical measure accurately reflects the true meaning of the topic under discussion. As a result, this Chapter covers the research design, block diagram of the project, the circuit diagram and its operation, materials and their description, flowchart, program code and software used.

#### **3.1 Hardware Subsystems**

The project was designed and implemented using top to bottom design method just as shown in the block diagram in figure 1. The system starts form the following units:

- Mobile phone
- GSM module 900
- Arduino

- Relay
- Power supply
- Lights

### Block Diagram

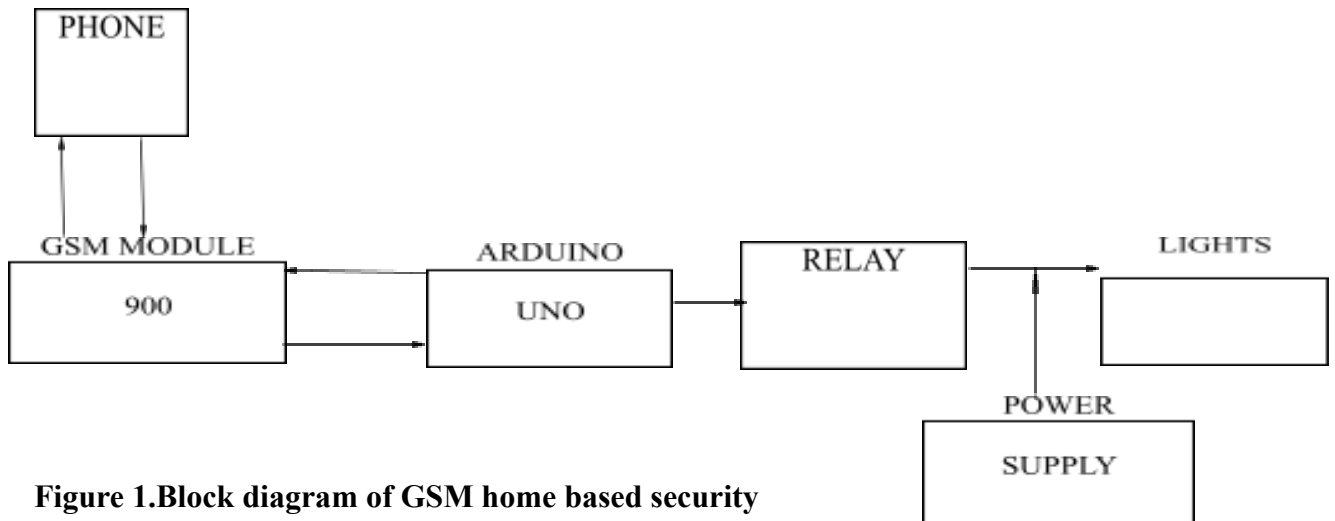

**Figure 1. Block diagram of GSM home based security lightning system.**

In the methodology, the overall system design is in two parts: hardware design and software design. The hardware design is the physical parts of the system while the software design treats the programs that were written to control the microcontroller at the processing center of the system. The hardware design is the heart of the project. This is the physical implementation where the various components used for the design were incorporated together on a Vero board through soldering. It consists of many units which includes a GSM module, Arduino Uno and other units listed above.

### 3.2 System Design And Analysis

The system uses GSM signal system which allows its users to effectively control their security lights simply by messaging the device. The message received by the device is processed by a microcontroller to perform an OFF/ON operations. The type of the operation performed is based on the nature of the GSM signal sent. An encoded GSM signal is generated and sent from the GSM base station to the device. In this project two GSM module are involved:

- The GSM transmitter module which is the user's cell phone
- The GSM receiver module which is the cell phone connected to the project.

There are lots of remote controls methodology like INFRARED, RF, CALLING and more but in this project messaging the system using GSM network is preferred. In the design methodology, GSM network was used because of its wider coverage. The relay driver is used to drive the relay circuits which switches the security lights connected to the output of the project. The figure shown above is the schematic diagram of the project. It is a simple illustration of how the project has been implemented and the various parts involved in it. From the above representation, the first Mobile station is used as a transmitting section from which the subscriber sends a SMS (short message service) which is the command or instruction for the second mobile station. A SIM card is inserted in the receiver cell phone.

### 3.3 Circuit Diagram

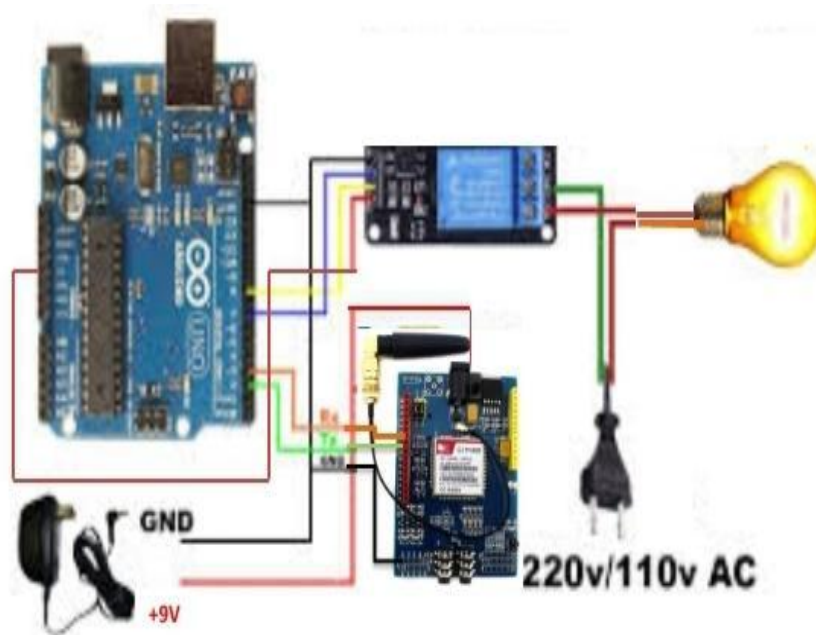
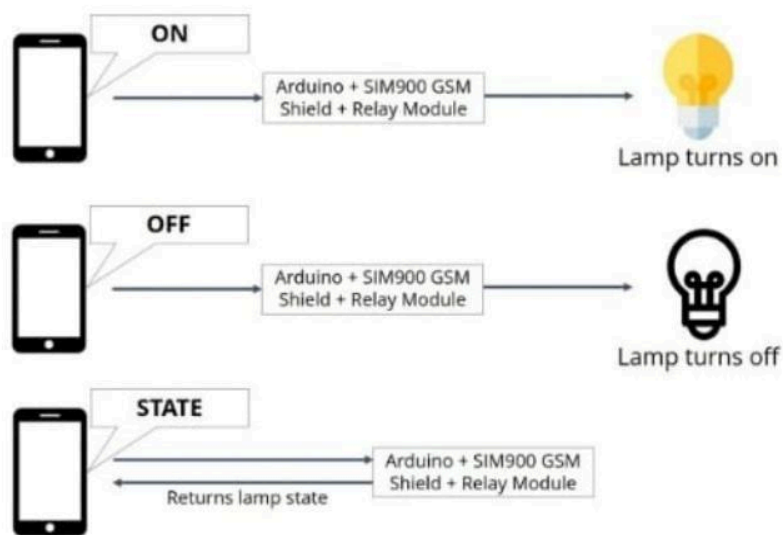

**Figure. 2 circuit diagram of GSM home based security lightning system**

Both the GSM module and the relay are connected to the Arduino through both the digital and the analog pins to be able to send and receive signals between the GSM module and the Arduino microcontroller. The relay is controlled by the Arduino board through the GSM module via SMS.

In this project, **Arduino** is used for controlling whole the process. GSM wireless communication is used for controlling the security lights. We send some commands like “ON” to turn on the lights, “OFF” to turn off the lights and “STATE” to read the condition of the lights. After receiving given commands by Arduino through GSM, Arduino sends signal to relays, to switch ON or OFF the security lights using a relay driver. When we send SMS to GSM module by Mobile, then GSM receives that SMS and sends it to Arduino. Now Arduino reads this SMS and extract main command from the received string and stores in a variable. After this, Arduino compare this string with predefined string. If match occurs then Arduino sends signal to relay via relay driver for turning ON and OFF the security lights.

### 3.4 System Flowchart



**Figure. 3 flowchart of GSM home based security lightning system**

This project uses the SIM900 GSM shield to receive and send SMS with the Arduino.

The flowchart of the system is explained below;

- Turn a 220/240V lamp on when you send an SMS to the Arduino with the text "ON"
- Turn a 220/240V lamp off when you send an SMS to the Arduino with the text "OFF"
- You can request the lamp state by sending an SMS to the Arduino with the text "STATE" the Arduino should reply back with the text "lamp is on" or "lamp is off"

### 3.5 Description Of Components

A lot of components were used to implement this project. Below are the list of components used in a bid to achieve the proposed project.

**Table 3.4.1 Table of Components**

Serial Number	Components	Quantity
1	Arduino Uno	1
2	SIM 900 GSM module	1
3	2 channel relay	1
4	Modem(Mobile phone)	1
5	12V power supply	1
6	LED	2
7	Resistors	2

## □ Arduino UNO

Arduino is a small micro-controller board with a Universal Serial Bus (USB) plug into connect to a computer and a number of connection sockets that can be wired up the external circuit, including the motor, sensors, and display. The Arduino can either be powered through the USB connection from the computer or from a 9V - 12V DC power adaptor. It is programmed by the computer, disconnected and allowed to work independently. It also easy to program as compared to other micro-controller.



**Figure.4 Arduino UNO**

## Main Features of Arduino Uno

Arduino UNO is a microcontroller board based on the **ATmega328P**. It has 14 digital input/output pins (of which 6 can be used as PWM outputs), 6 analog inputs, a 16 MHz ceramic resonator, a USB connection, a power jack, an ICSP header and a reset button. It contains everything needed to support the microcontroller; simply connect it to a computer with a USB cable or power it with an AC-to-DC adapter or battery to get started. The arduino UNO can be repaired without worrying too much about doing something wrong, worst case scenario the chip of the arduino UNO can be replaced and start over again.

### ATmega328P

The classic high-performance, low-power AVR® microcontroller.

### Replaceable chip

The ATmega328P can easily be replaced, as it is not soldered to the board.

### EEPROM

The ATmega328P also features 1kb of EEPROM, a memory which is not erased when powered off.

### Battery Connector

The Arduino UNO features a barrel plug connector that works great with a standard 9V battery.

#### ❑ GSM-Module 900

GSM stands for global system for mobile communication. This device works on IEEE 802nWireless Standard. They support advance text commands for communication between users to network providers. The communication from the computer to GSM Company has already provided onboard the RS232 to TTL converter in it.



## **Figure. 5 GSM module 900**

### **Features of GSM module 900**

**Here's some of the most important features of the shield:**

- Compatible with Arduino and clones
- Based on SIM900 module from SIMCOM
- Allows you to send SMS, MMS, GPRS and Audio via UART using AT commands.
- It has 12 GPIOs, 2 PWMs and built-in ADC of the SIM900 module
- Quad Band: 850; 900; 1800 and 1900 MHZ, so it should work in all countries with GSM (2G) networks
- Control via AT commands
- Has microphone and headphone jacks for phone calls
- Supports RTC (real time clock) – it has a holder for a 3V CR1220 battery at the back

### **Hardware Overview of SIM900 GSM/GPRS Shield**

The SIM900 GSM/GPRS shield is designed to surround the SIM900 chip with everything necessary to interface with Arduino, plus a few extra goodies to take advantage of the chip's unique features.

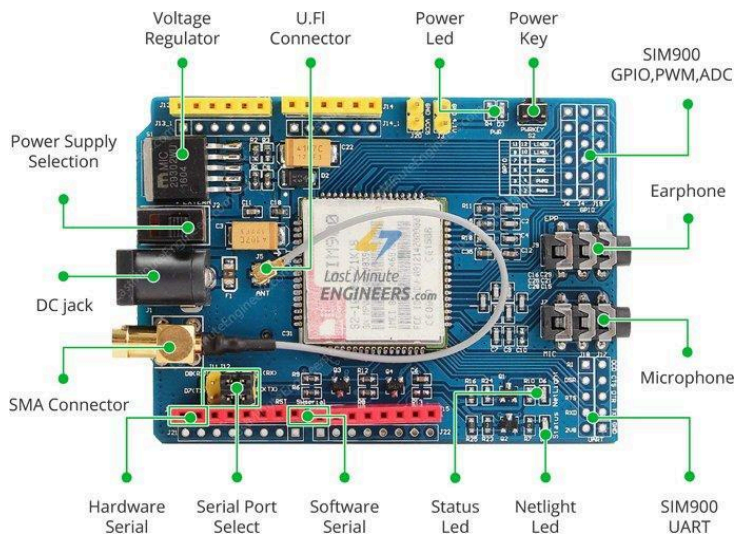

**Figure.6 front view of the GSM module 900**

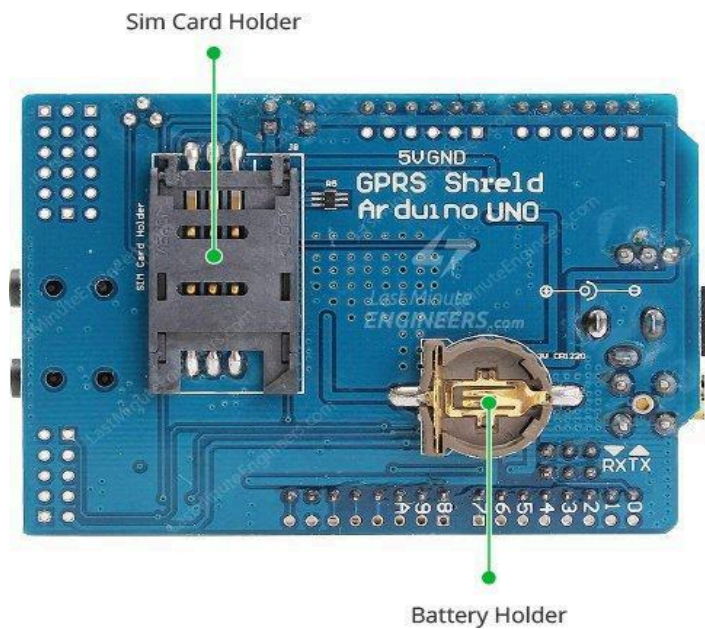

**Figure.7 back view of the GSM module 900**

## □ Relay Modules

A power relay module is an electrical switch that is operated by an electromagnet. The electromagnet is activated by a separate low-power signal from a micro controller. When activated, the electromagnet pulls to either open or close an electrical circuit.

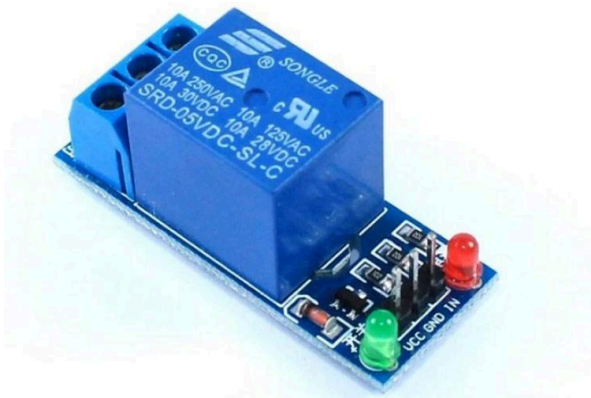

**Figure.8 5v channel relay**

Relay is the main control switch that shutdown the house appliances when a call is made. A relay is an electromagnetic operated switch. Current flowing through the coil of the relay creates a magnetic field, which attracts a lever and changes the switch contacts. The coil current can be on or off so relays have two switch positions and they are double throw switches. To prevent damage to the relay a diode must be connected across the relay coil. The relay's switch connections are usually labelled COM, NC and NO:

**Table 3.4.2: Pin Configuration and meaning**

PIN CONFIGURATION	MEANING
-------------------	---------

<b>COM</b>	<b>Common, it is the moving part of the switch</b>
<b>NC</b>	<b>Normally closed is connected to the COM when the relay coil is off</b>
<b>NO</b>	<b>Normally open is connected to the COM when the relay coil is on</b>

### □ **Modem(Mobile Phone)**

A GSM modem is a specialized type of modem which accepts a SIM card, and operates over a subscription to a mobile operator, just like a mobile phone. From the mobile operator perspective, a GSM modem looks just like a mobile phone. A GSM modem can be a dedicated modem device with a serial, USB or Bluetooth connection, or it can be a mobile phone that provides GSM modem capabilities. Global System for Mobile Communications (GSM) modems are specialized types of modems that operate over subscription based wireless networks, similar to a mobile phone. A GSM modem accepts a Subscriber Identity Module (SIM) card, and basically acts like a mobile phone for a computer. Such a modem can even be a dedicated mobile phone that the computer uses for GSM network capabilities.



**Figure.9 Modem (mobile phone)**

### □ **Power Supply**

A 12v DC Power supply is fed with 220/230 AC voltage which is connected to the input voltage pin ( $V_{in}$ ) of the Arduino microcontroller module. The module has an onboard voltage regulator that drops the voltage to a constant 5 volts output for the entire circuit operation. It also supplies the solenoid with power.

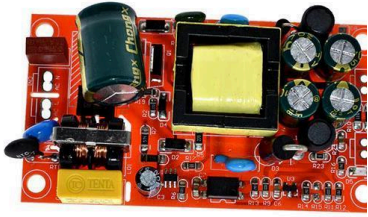

**Figure.10 12V power supply**

### □ **Light Emitting Diode (LED)**

LED falls within the family of P-N junction devices. The light emitting diode (LED) is a diode that will give off visible light when it is energized. In any forward biased P-N junction there is, with in the structure and primarily close to the junction, a recombination of hole and electrons. This recombination requires that the energy possessed by the unbound free electron be transferred to another state. The process of giving off light by applying an electrical source is called electroluminescence.

LED is a component used for indication. All the functions being carried out are displayed by led. The LED is diode which glows when the current is being flown through it in forward bias condition. The LEDs are available in the round shell and also in the flat shells. The positive leg is longer than negative leg.



**Figure.11 Light emitting diode**

## □ Resistor

The flow of charge through any material encounters an opposing force similar in many respects to mechanical friction. This opposing force is called resistance of the material. In some electric circuit resistance is deliberately introduced in form of resistor. Resistor used fall in three categories, only two of which are colour coded which are metal film and carbon film resistor. The third category is the wire wound type, where value are generally printed on the vitreous paint finish of the component. Resistors are in ohms and are represented in Greek letter omega, looks as an upturned horseshoe. Most electronic circuit requires resistors to make them work properly and it is obviously important to find out something about the different types of resistors available. Resistance is measured in ohms; the symbol for ohm is an omega ohm. 1 ohm is quite small for electronics so resistances are often given in  $k\Omega$  and  $M\Omega$ . Resistors used in electronics can have resistances as low as 0.1 ohm or as high as 10  $M\Omega$ .



**Figure.12 resistor**

## □ Software and Tools Used

The software and tools used to implement this project are;

- **The Proteus Design Suite** is a proprietary software tool suite used primarily for electronic design automation. The software is used mainly by electronic design engineers and technicians to create schematics and electronic prints for manufacturing printed circuit boards.



**PROTEUS**

- **The Arduino development environment (IDE)** contains a text editor for writing code, a message area, a text console, a toolbar with buttons for common functions, and a series of menus. It connects to the Arduino hardware to upload programs and communicate with them. It has many built in libraries along with libraries for LCD display. We can also install third party library in the latest IDE of Arduino.



## **Program/Code**

```
#define poweredled 3
```

```
// Include Software Serial library to communicate with GSM
```

```
#include <SoftwareSerial.h>
```

```
// Configure software serial port

SoftwareSerial SIM900(7, 8);

// Variable to store text message

String textMessage;

// Create a variable to store Lamp state

String lampState = "HIGH";

// Relay connected to pin 12

const int relay = 12;

void setup() {

// Automatically turn on the shield

pinMode(9,OUTPUT);

pinMode(powerled, OUTPUT);

digitalWrite(powerled,HIGH);

digitalWrite(9, HIGH);

delay(1000);
```

```
digitalWrite(9, LOW);

delay(5000);

// Set relay as OUTPUT

pinMode(relay, OUTPUT);

// By default the relay is off

//digitalWrite(relay, HIGH);

// Initializing serial communication

Serial.begin(19200);

SIM900.begin(19200);

// Give time to your GSM shield log on to network

delay(20000);

Serial.print("SIM900 ready...");

// AT command to set SIM900 to SMS mode

SIM900.print("AT+CMGF=1\r");

delay(100);
```

```
// Set module to send SMS data to serial out upon receipt

SIM900.print("AT+CNMI=2,2,0,0,0\r");

delay(100);

}

void loop(){

if(SIM900.available()>0){

    textMessage = SIM900.readString();

    Serial.print(textMessage);

    delay(10);

}

if(textMessage.indexOf("ON")>=0){

    // Turn on relay and save current state

    digitalWrite(relay, HIGH);

    lampState = "on";

    Serial.println("Relay set to ON");
```

```
    textMessage = "";

}

if(textMessage.indexOf("OFF")>=0){

    // Turn off relay and save current state

    digitalWrite(relay, LOW);

    lampState = "off";

    Serial.println("Relay set to OFF");

    textMessage = "";

}

if(textMessage.indexOf("STATE")>=0){

    String message = "Lamp is " + lampState;

    sendSMS(message);

    Serial.println("Lamp state resquest");

    textMessage = "";

}
```

```
}
```

```
// Function that sends SMS
```

```
void sendSMS(String message){
```

```
    // AT command to set SIM900 to SMS mode
```

```
    SIM900.print("AT+CMGF=1\r");
```

```
    delay(100);
```

```
    // REPLACE THE X's WITH THE RECIPIENT'S MOBILE NUMBER
```

```
    // USE INTERNATIONAL FORMAT CODE FOR MOBILE NUMBERS
```

```
    SIM900.println("AT + CMGS = \"0240748574\");
```

```
    delay(100);
```

```
    // Send the SMS
```

```
    SIM900.println(message);
```

```
    delay(100);
```

```
// End AT command with a ^Z, ASCII code 26

SIM900.println((char)26);

delay(100);

SIM900.println();

// Give module time to send SMS

delay(5000);

}
```

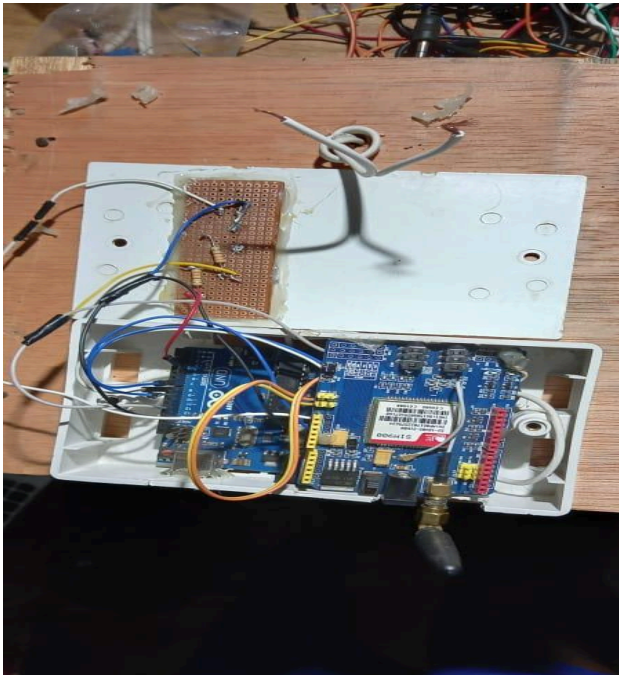

**Figure.13 System design setup**

## **CHAPTER FOUR**

### **4.0 SYSTEM IMPLEMENTATION, CONSTRUCTION, TESTING AND INTEGRATION**

#### **4.1 Choice of Development Tools**

To ensure a standardized object oriented program, assembly language is used as the programming language that will run the circuit.

#### **4.2 System Requirement**

In order to achieve this project, the following hardware and software requirements were needed

##### **4.2.1 Software Requirement**

- Windows 98/2000/xp or any version of windows
- Assembly language

##### **4.2.2 System Hardware Requirement**

The microcontroller based GSM control system is an electronic device that is made up of different kinds of components which are put together to perform a particular task. These components are

- Arduino Uno
- SIM 900 GSM module
- 2 channel relay
- Modem (Mobile phone)
- 12V power supply
- LED
- Resistors
- Connecting wires
- Vero board etc.

### **4.3 Steps To Construction Of GSM Home Based Security Lightning System.**

The project was constructed based on a series of steps which is described below.

#### **4.3.1 Design Of The System Block Diagram**

This is the physical implementation where the various components used for the design were incorporated together on a Vero board through soldering. It consists of many units which includes a GSM module, Arduino Uno and other units.

#### **4.3.2 Inspection And Preparation Of The Vero Board**

The construction of this project was done on a Vero board. Vero board is also called strip board. It is a widely-used type of electronics prototyping board characterized by a 0.1 inch (2.54 mm) regular (rectangular) grid of holes, with wide parallel strips of copper cladding running in one direction all the way across one side of the board. In using the board, breaks are made in the tracks, usually around holes, to divide the strips into multiple electrical nodes. With care, it is possible to break between holes to allow for components that have two pin rows only one position apart such as twin row headers for ICs.

**Vero board:** The construction of this project was done on a Vero board and the procedure methods used are: -

1. The Vero board was inspected of wrong linkages of its line which may be mistake from the producers. The holes of the board were inspected to be through for passing the terminals of the components for soldering.
2. An abrasive paper was used on the soldering section of the board for easy binding of the terminals on the board.

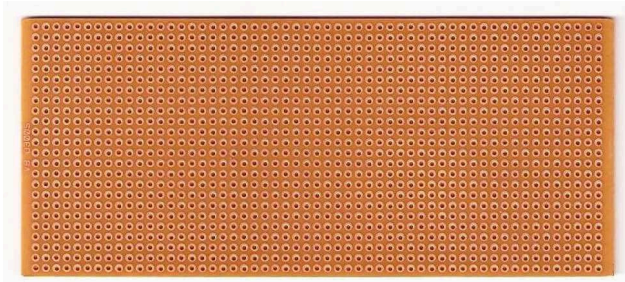
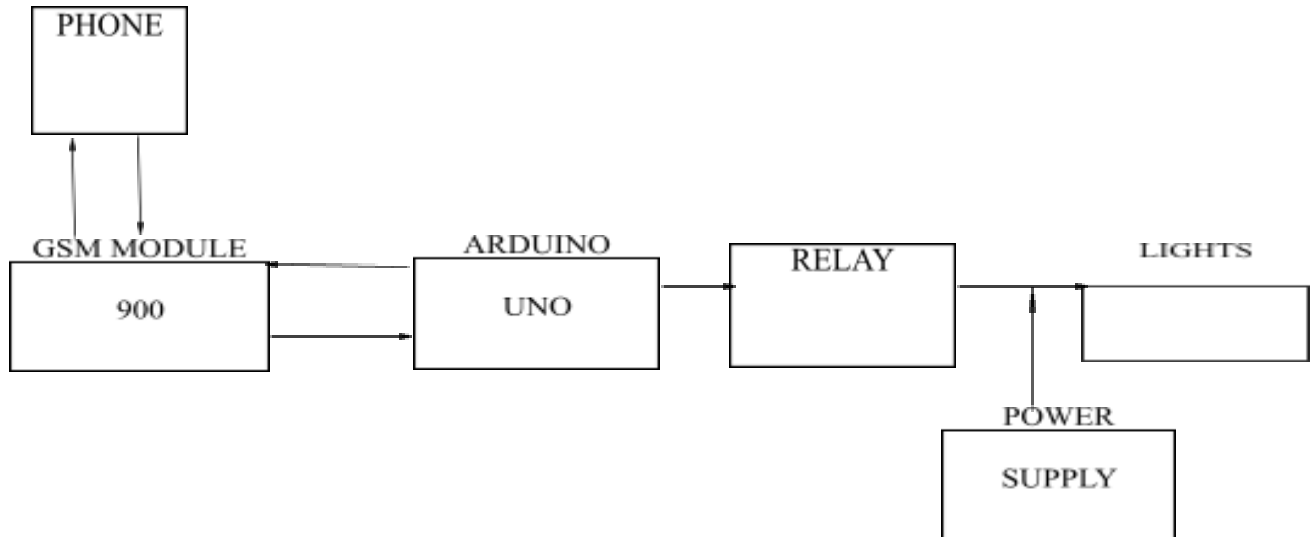

**Figure 1. Vero board**

Components are usually placed on the plain side of the board, with their leads protruding through the holes. The leads are then soldered to the copper tracks on the other side of the board to make the desired connections, and any excess wire is cut off. The continuous tracks may be easily and neatly cut as desired to form breaks between conductors using a 5mm twist drill, a hand cutter made for the purpose, or a knife. Tracks may be linked up on either side of the board using wire. With practice, very neat and reliable assemblies can be created, though such a method is labor-intensive and therefore unsuitable for production.

### 4.3.3 Mounting Of The Components

The mounting of the components were placed according to block diagram below.



The soldering process was carried out using a lead and soldering iron. This was done by joining the supposed terminals together before soldering. And after soldering each unit, test was carried out using a meter to ensure good contact. A pattress box was used for the enclosure of the project. Pattress is an electrical installation box used for housing electrical/electronic components. It is made of plastic material, 50×20mm rectangular shape with 10mm thickness. This box houses the control unit.

### 4.3.4 Interconnection Of Components

The interconnections of the circuit were done using a PVC connecting wire. This enabled the necessary connections at different sections of the circuit to be made by extending the terminals or connection made with a wire to a deserved point in the circuit. Connecting wires is a flexible wire made from copper and will be used to connect component or subsystems.

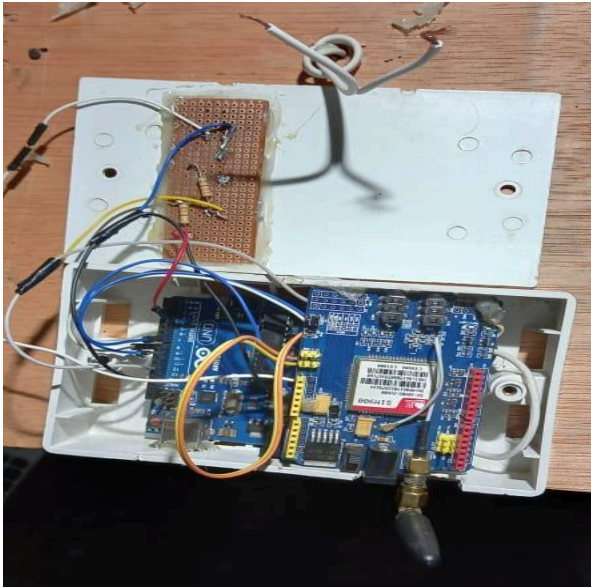

**Figure 3. Complete construction of the project**

#### **4.4 Implementation Of The Project**

In the implementation, the load (lights) to be controlled is connected to the relay which in turn is connected to the different ports of the Arduino Uno. This is to help in the switching unit of the circuit. A power supply is connected to A.C to step the voltage down to 12v. The power supply will be connected to a bridge rectifier to convert the A.C to D.C that will be used by the circuit. The completed circuit works with an algorithm as programmed into the microcontroller chip. In this project, a particular command codes is designed for turning on and off the security lights. The relay has been programmed to respond to commands using the SMS commands from the transmitter/mobile phone.

#### **4.5 Testing**

Testing is finding out how well something works. With this definition, we can define testing as the series of trial run-throughs of a process to find if it works. Physical examination and testing of component is the first test performed before developing the unit system that makes up the actual one; a project work must undergo series of test before the project will be satisfied okay in production chain, a satisfactory label often written Q.C passed is tagged to a finished product. In small system designs testing process is also applicable. These are the sequence of test needed to undergo for any successful project work.

- Testing of the individual components.
- Unit by unit testing.
- System testing.

#### **4.5.1 Testing Of The Individual Components**

The components were tested individually before fiddling with it so as to remove the bad ones. The pins of soldered components on the Vero-board were checked for dry joints and a digital multimeter was set to resistance mode to test for short circuiting between the connections. The wires used for the connection of the various components were also tested for 'continuity' to ensure that there was no cutoff during the transfer from the bread-board to the Vero-board. This test will be a satisfied test measures for individual components which are basically done by using of the multimeter (e.g. testing of diodes, resistors, LEDs, and every other component that will be used in the project.

#### **4.5.2 Unit By Unit Testing**

This involves wiring up of the circuit, testing and satisfying its functions before soldering. Examples are bread boarding of power supply stage of the project, testing it and confirming that it is functional before soldering.

### 4.5.3 System Testing

System testing involves the testing of the entire circuitry and cross examining it for errors like short circuits, lead flux joining unwanted links, proper insertion IC pin layout. After this check cross examine once again before powering the system.

### 4.6 Packaging

Packaging is done after the system testing. Every good product is often determined by its packaging. Credit is awarded to a properly packaged project. After integrating and final testing of the project, choice of packaging would be considered. Factors to consider include cost, as well durability and elegance. A plastic casing was used to house the project. Before the construction of this package, the size of the project and maintenance factor which need may arise was also considered. There are some other medium for packing the project like metallic package. This would have been a better option, but due to cost of production. Wood was another option. It is relatively cheaper. But the beauty of the project was put into consideration thus, the choice of wood and plastic casing.

<b>S/ N</b>	<b>COMPONENTS</b>	<b>QUANTITY</b>	<b>UNIT PRICE</b>	<b>AMOUN T (GHS)</b>
-----------------	-------------------	-----------------	-----------------------	------------------------------

1	Arduino Uno	1	120	120
2	SIM 900 GSM Module	1	180	180
3	2 Chanel relay	1	20	20
4	12V power supply	1	70	70
5	LED	2	5	10
6	Resistors	2	2.5	5
7	9V battery	1	30	30

8	Bulb	1	5	5
9	Pattress box	2	7, 5	12
10	SIM card	1	5	5
11	Shipping	-	-	25
			<b>TOTA</b>	<b>482</b>
			<b>L</b>	

#### 4.7 Bill Of Materials And Evaluation



## **CHAPTER 5**

### **5.0 SUMMARY, RECOMMENDATIONS AND CONCLUSION**

#### **5.1 Summary Of Findings**

The design of this remote control system using GSM phone involves researches in different aspects of Electrical/Electronic Engineering. This includes power electronics, differential amplifier, telecommunication, digital electronics and software engineering. Thorough work was done in all these aspects of engineering before the work could be concluded. The project is a clear indication of a multipurpose control done via the keypad tone reducing the manual efforts and time required while paying individual attention for controlling the security lights.

This research work saves time and energy of the individual. The system requires less design and implementation cost. For handicapped people, this system helps them to operate their home security lights conveniently. In every aspect of our daily lives people ranging from scientist to handymen and farmers can make use of this system for controlling their home security lights.

#### **5.2 Major Constraints Of The Project**

Along the course of the project completion various problems and obstacles were encountered. Not everything that was planned went smoothly during the project development span. Also, there was a limited amount of time for its completion so there was a lot of pressure

completing the project. There was the need to start from the research phase at the beginning and the need to gain knowledge on all the devices and components that will be used for the project. Other phases of the project included coding, debugging, testing, documentation and implementation and it needed certain time for completion so there was the need to manage the limited time available to work accordingly to finish the project within the schedule.

### **5.3 Constraints Considerations**

The following is a list of constraint considerations

- The controlled appliance will need an electrical control interface. This system is only capable of controlling electrical devices.
- The control module will need to be shielded against electrostatic discharges. This will increase the reliability of the system.
- Battery backup for controlling unit can be implemented in case of power disruption.

### **5.4 Technology Considerations**

The considerations for this system will include a choice of networks, communication protocols and interfaces.

- Cellular Networks: The widely available networks are based on GSM. This network provides wide area coverage and can be utilized more cost effectively for this project.
- Communication Protocols: The available communication protocol that we have used is phone sms. The sms is the most efficient because this project requires a cellular communication and limited data to be sent.
- I/O interfaces between microcontroller and devices: Serial I/O is considered as options for connection between the GSM receiver and the microcontroller. Using the microcontroller, a control circuit will be implemented to control the electrical appliance.

## **5.5 Recommendations**

This system is designed specifically to operate security lightning in homes easily from a distance. It can still be improved to provide a more efficient and effective means to control security lightning in homes.

The following recommendations are useful;

1. Two layers circuit board can be designed and used in place of single layer circuit board for easier soldiering work and neatness.
2. The design is best implemented using a printed circuit board (PCB) technology for the circuit layout to produce a neat arrangement of components.
3. A mobile application can be substituted for the SMS that is used to control the system, this will limit/stop airtime consumption.

## **5.6 Conclusion**

This design and construction of a remote system using GSM network was carried out considering some factors, which includes availability of components, cost effectiveness of design, economic application, research materials, efficiency, portability and finally its durability. The system after completion and normal test met the expected design specification and performance. But misuse of the system by end users may probably lead to lapses in the system performance. The system was designed and constructed in such a way that maintenance and repairs are easily done in the case of faults. Soldering techniques and

practical electronic were carefully studied and the experience gain from it was instrumental to the success of this project.

## REFERENCES

1. Douglas V. H. (1999). Microprocessor and Interfacing – programming and hardware .Tata McGraw Hill 2nd Edition <http://cslu.cse.ogi.edu/asr/>.  
[http://murray.newcastle.edu.au/users/staff/speech/home\\_pages/tutorial\\_sr.html](http://murray.newcastle.edu.au/users/staff/speech/home_pages/tutorial_sr.html).
2. Jelinek F. (1997). Statistical Methods for Speech Recognition. Massachusetts Institute of Technology, Cambridge.
3. John Iovine. (June 1995). DTMF IR Remote Control System.
4. Rabiner L.R, Juang B.H. (1986). An introduction to HMMs. IEEE ASSP Magazine 3.
5. Rabiner L.R., Juang B.H. (1993). Fundamentals of Speech Recognition. Prentice Hall, Englewood Cliffs, N.J.
6. Robert L. Boylestad,,Louis Nashelsky. (1999). Electronic Devices and Circuit Theory (Eight Edition).
7. Alkar, A. Z., & Buhur, U. (2005). An Internet Based Wireless Home Automation System for Multifunctional Devices. IEEE Consumer Electronics, 51(4), 1169-1174
8. Ciubotaru-Petrescu, B., Chiciudean, D., Cioarga, R., & Stanescu, D. (2006). Wireless Solutions for Telemetry in Civil Equipment and Infrastructure Monitoring. 3rd Romanian-Hungarian Joint Symposium on Applied Computational Intelligence (SACI) May 25-26, 2006. Retrieved from <http://www.bmf.hu>
9. Conte, G., & Scaradozzi, D. (2003). Viewing home automation systems as multiple agents systems. RoboCUP2003,
10. Delgado, A. R., Picking, R., & Grout, V. (2006) Remote-controlled home automation systems with different network technologies. Proceedings of the 6th International Network Conference (INC 2006), University of Plymouth, 11-14 July 2006, pp. 357-366. Retrieved from <http://www.newi.ac.uk>
11. Potamitis, I., Georgila, K., Fakotakis, N., & Kokkinakis, G. (2003). An integrated system for smart-home control of appliances based on remote speech interaction. EUROSPEECH 2003, 8th European Conference
12. Y. Liu, "Study on Smart Home System Based on Internet of Things Technology," in Informatics and Management Science IV. vol. 207, W. Du, Ed., ed: Springer London, 2013, pp. 73-81.
13. Heckman, D. (2008), A Small World. Smart Houses and the Dream of the Perfect day, Duke University Press, London, UK.

14. Alkar, A. Z., & Buhur, U. (2005). An Internet Based Wireless Home Automation System for
15. Multifunctional Devices. IEEE Consumer Electronics, 51(4), 1169-1174. Retrieved from <http://www.thaieei.com>
  
16. CD4017B Data Sheet (1999). [Online] Available: <http://www.datasheetsdir.com/cd4017+download>
17. Delgado, A. R., Picking, R and Grout, V. (2016). Remote-controlled home automation systems with different network technologies Proceedings of the 6th International Network Conference (INC 2016), University of Plymouth, pp. 357-366. Retrieved from <http://www.newi.ac.uk/groutv/papers/p5.pdf>
18. Friedhelm, H. (2012). GSM and UMTS: The Creation of Global Mobile Communication, John Wiley.
19. Ohaneme, C.O, Akpado, K.A., Ifeagwu, E.N. and Ezeagwu, C.O. (2014). Implementation and Analysis of a GSM-Based Security System with Emergency Control, International Journal of Electronics Communication and Computer Engineering, 5(1), pp 134 – 141