

Marla Lopez

August 3rd, 2021

EEL3111C

# Final Project Report

## **Abstract**

A basic audio amplifier is built as the circuit of this lab. It consists of a high pass filter, gain stage, peak detectors, and an output stage. The high pass filter filters sound so that higher frequencies pass through, the cutoff frequency being about 1 kHz and anything lower is reduced by 3 dB. The gain stage makes the audio louder, it scales it so that the audio is played in volts rather than in the millivolts. The outputs from the gain stage is passed through peak detectors, where the first LED lights up if the output goes over 1 V, and the second LED lights up if the output goes over 4 V. The output of the gain stage is then passed through two op amp buffers in the output stage to solve impedance issues that may occur. There are two outputs for the left and right speakers.

Marla Lopez

August 3rd, 2021

EEL3111C

## Procedure

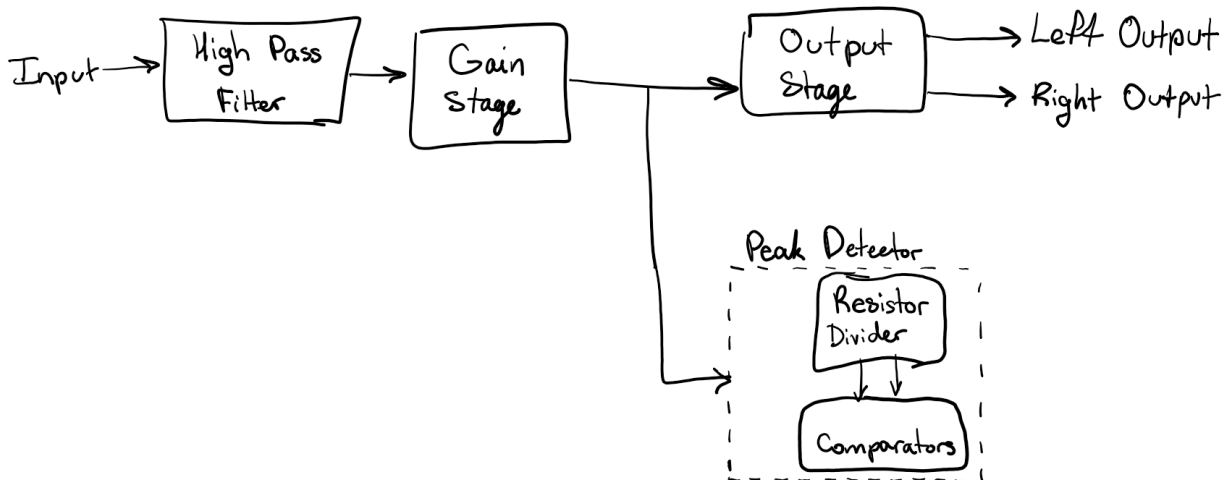

Figure 1: Block diagram of basic audio amplifier

1. Filter Stage: An active RC high pass filter is used to filter the input so that only frequencies above 1026 Hz are passed through. The rest are lowered by 3 dB. It also helps to remove the large DC offset. The filter also provides a gain of a magnitude of 10. The capacitor value used is 0.047  $\mu\text{F}$  and source resistor value 3.3kOhms is used to give the cutoff frequency of about 1 kHz.
2. Gain Stage: In the gain stage, the filtered input signal is the put through an inverting op amp. The gain is manipulated by the potentiometer, which acts as the source resistor. The potentiometer can go from very low resistance to 10kOhms, so the magnitude if the gain goes from near infinity to 12. This essentially controls how loud the output sound gets.
3. Peak Detector Stage: The peak detector is a clipping detection circuit. The voltage divider uses resistor to divide the voltage, which are 1 V and 4 V. These voltages are then input into two comparators, so that the input signal is compared to these two voltages. If the signal goes over 1 V, an LED will light up, and if it goes over 4 V, both LEDs light up. The resistor values used are

Marla Lopez

August 3rd, 2021

EEL3111C

1kOhm and 3kOhm, so the values are shifted by one between 0 and 5 V, and the comparing values are a 3 V difference.

4. Output Stage: In the output stage, the output signal of the gains stage is used as the input of two separate op amps. The op amps are made as two buffers to solve any impedance issues that may result from the previous stage. This is so that the signal does not over 5 V. There are two buffers for the output of the left and right speakers.

Marla Lopez  
 August 3rd, 2021  
 EEL3111C  
**Results**

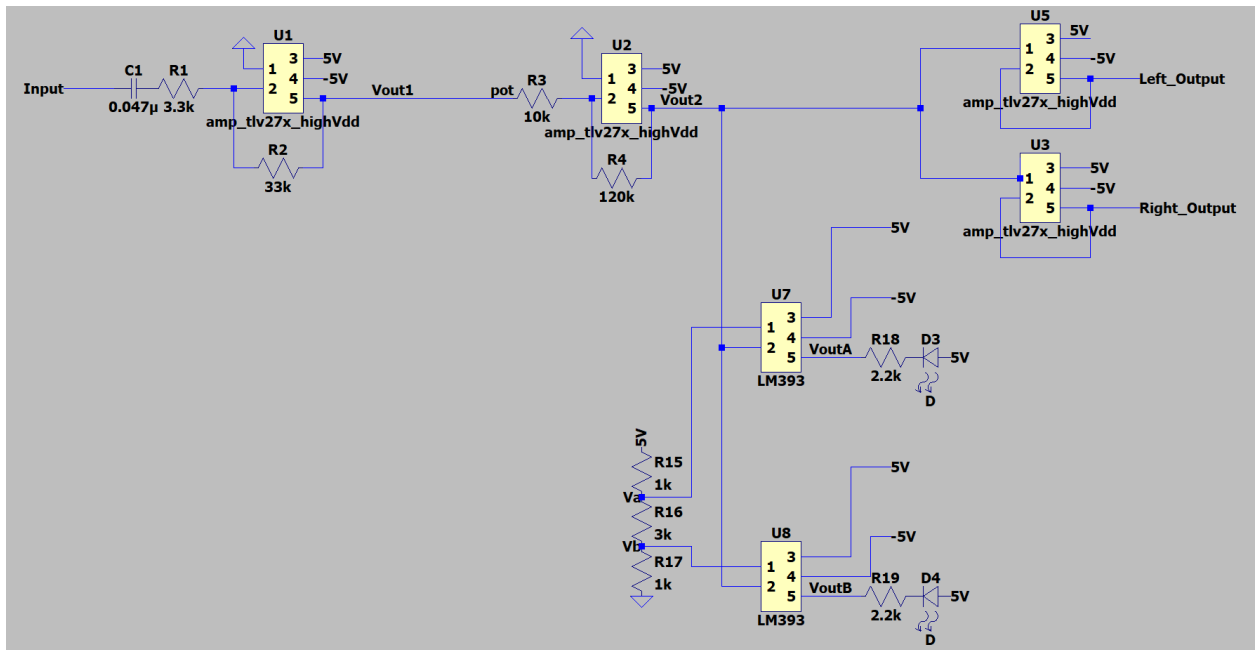

Figure 2: Circuit diagram of the audio amplifier.

Components				
Name	Quantity	Value	Price	Total Price
CRST103-P	1		\$1.02	\$1.02
TLV272IP	2		\$1.41	\$2.82
LM393P	1		\$0.40	\$0.40
LEDRWCT-1 3/4	2	Clear, Red	\$0.74	\$1.48
Capacitor	1	0.047 uF	\$0.47	\$0.47
Resistor	5	1 kOhm	\$0.00475	\$0.019
	2	2.2 kOhm	\$0.00475	\$0.0095
	1	3.3 kOhm	\$0.00475	\$0.00475
	1	33 kOhm	\$0.00475	\$0.00475
	1	120 kOhm	\$0.00475	\$0.00475
Overall Price				\$10.62

Table 1: List of components and their quantities, values, prices, and total price.

Marla Lopez  
August 3rd, 2021  
EEL3111C

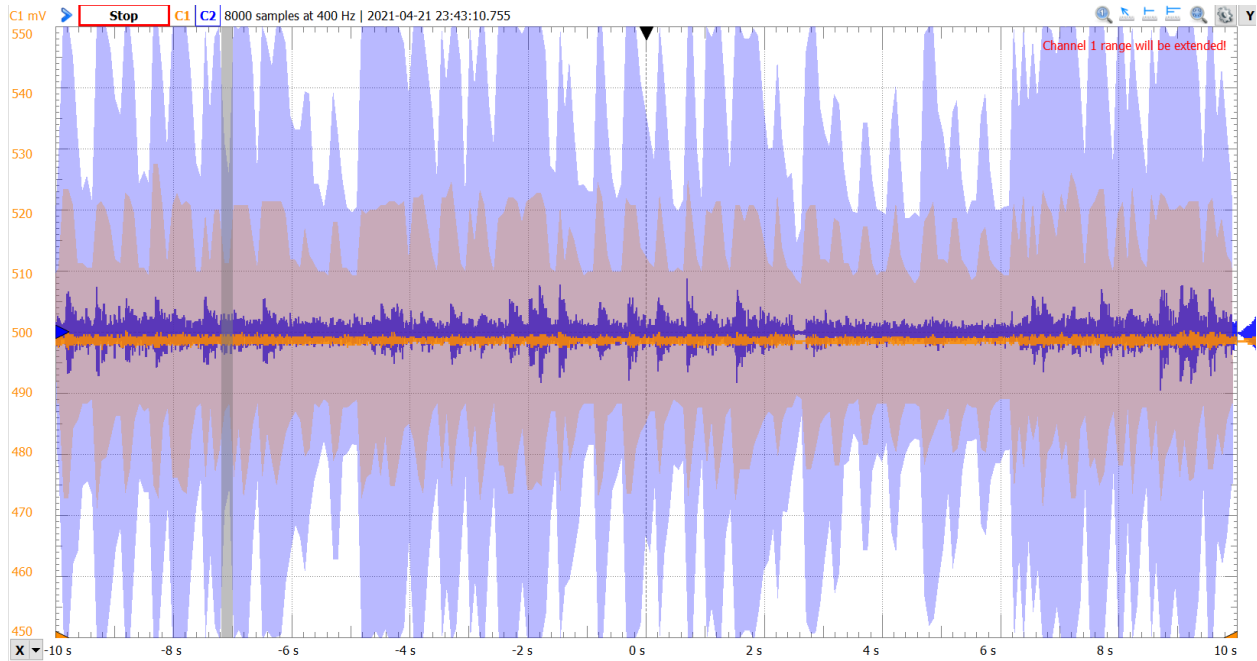

Figure 3: Scope plot of input and output of audio amplifier.

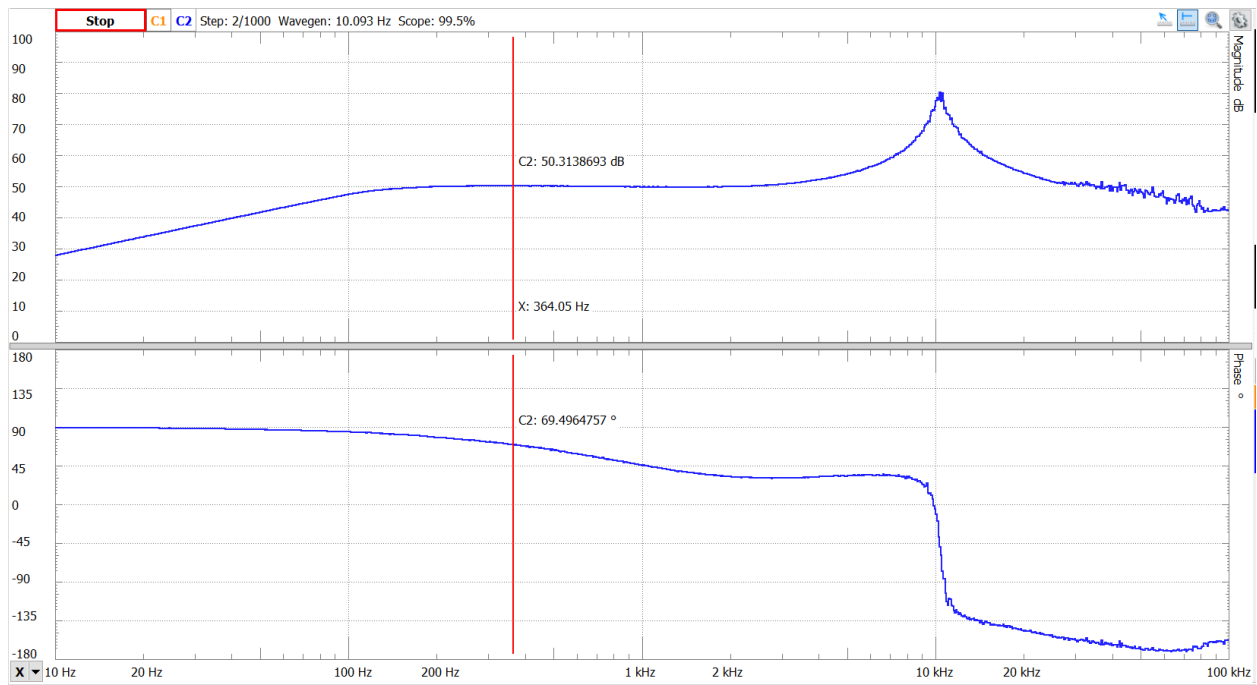

Figure 4: Network plot of output of audio amplifier.

Marla Lopez

August 3rd, 2021

EEL311C

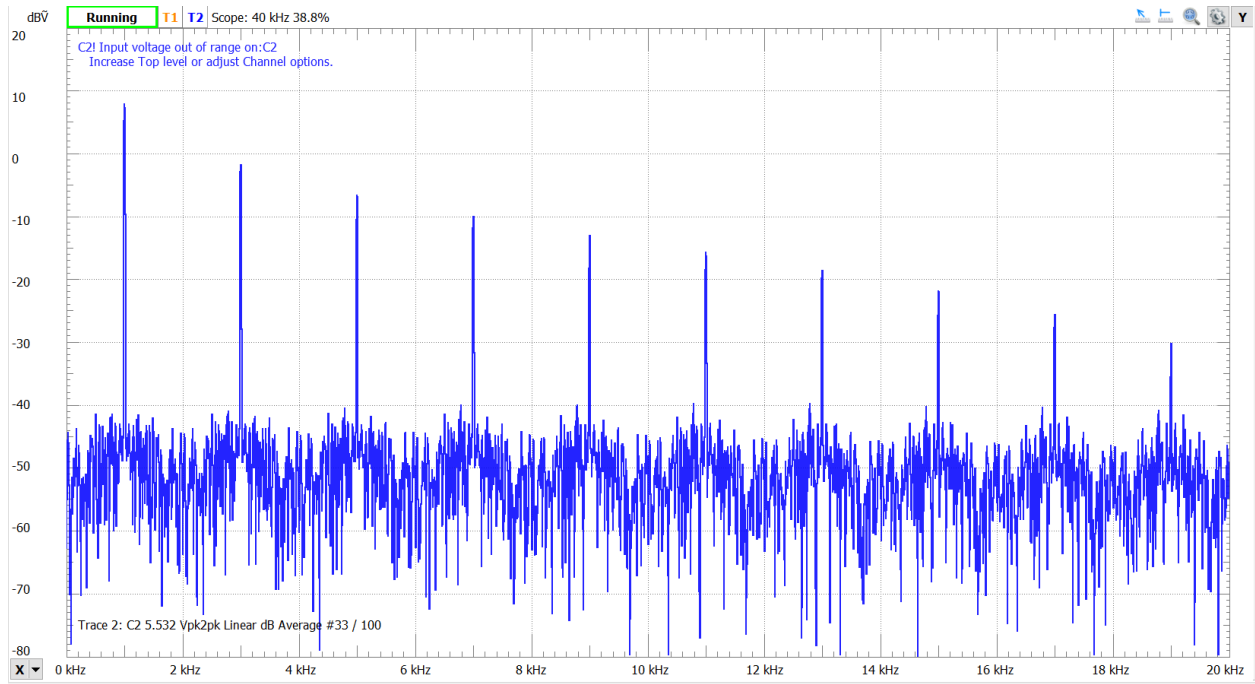

Figure 5: Spectrum plot of output of audio amplifier.

Marla Lopez

August 3rd, 2021

EEL3111C

### **Conclusion**

The circuit is a basic audio amplifier with four stages and two sub stages. The first stage is the high pass filter that filters the signal so that frequencies higher than 1kHz pass through. The second stage is the gain stage, a potentiometer is used as a source resistor so that the signal has a gain varying from near infinity and 12. The output of the gain stage is then fed into the peak detector stage, which consists of a voltage divider that is put into two comparators. The purpose of the peak detectors is to check when the output signal goes above 1 V and 4 V, which are indicated by 2 LEDs. The output of the gain signal is also put into two buffers in the output stage for the left and right speakers. This is to prevent any impedance issues caused in the previous stages, so that the signal doesn't go over 5 V or under -5 V.