

Type the paper title (Times New Roman 17pt)

First Author ^{a,1,*}, Second Author ^{b,2}

^a First affiliation, Address, City and Postcode, Country (9pt)

^b Second affiliation, Address, City and Postcode, Country (9pt)

¹ First Author Email; ² Second Author Email; ³ Third Author Email (9pt)

* Corresponding Author

ARTICLE INFO

Article history

Received Month xx, 20xx

Revised Month xx, 20xx

Accepted Month xx, 20xx

Keywords

Key 1;

Key 2;

Key 3;

Key 4;

Key 5

ABSTRACT

The abstract must contain 200-300 words that consist of
2-3 sentences about the introduction, problem, solution;
1-2 sentences about contribution;
2-3 sentences about the method;
4-5 sentences about the result; and
1-2 sentences about conclusions (10pt).

This is an open-access article under the [CC-BY-SA](#) license.



1. Introduction (Heading 1) (bold, 12 pt)

The minimal paragraph in the introduction is three paragraphs. The introduction section must contain the research problem (at least from 5 references), solution (at least from 5 references), state of the art, novelty, literature review from previous research (at least from 20 references), and **research contribution (the most important)**. Please state the problem and solution clearly. The minimal is one contribution must be stated in the introduction, such as “**The contribution of the research is...**” The manuscript structure is **Introduction, Method, Result and Discussion, and Conclusions**.

2. Method (bold, 12 pt)

2.1. Article Template (Heading 2) (bold, 11 pt)

The template is used to format your paper and style the text. All margins, column widths, line spaces, and text fonts are prescribed; please do not alter them. You may note peculiarities. For example, the head margin in this template measures proportionately more than is customary. This measurement and others are deliberate, using specifications that anticipate your paper as one part of the entire proceedings and not as an independent document. Please do not revise any of the current designations.

Before formatting your paper, write and save the content as a separate text file. Keep your text and graphic files separate until the text has been formatted and styled. Do not use hard tabs, and limit hard returns to only one return at the end of a paragraph—finally, complete content and

organizational editing before formatting. Do not add any kind of pagination anywhere in the paper. Do not number text heads-the template will do that for you.

2.2. Proposed Method

The proposed method is shown in Fig. 1. The setpoint is the reference signal. The tuning method is a coefficient diagram. The nonlinear model is the Maglev System. The output is object position. The difference between the setpoint and feedback is an error. The controller is integral to state feedback.

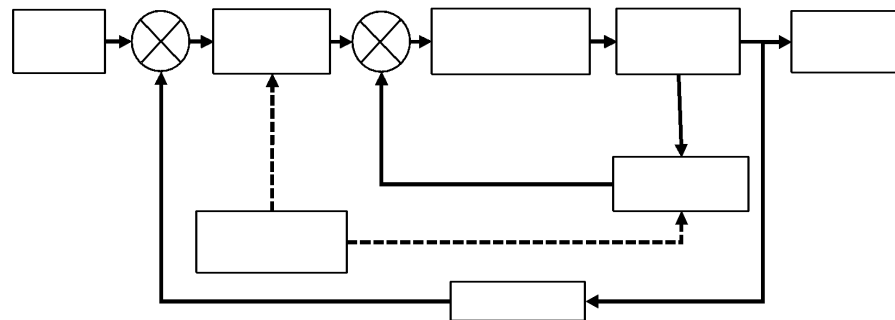

Fig. 1. The proposed method

2.3. Some Common Mistakes

There are common that must be carefully read, such as

- The word “data” is plural, not singular.
- The subscript for the permeability of vacuum μ_0 , and other common scientific constants is zero with subscript formatting, not a lowercase letter “o.”
- In American English, commas, semi-/colons, periods, questions, and exclamation marks are located within quotation marks only when a complete thought or name is cited, such as a title or full quotation. When quotation marks are used, instead of a bold or italic typeface, to highlight a word or phrase, punctuation should appear outside of the quotation marks. A parenthetical phrase or statement at the end of a sentence is punctuated outside of the closing parenthesis (like this). (A parenthetical sentence is punctuated within the parentheses.)
- A graph within a graph is an “inset,” not an “insert.” The word alternatively is preferred to “alternately” (unless you really mean something that alternates).
- Do not use the word “essentially” to mean “approximately” or “effectively.”
- In your paper title, if the words “that uses” can accurately replace the word using, capitalize the “u”; if not, keep using lower-cased.
- Be aware of the different meanings of the homophones “affect” and “effect,” “complement” and “compliment,” “discreet” and “discrete,” “principal,” and “principle.”
- Do not confuse “imply” and “infer.”
- The prefix “non” is not a word; it should be joined to the word it modifies, usually without a hyphen.
- There is no period after the “et” in the Latin abbreviation “et al.”
- The abbreviation “i.e.,” means “that is,” and the abbreviation “e.g.” means “for example.”

3. Results and Discussion

3.1. Authors and Affiliations

The template is designed so that author affiliations are not repeated each time for multiple authors of the same affiliation. Please keep your affiliations as succinct as possible (for example, do not differentiate among departments of the same organization).

3.2. Identify the Headings

Headings, or heads, are organizational devices that guide the reader through your paper. There are two types: component heads and text heads. Component heads identify the different components of your paper and are not topically subordinate to each other. Examples include Acknowledgments and References, and the correct style to use is “Heading 5.” Use “figure caption” for your Figure captions, and “table head” for your table title. Run-in heads, such as “Abstract,” will require you to apply a style (in this case, italic) in addition to the style provided by the drop-down menu to differentiate the head from the text.

Text heads organize the topics on a relational, hierarchical basis. For example, the paper title is the primary text head because all subsequent material relates and elaborates on this one topic. If there are two or more sub-topics, the next level head (uppercase Roman numerals) should be used and, conversely, if there are not at least two sub-topics, then no subheads should be introduced. Styles named “Heading 1,” “Heading 2,” “Heading 3,” and “Heading 4” are prescribed.

3.3. Figures and Tables

Place figures and tables at the top and bottom of columns. Avoid placing them in the middle of columns. Figure captions should be below the figures; table heads should appear above the tables. Insert figures and tables after they are cited in the text. Use the abbreviation “Fig. 3,” “Table 1,” even at the beginning of a sentence.

Table 1. Table Styles

Table Head	Table Column Head		
	Table column subhead	Subhead	Subhead
copy	More table copy		
copy	More table copy		
copy	More table copy		

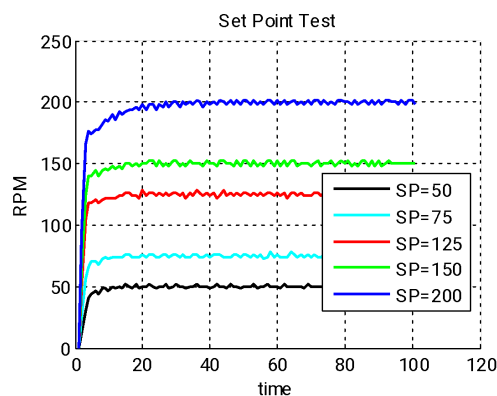

Fig. 2. Example of a figure caption

4. Conclusion

Provide a statement that what is expected, as stated in the "Introduction" chapter, can ultimately result in the "Results and Discussion" chapter, so there is compatibility. Moreover, the prospect of developing research results and application prospects of further studies into the next (based on results and discussion) can also be added.

Author Contribution: All authors contributed equally to the main contributor to this paper. All authors read and approved the final paper.

Acknowledgment: In this section, you can acknowledge any support not covered by the author's contribution or funding sections. This may include administrative and technical support or donations in kind (e.g., materials used for experiments).

Conflicts of Interest: Declare conflicts of interest or state, "The authors declare no conflict of interest."

References (Heading 5)

The references use the **IEEE style**. Cited references must be taken from the **journal**. Each should have a Digital Object Identifier (DOI) or permanent link. The references were published in the **last five years**. Please use reference management software such as Mendeley, Zotero, or EndNote. For journal references, please enlist the authors' names (First Name. Last Name), title, journal title, journal volume, article issue number, page number (pp.), published year, and DOI.

The template will number citations consecutively within brackets [1]. The sentence punctuation follows the bracket [2]. Refer simply to the reference number, as in [3]—**do not use** "Ref. [3]" or "reference [3]" except at the beginning of a sentence: "Reference [3] was the first ..." Do not use et al., write all of the author names. Some of the reference examples are

- [1] M. S. Apriantoro, M. N. I. Alis, S. Septianozakia, and D. Setiana, "Comparing KHI and KHES in Marital Property Grant Disputes: An Analysis of Judges' Views," *Al-Istinbath J. Huk. Islam*, vol. 8, no. 1 May, pp. 37–52, 2023.
- [2] M. S. Apriantoro and A. E. Nuraini, "Social network analysis of the development of the halal industry in Indonesia," *Bull. Soc. Informatics Theory Appl.*, vol. 6, no. 2, pp. 102–110, 2022.
- [3] N. Andriyani and M. S. Apriantoro, "Enhancing Students Cognitive Abilities in Integrated Islamic High Schools: A Need-Based Analysis for Developing Chemistry Modules Infused with Islamic Values," *ETHICA Int. J. Humanit. Soc. Sci. Stud.*, vol. 1, no. 1, pp. 1–10, 2023.