

University of Minnesota Nano Center

Keller Spinner CEE-3 (Apogee) - Standard Operating Procedure

Badger name:	K2 Spinner CEE3	Revision #:	0
Model:	200X	Revisionist:	Emma Jore
Location:	Keller-Bay 2	Date:	January 18, 2023

Table of contents

1. Introduction
2. Safety
3. Restrictions/Requirements
4. Required Facilities
5. Definitions
6. Process Button
7. Dispense
8. Operating Instructions
9. Problems/Troubleshooting
- 10.

University of Minnesota Nano Center

Keller Spinner CEE-3 (Apogee) - Standard Operating Procedure



1. Introduction

1.1. The Apogee CEE3 spinner is a PC-controlled spinner with a touch screen interface and display used for applying photoresist uniformly on a substrate.

1.2 It is equipped with the following:

- 1.2.1 Automated dispense for backside rinse
- 1.2.2 It is capable of spin speeds from 0 to 12,000 rpm and spin speed accelerations of 0 to 30,000 rpm/s. Spin speeds and time can be altered to achieve desired photoresist thickness.
- 1.2.3 Substrate size capability is from < 1cm to 200 mm round.
- 1.2.4 Vacuum and lid interlock
- 1.2.5 High-density polyethylene (HDPE) spin bowl for material compatibility

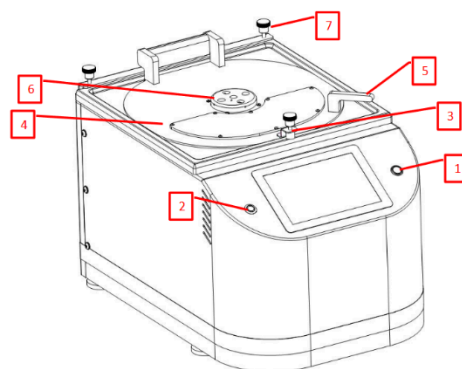

- 1. Power Button – Used to turn on and off the tool
- 2. User Presence Button – Used for remote access (see DataStream™ Manual)
- 3. Lid Sensor – Detects when the lid is closed
- 4. Spin Coater Lid – Cover for the spin bowl
- 5. Lid Handle – Used to open and close the lid
- 6. 5 - Hole Dispense Hub – Used to dispense material through
- 7. Lid Height Adjustment (3X) – Used to adjust airflow and solvent vapor in the spin bowl

University of Minnesota Nano Center

Keller Spinner CEE-3 (Apogee) - Standard Operating Procedure

2. Safety

- 2.1. For all chucks, ensure that the notch on the chuck is aligned to the drive pin on the spindle and push the chuck all the way down
- 2.2. Some chucks (6-inch) need to be secured with the vented screw (with hole in center) that has been tightened with the provided torque hex wrench.
- 2.3. Solvent filled canisters are pressurized. Do not attempt to refill them. Report empty canisters on Badger or to any MFC staff.

3. Restrictions/requirements

- 3.1. Must be a qualified user on the CEE-3 spinner
- 3.2. Use only resist or material approved for use in CEE-3 spinner. These are AZ1505, 1512, 1518, Shipley 1805, 1813, 1818, AZ 9260, SPR 220 7.0, SPR 955 0.7CM, Futurrex NR7-1500P, NR7-3000P, and any other materials approved by NFC staff. All dispensed materials are held in one common waste storage tank
- 3.3. Regularly used or **standard recipes are saved with 0_xxxx or 1_xxxx naming system**. These recipes will appear at the top of the list and no other recipe should precede them. Recipes that do not adhere to the above requirements will be deleted.
- 3.4. Maximum spin speed (12,000 rpm) or maximum acceleration (30,000 rpm per sec) should not be exceeded

4. Required facilities

- 4.1. Nitrogen or CDA (for automated dispense): 70psi
- 4.2. Voltage range: single phase 100 – 125VAC, 10amps, 50/60 Hz
- 4.3. Vacuum source: 20 - 25" Hg
- 4.4. Exhaust: 20 - 50 cfm at 0.2' water

5. Definitions

- 5.1. **Recipe Name:** The name of the currently loaded recipe
- 5.2. **Load:** Brings up the TODO Recipe Select Screen to select for processing
- 5.3. **Dispense:** Buttons which show which dispenses are currently activated
- 5.4. **Start Centering:** See below under **Process Button**
- 5.5. **Vacuum on/off:** this button allows the user to actuate the vacuum of the spin chuck as they center the substrate.
- 5.6. **Center:** Repeatable centering. Use this button to check centering at any time.

6. Process Button: This has four modes:

- 6.1. **Start Centering:** Starts the wafer spinning very slowly to check for centering on the spin chuck
- 6.2. **START:** Starts the selected process
- 6.3. **Abort:** Aborts a currently running process
- 6.4. **OK:** Turns off the process complete buzzer. Lifting up the lid does the same.
- 6.5. **Vacuum on/off button:** Allow users to actuate the vacuum of the spin-chuck as they center the substrate.

7. Dispense

- 7.1. If a recipe has the EBR or BSR step included, solvent will flow through the dispense nozzles during the dispense step and dispense buttons will be highlighted in green.

University of Minnesota Nano Center

Keller Spinner CEE-3 (Apogee) - Standard Operating Procedure

Both the backside rinse (BSR) and the edge bead removal (EBR) tanks are filled with EBR solvent.

- 7.2. The **EBR** and **BSR** dispense nozzles can be manually moved slightly to adjust aim on the wafer so that fluid is directed at the wafer edge. Pressure at the dispense nozzles is managed from the dispense control box, and has been adjusted to minimize flow volumes.
- 7.3. MNC staff manage refill of the pressurized canisters. Should solvent run out please inform MFC staff.

8. Operating instructions

8.1. Log into Badger and enable K2 Spinner CEE3

8.2. If you need to login tap the **Login** button on the top right of the screen. Enter Username "oper" and password "1234"

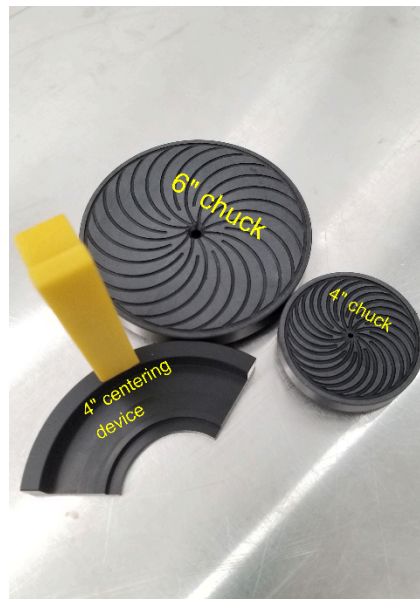
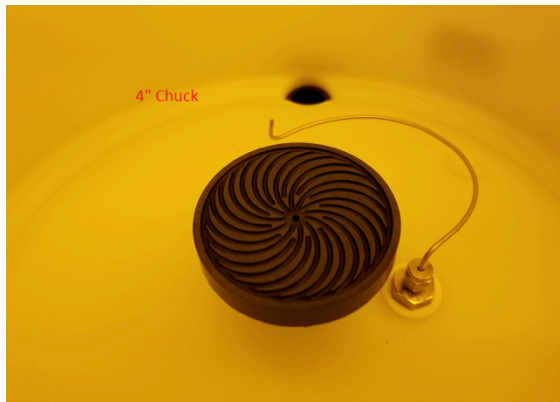

8.4 Push **LOAD RECIPE**. Alternately, on the top row, push on "**Recipes**" to bring up the recipes menu.

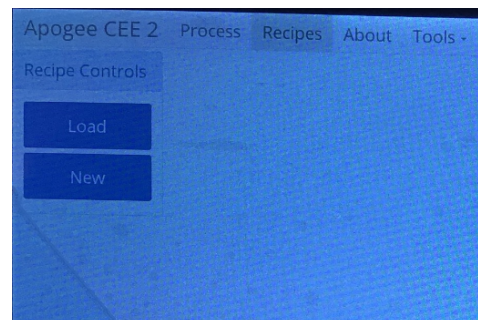
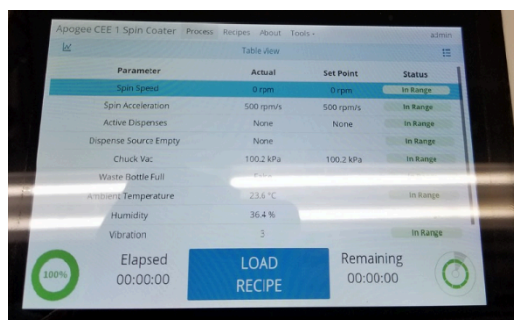

University of Minnesota Nano Center

Keller Spinner CEE-3 (Apogee) - Standard Operating Procedure

8.5 Push load and select the recipe you want to run. Most frequently used recipes will appear at the beginning.

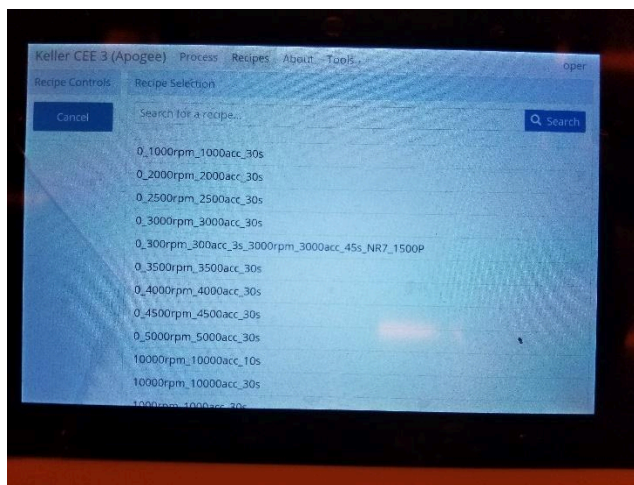

8.6 Select recipe and press the **Run** to bring up the spin process window

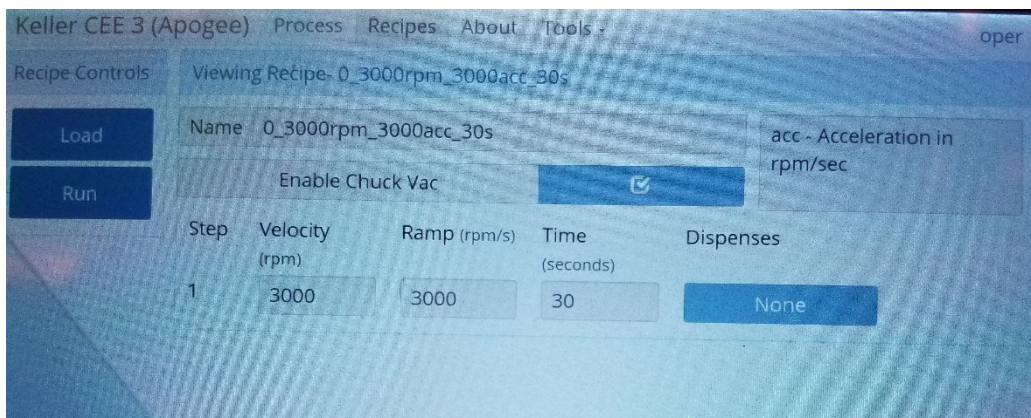

8.7 On the Process window, press START

University of Minnesota Nano Center

Keller Spinner CEE-3 (Apogee) - Standard Operating Procedure

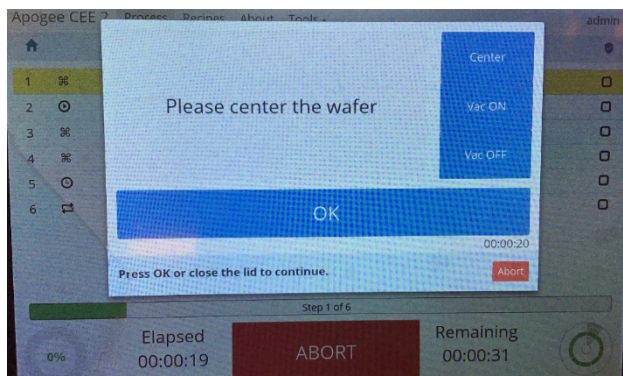

8.8 Load a wafer on the chuck and push **Vac ON** (substrate should fully cover all chuck surface). Press **Center** and check for wobbliness. If wafer wobbles, release vacuum (Vac OFF) and re-center using centering device.

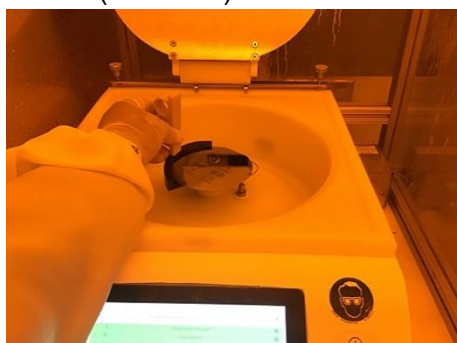

8.9 Dispense the desired amount of photoresist onto the center of the substrate. Close the lid.
NB if the waste drain bottle is full, you will not be able to run any process until the waste bottle is emptied.

University of Minnesota Nano Center

Keller Spinner CEE-3 (Apogee) - Standard Operating Procedure

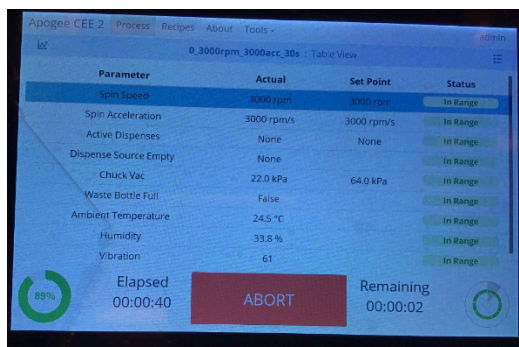

8.10. Process Complete: Once the process is completed, an audible alarm may sound. Pressing the **OK** button or lifting the will silence the alarm

8.11. Clean the spinner bowl lining using acetone and cleanroom wipes until there is no residual photoresist. Excess solvent will drain to the waste bottle via a drain hole below the chuck. Do not spray acetone on the chuck center where the screw is as this may ruin the motor.

9. Problems/troubleshooting

9.11. Wafer does not spin after closing the lid: potential problems include tool not enabled on badger or vacuum lost during spin. If the later, inform staff.