

ANDE summit (student lessons)



To create your own copy of this file, click "File>Make a local copy." This saves a copy of the file to your own account.



Complete Lessons Pack - Student

Table of contents:

- ❖ [Lesson D1: The Center and Shape of a Data Distribution](#)
- ❖ [Lesson D2: Measuring Variability in a Data Distribution](#)
- ❖ [Lesson D3: Examining Outliers in a Data Distribution](#)
- ❖ [Lesson D4: Problem Solving with Angles](#)
- ❖ [Lesson D5: Perimeter and Area](#)
- ❖ [Lesson D6: Problem Solving with Surface Area](#)
- ❖ [Lesson D7: Problem Solving with Volume](#)

The Center and Shape of a Data Distribution

What is a Typical Value?



Learning Goals

After this lesson, you should understand

- the mean and median can be used to describe the center of a data distribution.
- a data distribution has a center and shape.
- the shape of a data distribution impacts whether the mean or median is a better measure of the center.

After this lesson, you should be able to

- determine the shape of a data distribution.
- find the mean, median, and mode of a data set.
- determine which measure of center (mean or median) is most appropriate for the data set.
- use a line plot or histogram to answer questions about a quantitative variable.



The Center of a Data Distribution

Kyle is an avid coffee drinker and wants to know if the amount of coffee that he consumes on a daily basis is typical of adults in his workplace. Kyle drinks about 3 cups of coffee every day. He decides to collect some data, and randomly selects people at his job and asks them how many cups of coffee they drink each day. The table below summarizes the results.

Table: Cups of Coffee Per Day

| | | | | |
|---|---|---|---|---|
| 0 | 0 | 0 | 1 | 1 |
| 2 | 2 | 1 | 1 | 1 |
| 2 | 3 | 3 | 4 | 7 |

- (Q1)** Create a line plot of the values on the graph. Plot a dot above the number line for each value. If a value occurs more than once, plot multiple dots above the position on the number line.

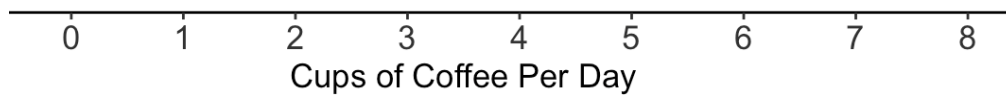

- (Q2)** Based on the line plot, what number is a good estimate for the *center* of the data distribution? The center of the data values is a value that describes the middle of the data values. In other words, what is the typical number of cups of coffee that people consume each day at Kyle's workplace?

There are three numerical summaries of quantitative data that describe the center of a data set.

Mean - The mean of a data set is the arithmetic average of the values in the data set. To calculate the mean, we find the sum of the values and divide the sum by the number of values.

Median - The median of a data set is the number in the middle position, when the data are ordered from least to greatest. When the data set has an odd number of values, there is a number in the middle position. When a data set has an even number of values, there are two middle numbers, and the median is the average of the middle two numbers.

Mode - The mode of a data set is the value in the data set that occurs the most number of times.

(Q3) Find the mean, median and mode of the data set above. Round the mean to one decimal place.

(Q4) Can you think of a reason why the mean is greater than the median? Consider how each measure of center is determined.

(Q5) Kyle consumes 3 cups of coffee per day? How does Kyle's daily coffee consumption compare to the center of the data distribution?



Shapes of Distributions

Data distributions can have a variety of shapes. The shape of a distribution is a description of the overall pattern of the distribution. The common shapes which we will explore are bell-shaped, skewed left, and skewed right.

Bell-shaped

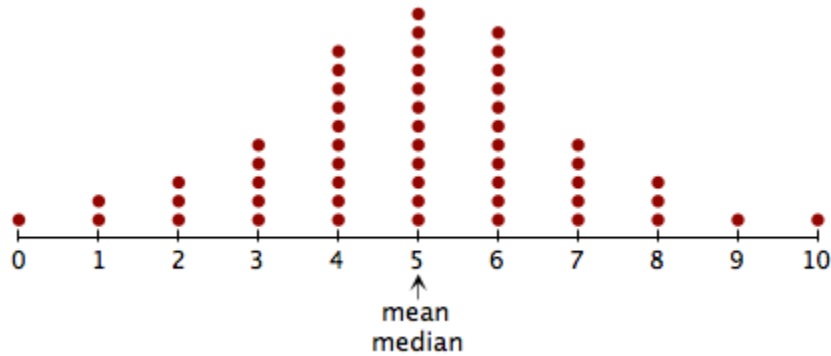

In a bell-shaped distribution, the mean and median are very similar and are close to the middle of the distribution. The number of data values less than the mean is similar to the number of data values greater than the mean. The distribution is also approximately symmetric, so the left and right sides will resemble mirror images.

Skewed to the Right Distribution

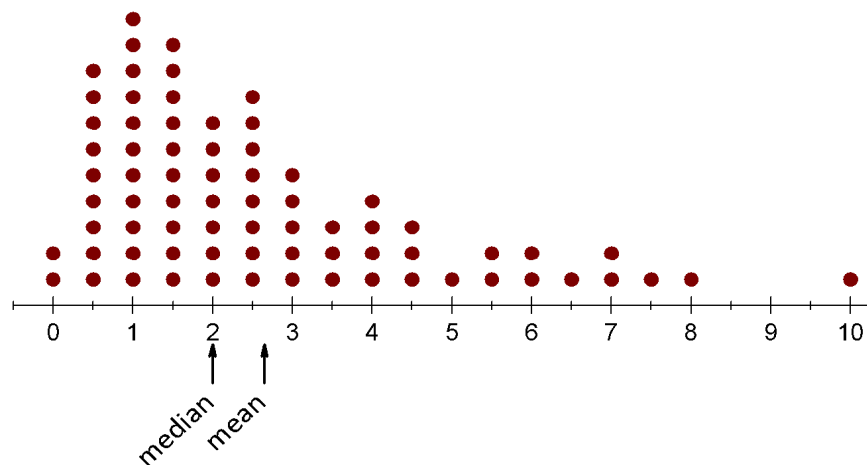

When data are skewed to the right, the right side trails off and is more spread out than the left side, and we say that the right “tail” is longer than the left “tail.” When

this occurs, the mean is pulled towards the right tail, and the mean tends to be greater than the median.

Skewed to the Left Distribution

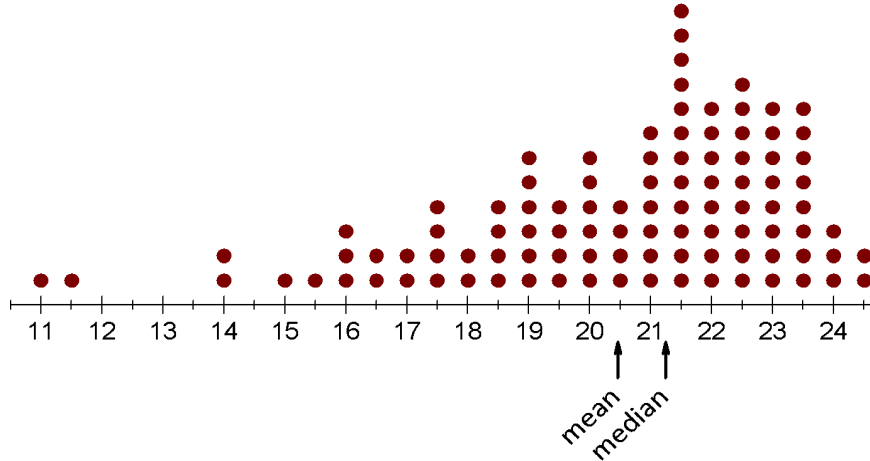

When data are skewed to the left, the left side trails off and is more spread out than the right side, and we say that the left “tail” is longer than the right “tail.” When this occurs, the mean is pulled towards the left tail, and the mean tends to be less than the median.

Relationship between Shape and Measure of Center

When data are skewed (to the right, or to the left) the median is a better measure of the center than the mean. The median is found from the middle value (or middle values) in the data set, and is not impacted by extreme values (really low values or really high values). The mean, however, is impacted by these extreme values. These extreme values cause the mean to move away from the middle of the distribution.



Created by [Brittany Hejira](#)
from the [Noun Project](#)

- (Q6)** Kevin collects stamps and is interested in the typical age of the stamps in his collection. The line plot below contains the ages of the stamps in the collection.

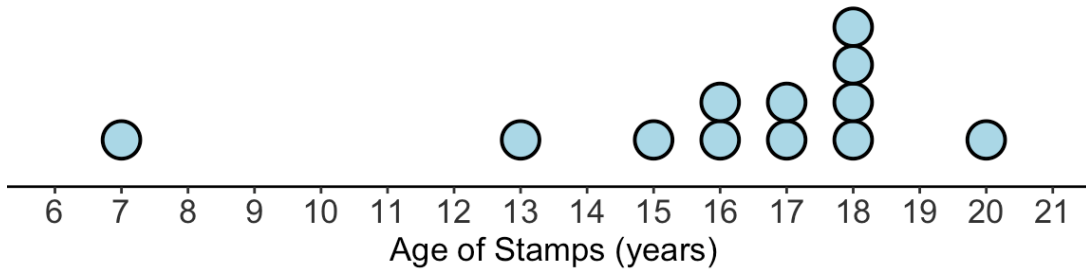

- How many observations are in the data set?
- What is the unit of measurement of the quantitative variable?
- What is the shape of the distribution?
- Determine the mean, median, and mode. Round the mean to one decimal place.

(e) Which measure of center, mean or median, is most appropriate for describing the typical age of a stamp in the collection. Why?

(Q7) Scientists record the monthly temperature of regions throughout the world to examine how the temperatures across the globe change over time. A *monthly temperature* of a region is the average temperature of a region during the month. June monthly temperatures (in degrees Fahrenheit) of the state of Pennsylvania are summarized in the histogram below. The number above the bar indicates the number of observations in the corresponding bin. Each bin excludes the starting value but includes the end value. For example, the range of the first bin is $62 < x \leq 63$. This means that there are 6 temperatures greater than 62 but less than or equal to 63. Each bin has a width of 1.

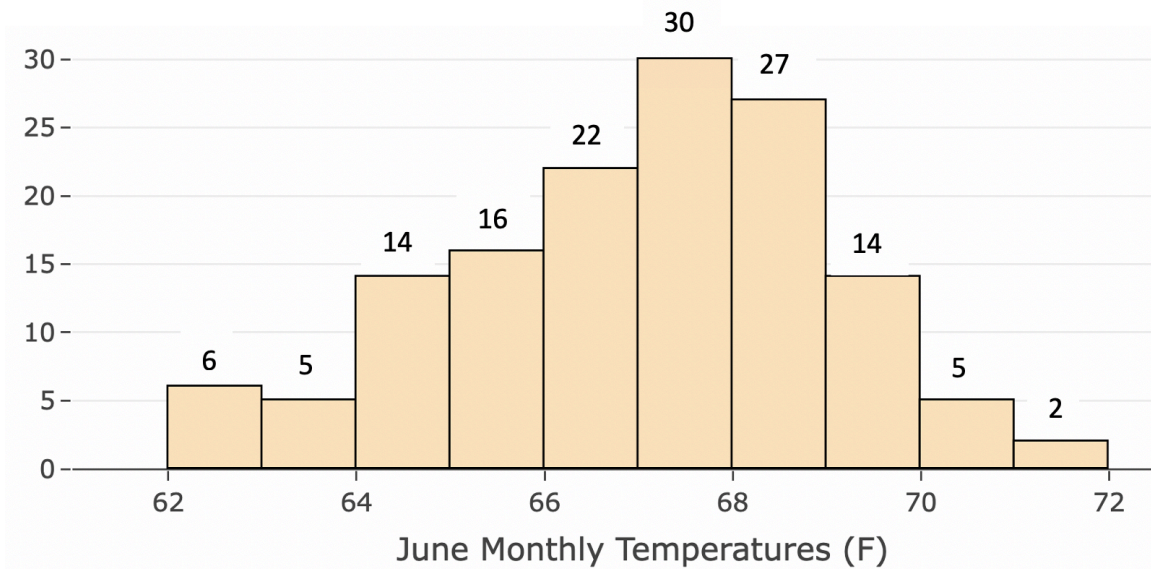

(a) How many observations are in the data set?

(b) What is the unit of measurement of the quantitative variable?

(c) What is the shape of the distribution?

(d) The mean of the June monthly temperatures is 67 degrees Fahrenheit and the median is 67.2 degrees Fahrenheit. Which statement below helps explain why these values are so close?

- The mean and median both use all of the data values in the data distribution.
- The mean is similar to the median because the data is approximately bell-shaped.
- The mean is similar to the median because there are many observations in the data set.
- The number of low monthly temperatures is much greater than the number of high monthly temperatures.

(e) Use the histogram to determine the percentage of June monthly temperatures that are greater than 70 degrees Fahrenheit. Assume that the bars that are to the right of 70 contain June monthly temperatures that are greater than 70 degrees Fahrenheit.

- (f) In June 2010, the June monthly temperature in Pennsylvania was 70.4 degrees Fahrenheit. Is this monthly temperature a typical monthly temperature in this distribution? Or, is 70.4 degrees Fahrenheit unusual? Explain.



Created by Claire Jones
from the Noun Project



Created by bintang kejora
from the Noun Project



Created by Adrien Coquet
from the Noun Project

Closing Reflections

Please discuss the following questions with your partner or in your small group:

- Why is it helpful to identify the center of a data distribution?
- Why is the median a better measure of center than the mean when the data distribution is skewed?

Measuring Variability in a Data Distribution

What is an Outlier?



Learning Goals

After this lesson, you should understand

- the range and interquartile range can be used to describe the variability of a data set.
- the interquartile range can be used to identify outliers in a data set.
- stacked box plots allow us to compare two data distributions.

After this lesson, you should be able to

- compute and interpret the range and interquartile range of a data set.
- use the interquartile range to classify data values as outliers.
- interpret a stacked box plot and compare distributions.



Created by [Sintia Hejira](#)
from [The Noun Project](#)

Making Sense of Data

Maria enjoys eating healthy breakfast cereals and she gives breakfast cereals to her kids. She is interested in examining if the sugar content in popular breakfast cereals for children is different from the sugar content in popular breakfast cereals for adults. She collects data from a sample of popular cereals for adults and children.

The table below contains the sugar amount per serving for 10 adult cereals.

| Adult Cereals | Amount of sugar per serving (grams) |
|--|--|
| All-Bran | 5 |
| All-Bran with Extra Fiber | 0 |
| Corn Chex | 3 |
| Corn Flakes | 2 |
| Crispy Wheat & Raisins | 10 |
| Fruit & Fiber Dates, Walnuts, and Oats | 10 |
| Grape Nuts Flakes | 5 |
| Grape-Nuts | 3 |
| Great Grains Pecan | 4 |
| Nutri-Grain Almond-Raisin | 7 |

- (Q1)** Determine the 5-number summary for the sugar amounts in the adult cereals. Complete the table below.

Adult Cereals: Amount of sugar per serving (grams)

| | |
|----------------------------|--|
| Minimum | |
| Q1 (first quartile) | |
| Median | |
| Q3 (third quartile) | |
| Maximum | |

(Q2) A **box plot** shows the locations of the values in the five-number summary. The quartiles are displayed in the box. The median (Q_2) is located at the vertical line inside the box. An example is shown below. The box plot summarizes the sodium content (in milligrams) of 20 breakfast cereals.

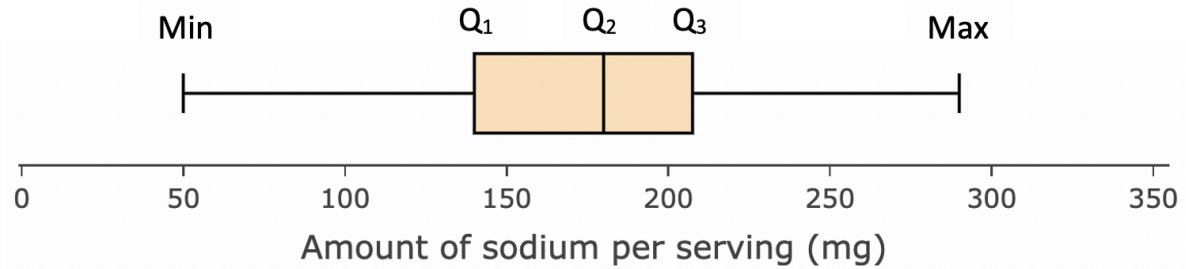

Draw a box plot of the sugar amounts in the adult cereals. Draw the box plot above the number line below.

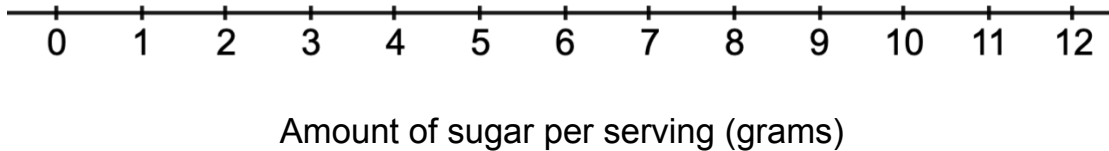

(Q3) The **range** is the distance between the minimum value and the maximum value. The range is the distance that captures 100% of the data values. What is the range?

(Q4) The **interquartile range (IQR)** is the distance between the first quartile (Q_1) and the third quartile (Q_3). **$IQR = Q_3 - Q_1$** . The interquartile range is the range of middle 50% of the data values. What is the interquartile range?

- (Q5)** Which data values in the data set are within $Q1$ and $Q3$? These are the values that are within the middle 50% of the data set?



Created by Adrian Cooper
From the News Project

Classifying Outliers

An **outlier** is a value that is much greater than or less than the rest of the values in the data set. One common rule for defining outliers is based on the IQR (the interquartile range). Outliers are data values that are more than 1.5 IQRs below $Q1$, or more than 1.5 IQRs above $Q3$.

So, a data value is an outlier if it is:

$$\text{Less than } Q1 - 1.5(IQR) \quad \text{or} \quad \text{Greater than } Q3 + 1.5(IQR)$$

These values are called the **fences** for outliers.

- (Q6)** Calculate the **lower fence** for the sugar amounts in the adult cereals. Are there any data values less than the lower fence? Discuss with your partner or in your small group.
- (Q7)** Calculate the **upper fence** for the sugar amounts in the adult cereals. Are there any data values greater than the upper fence? Discuss with your partner or in your small group.

A **stacked box plot** is a graph that shows box plots from multiple groups. The stacked box plot below compares the sugar amounts per serving for cereals popular with adults and cereals popular with children.

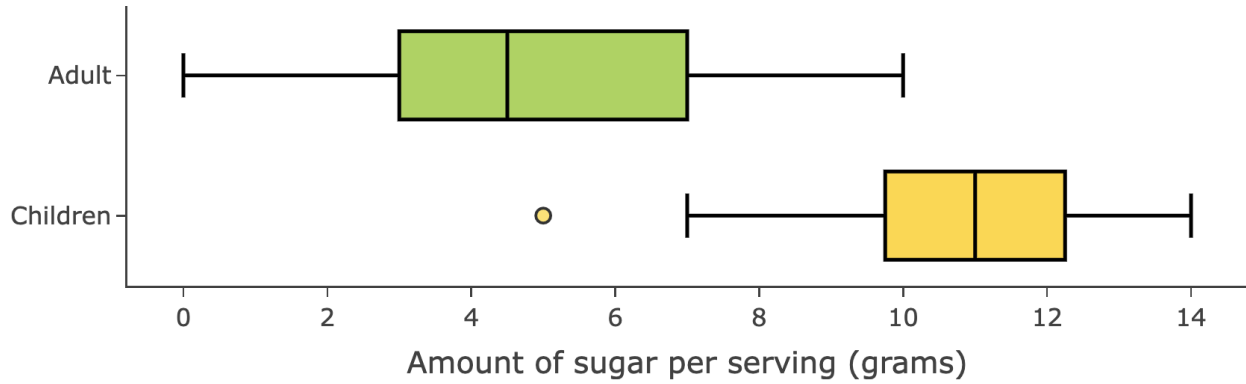

The table below provides the five-number summary for 13 popular children cereals.

Children’s Cereals: Amount of sugar per serving (grams)

| | |
|----------------------------|------|
| Minimum | 5 |
| Q1 (first quartile) | 9.75 |
| Median | 11 |
| Q3 (third quartile) | 12.2 |
| Maximum | 14 |

Use the stacked box plot and the table above to answer the questions below.

(Q8) What is the range and interquartile range of the sugar amounts in the children cereals? The dot in the children cereals’ box plot shows the location of the minimum value.

(Q9) The box plot also shows that the minimum sugar amount in the children cereals is an outlier. Outliers are represented as dots. Calculate the lower fence of the sugar amounts in the children cereals to show that the data value of 5 grams is an outlier.

(Q10) Which cereal type (adult or children) has more variability in the sugar amounts? In other words, which cereal type has sugar amounts that are more spread out from the median? Use the box plots to explain your answer. Try to provide at least two justifications. Include the unit of measurement.

(Q11) On average, which cereal type (adult or children) contains more sugar? Use the box plots to explain your answer. Try to provide at least two justifications. Include the unit of measurement.

(Q12) Maria decided to examine the difference in protein amounts for children cereals and adult cereals. Using the same cereals as above, she created a stacked box plot to compare the protein amounts per serving for the two groups of cereal. Use the stacked box plots below to compare the two data distributions.

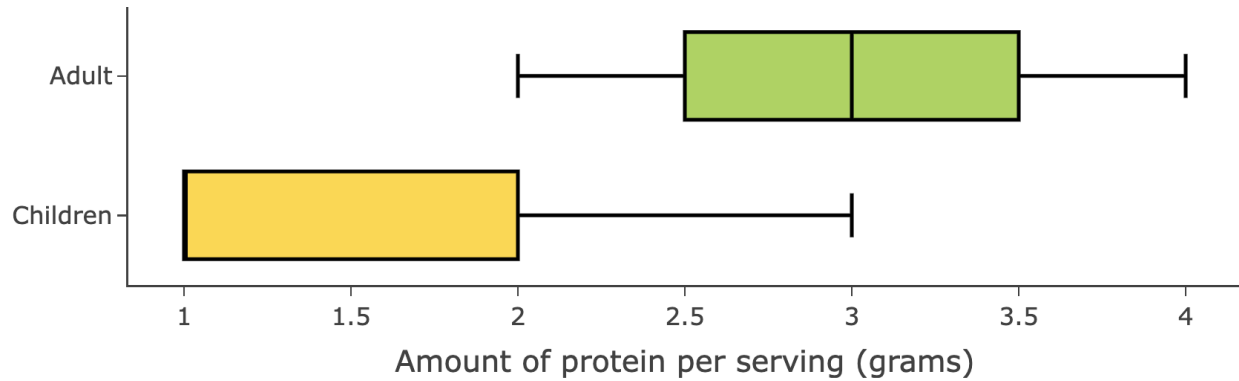

(a) On average, which cereal type (adult or children) has more protein? Use the stacked box plot to explain your answer.

(b) Which cereal type has more variability in the protein amounts? Use the stacked box plot to explain your answer.



Created by Claire Jones
From the Noun Project



Created by Iñaki Jorjón
From the Noun Project



Created by Adrien Coquet
From the Noun Project

Closing Reflections

Please discuss the following questions with your partner or in your small group:

- What does variability in data mean?
- How does the interquartile range (IQR) allow us to measure the variability of a data distribution?
- How do stacked box plots allow us to compare two data distributions?

Examining Outliers in a Data Distribution

Choosing the Best Measure of Variability



Learning Goals

After this lesson, you should understand

- the mean absolute deviation can be used to describe variability of a data set.
- the mean absolute deviation can be used to identify outliers in a data set.

After this lesson, you should be able to

- interpret the mean absolute deviation.
- use the mean absolute deviation to classify data values as outliers.
- decide which measures of center and variability to use to describe a data set based on the shape of a data set.



What Value is Unusual?

Ben goes to the gym each week to work out, and he typically spends 7 hours per week at the gym. He is interested in finding out whether the amount of time that he spends at the gym each week is typical when compared to the other gym customers. He surveyed 42 people who attend the gym regularly and collected data on the number of hours per week that they work out. The line plot below summarizes the data values.

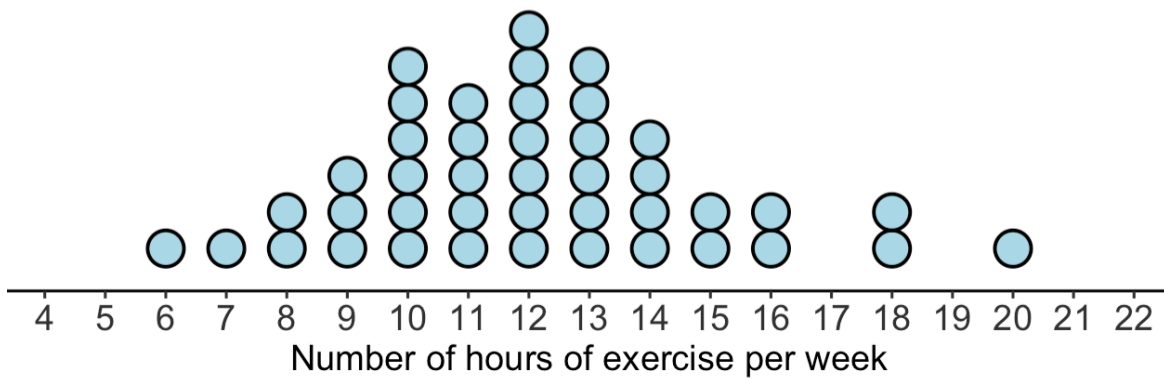

(Q1) Describe the shape and center of the distribution? Do any values appear to be unusual?

(Q2) We can use the **mean absolute deviation** (MAD) to examine how values in the distribution vary from the mean. Let's first compute deviations from the mean of a few data values. The distribution has a **mean** of **12.1 hours**. What are the deviations from the mean of the following data values?

(a) 8 hours

(b) 10 hours

(c) 14 hours

(d) 18 hours

(Q3) The distribution has a mean of **12.1 hours** and a mean absolute deviation (MAD) of **2.2 hours**. Interpret the mean absolute deviation. What does the mean absolute deviation tell us about this data distribution?



Created by Adrienne Cooper
From the Moon Project

Classifying Outliers using Mean Absolute Deviation

There are many rules for classifying outliers. In any data distribution, about 95% of the data values will be within 2.5 mean absolute deviations from the mean. So, if a value is more than 2.5 mean absolute deviations away from the mean, we can consider it an outlier. When this happens, the data value is outside the middle 95% of the data values. This makes the value very unusual.

So, a data value is an outlier if it is:

Less than $\text{Mean} - 2.5(\text{MAD})$ or Greater than $\text{Mean} + 2.5(\text{MAD})$

(Q4) Let's find these values to classify outliers.

(a) Determine the position: $\text{Mean} - 2.5(\text{MAD})$

(b) Determine the position: $\text{Mean} + 2.5(\text{MAD})$

(c) What percentage of data values in the distribution are within 2.5 mean absolute deviations from the mean? Use the line plot to determine the percentage. Round to the nearest percent.

(d) What percentage of data values in the distribution are more than 2.5 mean absolute deviations away from the mean?

(Q5) What data values are more than 2.5 mean absolute deviations away from the mean? These are the outliers? Is Ben's value of 7 hours an outlier? Discuss with your partner or in your small group.



Created by Bintang Sejora
from the Moon Project

Which Measure of Variability is Most Appropriate?

The shape of a data distribution impacts which measure of center and measure of variability should be used to describe the data and classify outliers.

- When a data distribution has a skewed shape, the median is a preferred measure of center. Since the interquartile range (IQR) is based on the median, the IQR should be used to describe variability and classify outliers.
- When a data distribution is bell-shaped, the mean is a preferred measure of center. Since the mean absolute deviation (MAD) is based on the mean, the MAD should be used to describe variability and classify outliers.

(Q6) Ben asked customers at the gym to estimate the amount of money that they spend on nutritional supplements (pre- and post- workout drinks and food) each week. The histogram summarizes the 42 data values.

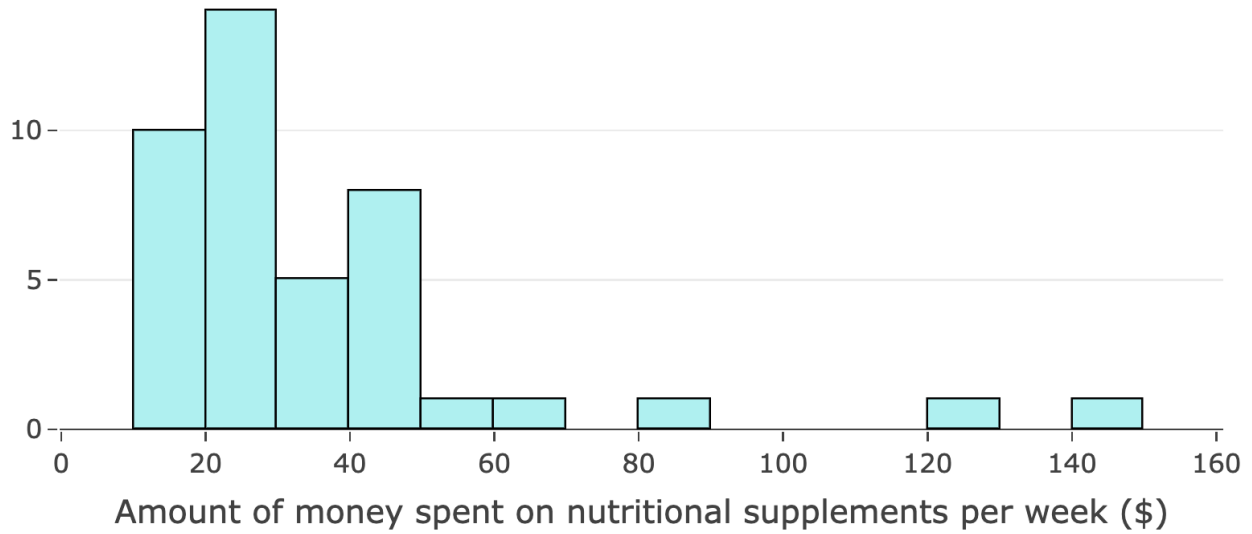

The 5-number summary, mean, and mean absolute deviation of the distribution are provided below.

Amount of money spent per week on nutritional supplements (\$)

| | |
|--------------------------------|------|
| Minimum | 12 |
| Q1 (first quartile) | 20 |
| Median | 28.5 |
| Q3 (third quartile) | 42 |
| Maximum | 145 |
| Mean | 36.2 |
| Mean Absolute Deviation | 17.1 |

(a) Interpret the mean absolute deviation.

(b) Find the interquartile range (IQR). What does the IQR tell us?

(c) Which measures of center and variability should be used to describe the data set, and why?

(d) Use the appropriate measure of center and variability to determine if there are any outliers in the data set? What do you notice about the outliers?



Created by Claire Jones
from the Noun Project



Created by hinkang kelora
from the Noun Project



Created by Adrien Coquet
from the Noun Project

Closing Reflections

Please discuss the following questions with your partner or in your small group:

- What does it mean for a data value to have a deviation from the mean?
- What is the mean absolute deviation of a data set? Why is it useful?
- Why is it helpful to have multiple ways to classify outliers?

Problem Solving with Angles

Using Angles in Quadrilaterals



Learning Goals

After this lesson, you should understand that

- a quadrilateral is a two-dimensional figure with four sides.
- the sum of the interior angles of a quadrilateral is 360° .
- the sum of the interior angles of a triangle is 180° .
- we can solve for unknown angles when given information about a quadrilateral.

After this lesson, you should be able to

- use properties of angles and two-dimensional shapes to solve problems.



Created by [Birthing Ideas](#)
from [The Noun Project](#)

What Shape Looks the Best

Lisa is creating a large wooden picture frame for a group of family pictures. The outside of the picture frame will be made from four pieces of wood: two pieces of length 3 feet, and two pieces of length 5 feet.

(Q1) Draw three different ways in which Lisa can use the wooden pieces to create a picture frame. Label the sides with the corresponding lengths. What shapes are possible?

(Q2) Which shape do you think is most appealing to use for a picture frame, and why?



Angles in Quadrilaterals

Each figure above is a **quadrilateral**. A quadrilateral is a two-dimensional figure with four sides, and the **sum of the four interior angles is 360°** . When a quadrilateral consists of **two pairs of equal-length sides**, the quadrilateral is a parallelogram or a kite. A rectangle is a parallelogram containing four right angles (90° angles).

The properties of parallelograms and rectangles are shown below.

Parallelogram

- Opposite sides are parallel (Side AD is parallel to BC; side AB is parallel to DC)
- Opposite sides have the same length ($AD = BC$, $AB = DC$)
- Opposite interior angles are equal ($a = c$, $b = d$)
- Consecutive angles (angles that follow each other) are supplementary (a and d , d and c , c and b , b and a)

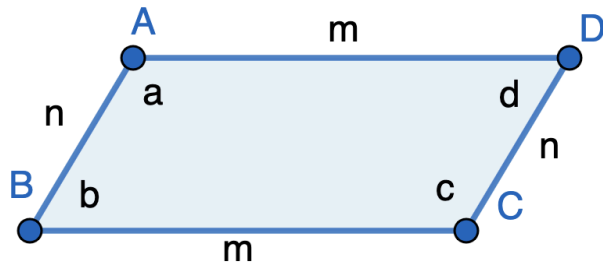

Rectangle

- Opposite sides are parallel (Side AD is parallel to BC; side AB is parallel to DC)
- Opposite sides have the same length ($AD = BC$, $AB = DC$)
- All four interior angles are 90°

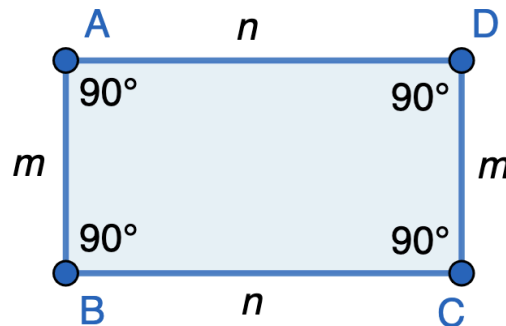

(Q3) In the problems below, find the missing angles of the quadrilateral. First classify the quadrilateral as a parallelogram or rectangle. For each figure, explain how you can determine the missing angles. The lengths of the sides are provided.

(a)

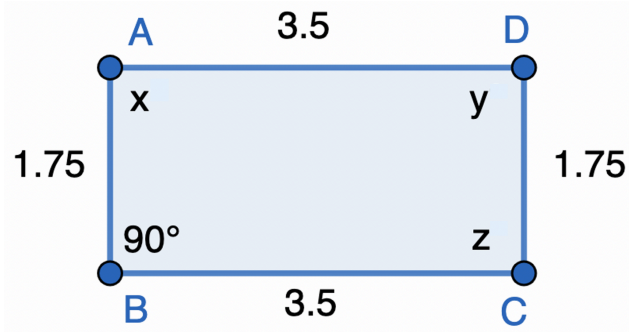

(b)

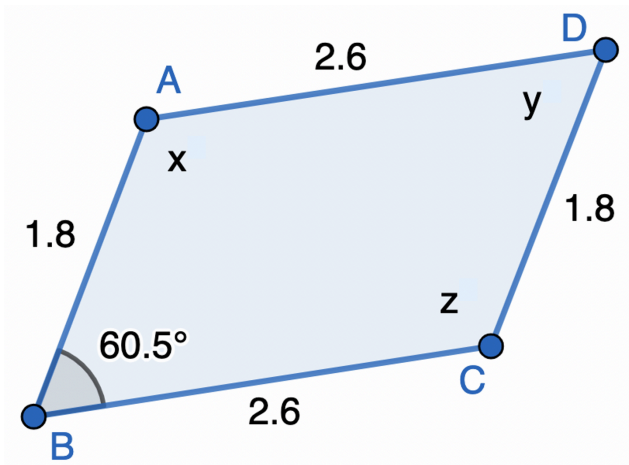



Angles in Triangles

A triangle is a two-dimensional figure with three sides, and the **sum of the three interior angles is 180°** . The figure below shows a triangle with three angles and three sides labeled.

(Q4) Explain how you can find the unknown angle in each triangle below, and find the missing angle(s).

(a)

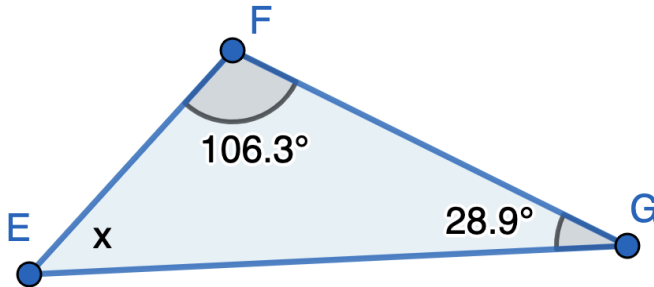

(b)

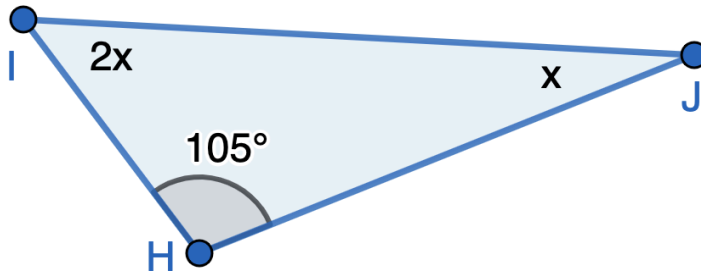



Created by [Brittany Hejira](#)
from [The Noun Project](#)

The following diagrams show the intersection of two or more lines.

- Specify angles that are complementary, supplementary, or vertical. You do not have to list all possible pairs.
- Create equations to describe the relationship between the unknown angles.
- Find the values of the unknown angles.

(Q5) Two lines intersect at a common point.

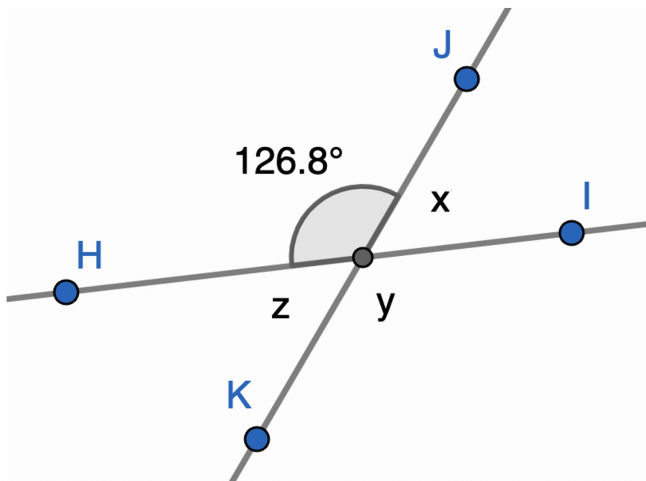

(Q6) Three lines intersect at a common point.

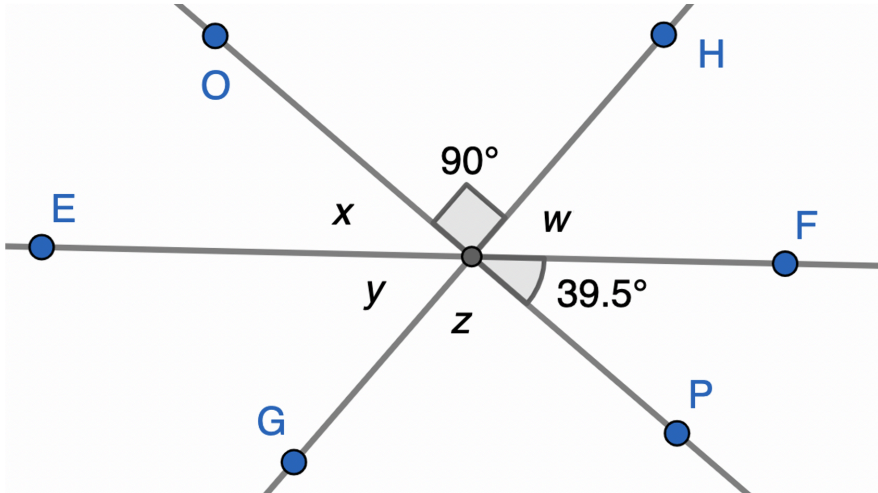

(Q7) Two lines intersect at a common point.

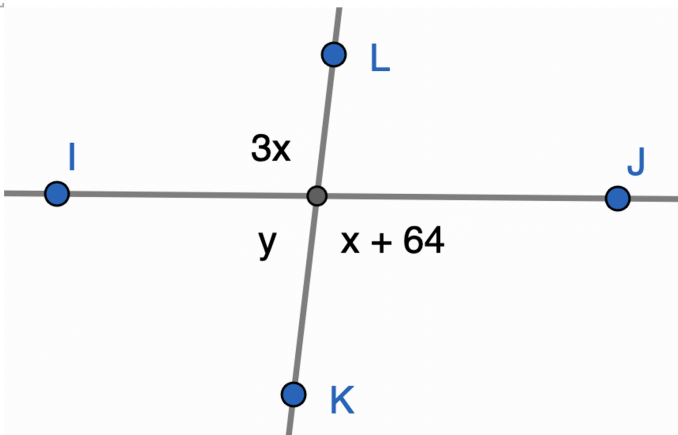



Created by Claire Jones
from the Noun Project



Created by Irling Jodra
from the Noun Project



Created by Adrien Coquet
from the Noun Project

Closing Reflections

Please discuss the following questions with your partner or in your small group:

- What is the difference between complementary angles, supplementary angles and vertical angles?
- What do all quadrilaterals have in common?

Perimeter and Area

Applications of Perimeter and Area



Created by Claire Jones
from the Neuen Project

Learning Goals

After this lesson, you should understand that

- the perimeter of a two-dimensional figure is the length of the boundary around the figure.
- perimeter is measured in linear units.
- the area of a two-dimensional figure is the amount of space inside the figure.
- area is measured in square units.

After this lesson, you should be able to

- find the perimeter and area of a rectangle and triangle given the side lengths.
- find the length or width of a rectangle given its perimeter.
- find the length or width of a rectangle given its area.



Created by Adrian Coggett
From the Noun Project



Created by Irlinang Isjora
From the Noun Project

Room Makeover

Amy is renovating her basement by updating the wall paint, trim, and carpet. The basement has the shape shown below.

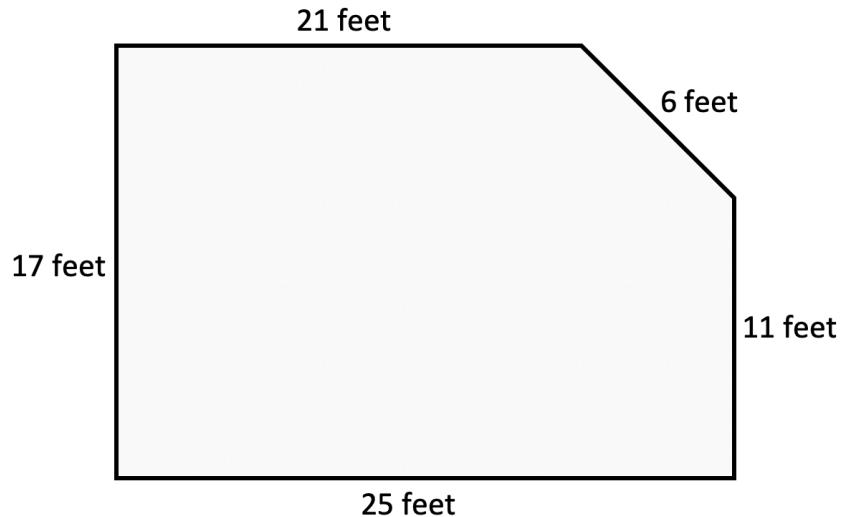

(Q1) Amy is installing trim around the border of the room. The cost of the trim is \$3.89 per foot. Amy decides to purchase 10% more trim than is needed for the border of the room. What is the cost of the trim?

(Q2) Amy's friend asserts that the trim around the room should be measured in square feet. Why is her friend incorrect? How would you explain to Amy's friend the unit of measure for the trim around the room?

(Q3) What is the area of the room? How can we break up the space in the room to find the area?

(Q4) The carpet which Amy is installing costs \$3.32 per square foot. The store sells the carpet in rolls that are of width of 12 feet, 13.5 feet, or 15 feet. The roll of carpet can be cut to any length. How should the carpet be purchased, and what will be the cost of the carpet? Discuss in pairs or in your small group before recording your thinking below.

(Q5) The ceiling in the basement is 8 feet tall. What is the area of the walls?



Created by [Brittany Hejira](#)
from [The Noun Project](#)

Finding the Dimensions of a Room

Amy is building a small closet in the basement. She wants the closet floor to have an area of 40 square feet with a perimeter of 26 feet.

- (Q6)** There are several combinations of length and width which will result in an area of 40 square feet. Complete the table below. For each value of the length, find the corresponding width and the perimeter of the room.

| Length | Width | Perimeter |
|----------|-------|-----------|
| 3.2 feet | | |
| 4 feet | | |
| 6.4 feet | | |

- (Q7)** Which dimensions (length and width) in the table above result in a perimeter closest to 26 feet?

- (Q8)** Which dimensions (length and width) result in a perimeter of exactly 26 feet?

Finding the Dimensions given the Perimeter

(Q9) A rectangle has a length of 8 feet and a perimeter of 40 feet. What is the width of the rectangle?



Created by Claire Jones
from the Noun Project



Created by bintang kejora
from the Noun Project



Created by Adrian Coquet
from the Noun Project

Closing Reflections

Please discuss the following questions with your partner or in your small group:

- What is the difference between perimeter and area?
- Why is the area of a figure measured in square units?

Problem Solving with Surface Area

Surface Area in the Real-World



Learning Goals

After this lesson, you should understand that

- a triangular prism is a three-dimensional object that has five faces in which three faces are rectangles and two faces are triangles.
- the faces of a triangular prism can be displayed using a net diagram.
- the surface area of a triangular prism is the sum of the areas of the faces.

After this lesson, you should be able to

- draw the net diagram of a triangular prism.
- calculate the surface area of a triangular prism.
- use surface areas to solve real-world problems.



Created by Adrian Coquet
from the Noun Project



Created by Iñaki Lejona
from the Noun Project

Estimating Construction Costs

John is placing insulation in his attic and needs to estimate the cost. His attic has the shape of a triangular prism, as shown below. A triangular prism is a three-dimensional object with five faces. It has two opposite faces that are triangles, and three faces that are rectangles.

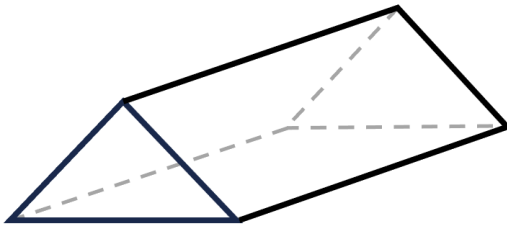

- (Q1)** To find the surface area of a triangular prism, we must find the areas of triangles and rectangles. What is the formula for the area of a rectangle? What is the formula for the area of a triangle?

- (Q2) The attic is represented by the diagram below. The lengths of the sides are listed below. **Draw a net diagram** to represent the faces of the attic. **Label the sides of the net diagram** with measurements, and indicate which face is the floor. The perpendicular height is the distance from the floor to the top of the attic.

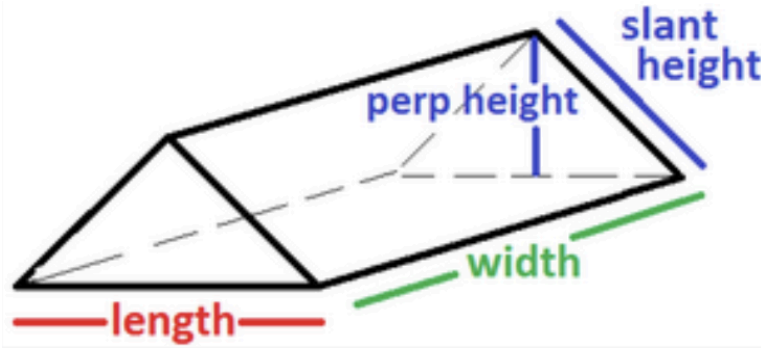

Length = 16 feet

Width = 38 feet

Perpendicular height
= 12 feet

Slant height = 14.4 feet

- (Q3)** John is placing insulation on the inside of every surface of the attic, including the floor. What is the total surface area of the attic? The surface area is measured in square feet. Work in pairs or in your small group to calculate the total surface area.
- (Q4)** The insulation and materials used on the floor of the attic costs \$1.95 per square foot. What is the cost of the materials and insulation for the floor of the attic?
- (Q5)** The insulation and materials used on the walls and ceilings of the attic costs \$2.30 per square foot. What is the cost of the materials and insulation for the walls and ceilings of the attic?

- (Q6)** The net diagram below represents the attic of John's cousin, Casey. Use the net diagram to **estimate the insulation costs** for Casey's attic. At Casey's home, the insulation and materials for the floor of the attic costs \$2.25 per square foot, and the insulation and materials for the walls and ceilings of the attic costs \$2.78 per square foot. Round the areas and costs to two decimal places.

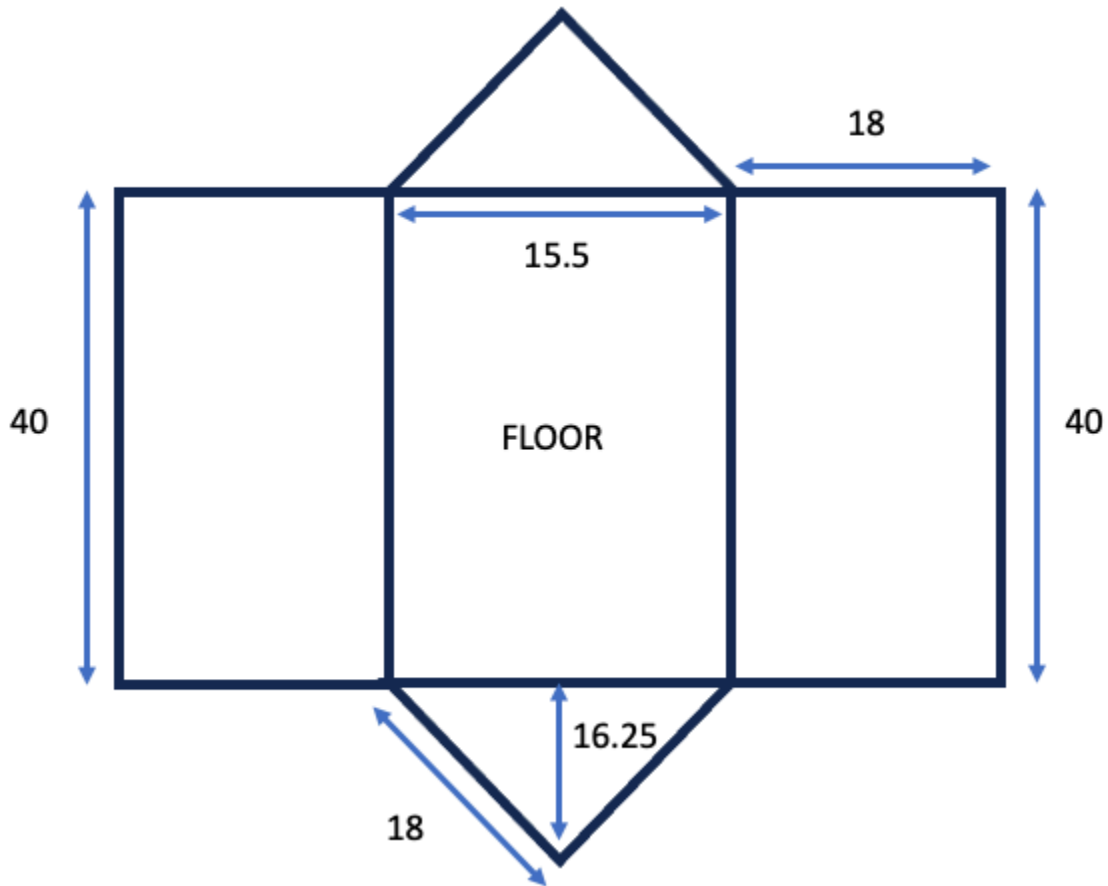



Created by Adrian Coquet
From the Noun Project



Created by Jintana Kejara
From the Noun Project

Surface Area of a Triangular House



- (Q7)** The length of the house is 22 feet, the width of the house is 14.5 feet, the perpendicular height is 20 feet, and the slant height is 22.8 feet. What is the surface area of the house, including the floor?
- (Q8)** The roofing materials cost \$7.30 per square foot. Based on experience, a contractor decides to purchase 10% more material. Extra materials are needed due to the cuts that will be made to install the roofing materials. What is the materials cost for the roof? Round the area of the roof to the nearest whole number, and round the materials cost to the nearest whole number.



Created by Claire Jones
from the Noun Project



Created by Iain King Lejora
from the Noun Project



Created by Adrien Coquet
from the Noun Project

Closing Reflections

Please discuss the following questions with your partner or in your small group:

- What are some differences between a rectangular prism and a triangular prism?
- How are net diagrams useful in understanding the surface area of a three-dimensional figure?

Problem Solving with Volume

Arranging Boxes in a Container



Learning Goals

After this lesson, you should understand

- the volume of a three-dimensional object is a measurement of the space inside the object.
- the volume of a rectangular prism is the product of the length, width, and depth.
- the volume of an object is measured in cubic units.

After this lesson, you should be able to

- calculate the volume of a rectangular prism.
- solve real-world problems involving volume.



Created by Adrien Cognet
from the Noun Project



Created by Jintana Jejjara
from the Noun Project

Fitting Boxes in a Container

Ava and Max run a clothing donation center. When they have extra clothes, they send them to other towns. They pack the clothes into shoe boxes. Then they pack the shoe boxes in a shipping container. The shipping container is 5 feet wide, 2 feet long, and 3 feet tall. The shoe boxes are 10 inches wide, 12 inches long, and 8 inches tall.

(Q1) What is the volume of the shipping container?

(Q2) What is the volume of a shoe box? Find the volume in cubic inches and in cubic feet. Round to the nearest hundredth of a cubic foot. **Note:** 12 inches = 1 foot.

There are several ways to arrange the shoe boxes in the container. Ava and Max want the shoe boxes to be stacked neatly in the container. The first shoe box must be placed tightly in a bottom corner so that three of its sides touch the container. Then, more shoe boxes are stacked next to it and on top of it. Ava and Max want to arrange the shoe boxes to fit the most boxes in the container.

The figure below shows one way to place the first shoe box in the container.

Packing Approach 1

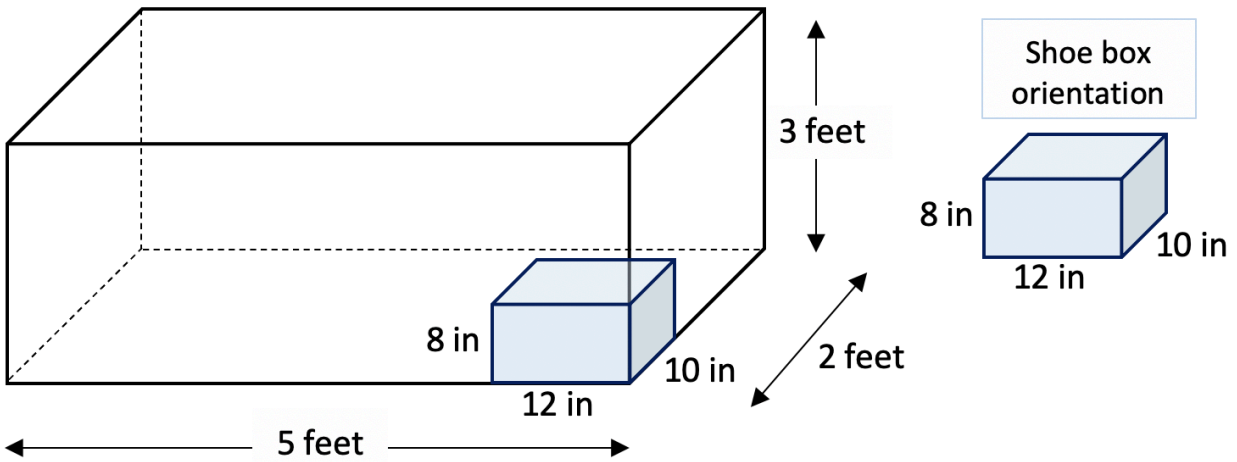

(Q3) Ava uses Packing Approach 1. Work with your partner or in your small group to answer the following questions:

(a) How many shoe boxes can she fit on the bottom row? **Note:** Shoe boxes in the bottom row touch the bottom of the container.

(b) How many shoe boxes can be stacked vertically?

(c) Overall, how many shoe boxes can fit inside the container?

(d) What amount of space will be taken up by all the shoe boxes?

(e) What percentage of the space inside the shipping container will be used by all of the shoe boxes? Round to the nearest percent.

There are several other ways that the shoe boxes can be arranged. Let's examine a different approach.

Packing Approach 2

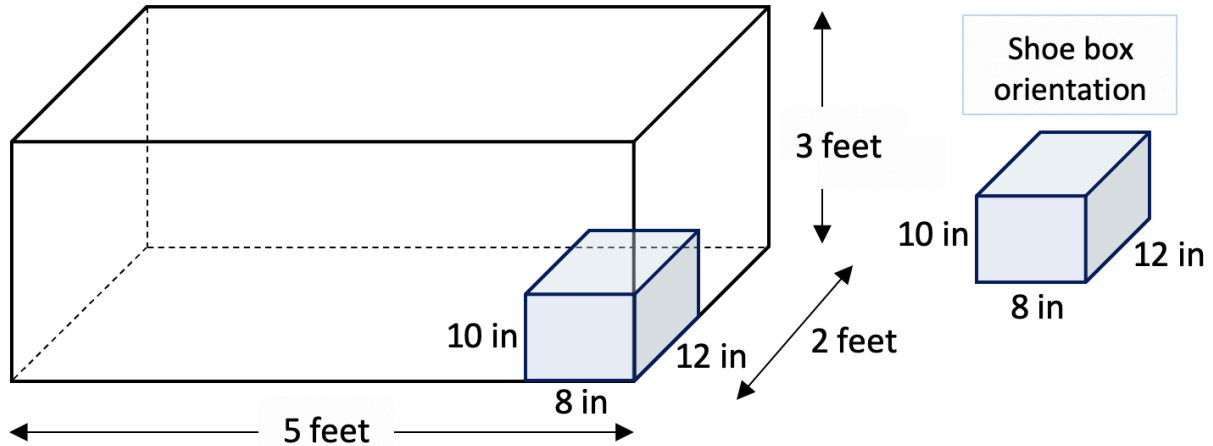

(Q4) If Max uses Packing Approach 2, answer the following questions:

(a) How many shoe boxes can he fit on the bottom row? Shoe boxes in the bottom row touch the bottom of the container.

(b) How many shoe boxes can be stacked vertically?

(c) Overall, how many shoe boxes can fit inside the container?

(d) What amount of space will be taken up by all the shoe boxes?

(e) What percentage of the space inside the shipping container will be used by all of the shoe boxes?

(Q5) How many different ways can the shoe boxes be arranged in the container? Discuss with your partner or in your small group. Record your thinking below.

(Q6) Working with your partner or in your small group, can you find a packing approach that better utilizes the space inside the shipping container? Can 100% of the shipping container space be used? Record your thinking in the given space. Use quantitative information in your answer. For example, the number of shoe boxes that fit into the container, the percentage of the space is utilized.



Created by Adrien Coquet
from the Noun Project



Created by bintang kejora
from the Noun Project

Volume of Water in a Pool

- (Q7)** A rectangular pool has a length of 15 feet, a width of 10 feet, and a depth of 4 feet. John filled the entire pool with water, but then drained the pool so that half of the water remained. What is the volume of the remaining water in the pool?



Created by Claire Jones
from the Noun Project



Created by bintang kejora
from the Noun Project



Created by Adrien Coquet
from the Noun Project

Closing Reflections

Please discuss the following questions with your partner or in your small group:

- What is the difference between a cubic foot and a cubic inch?
- Why is volume measured in cubic units?