

Ante la suspensión de clases presenciales y a fin de garantizar la continuidad pedagógica de los estudiantes se lleva a cabo las siguientes acciones:

Se procederá a trabajar los temas planeados para el corriente mes mediante trabajos prácticos que constaran de 4 clases.

Los mismos deberán ser entregados el martes 7 de abril.

### Class 1

1. **Read and paint.** (lea y pinte)

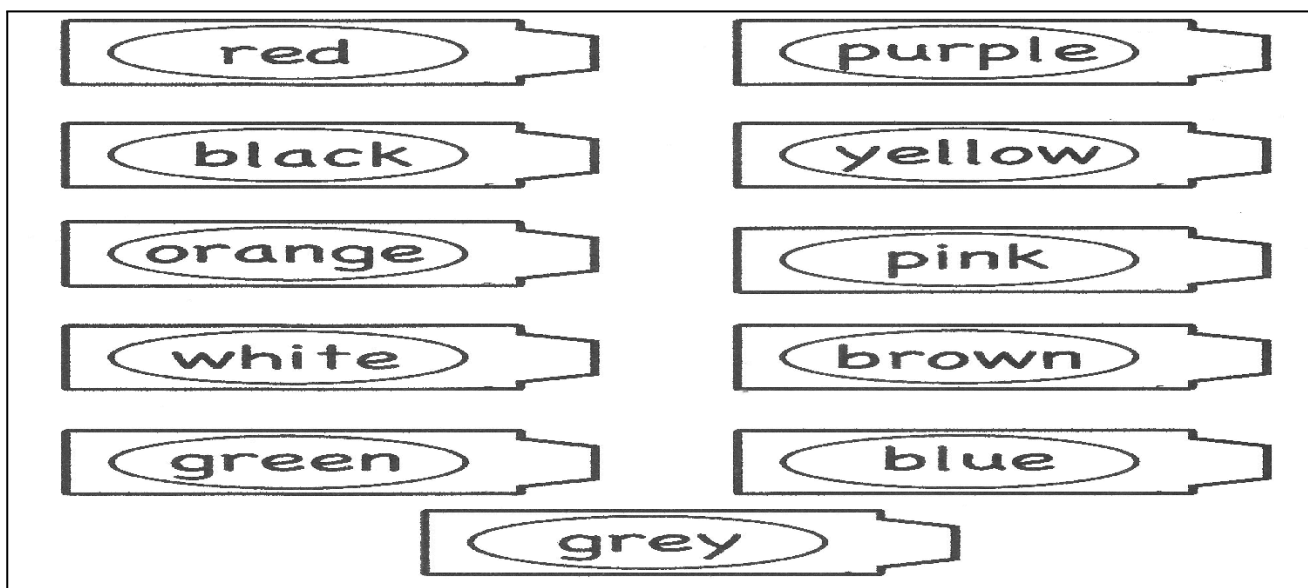

2. **What 's the weather like?** (¿Cómo está el clima?)

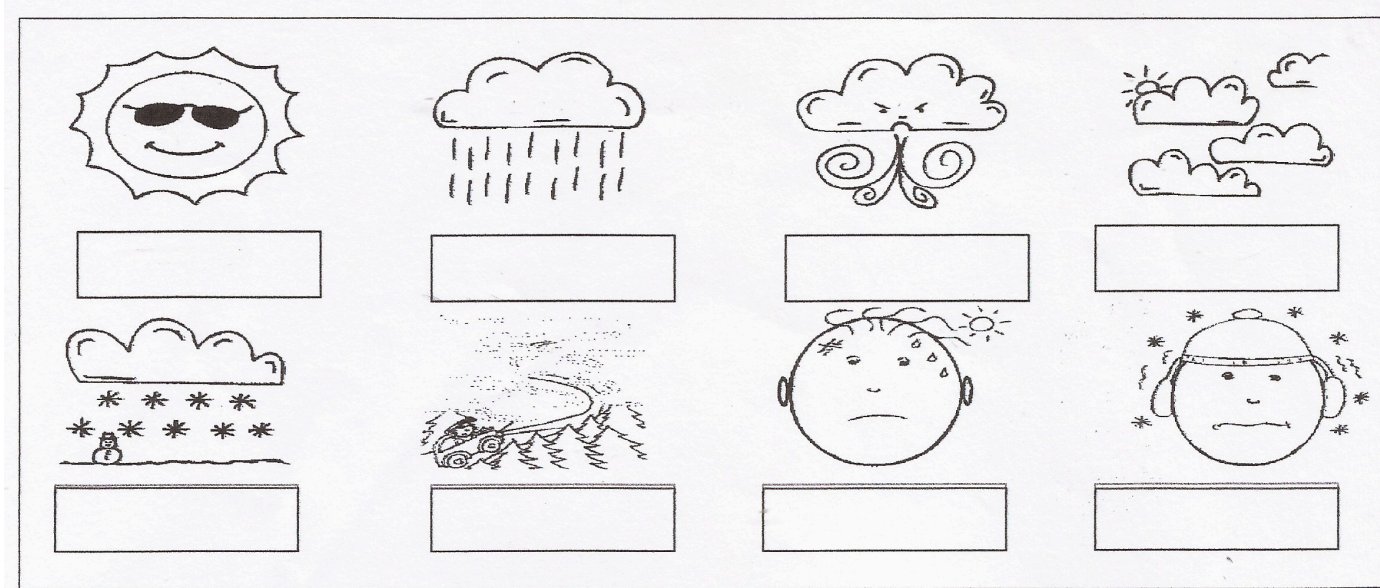

**FOGGY – COLD – SNOWY – HOT – CLOUDY – SUNNY – WINDY – RAINY**

3. **Read and draw colourful stripes on the snakes.** (Lea y dibuje rayas de color en las serpientes)

**Strikes= rayas**

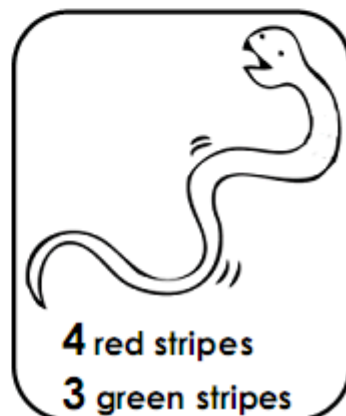
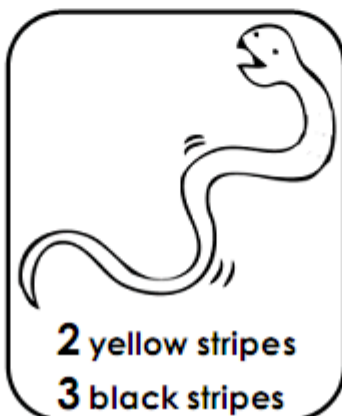
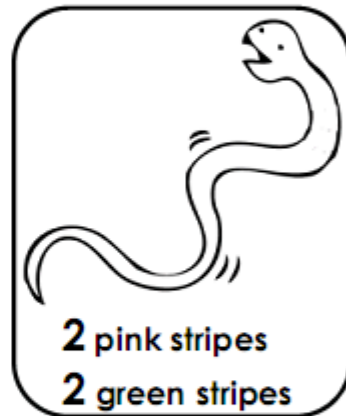
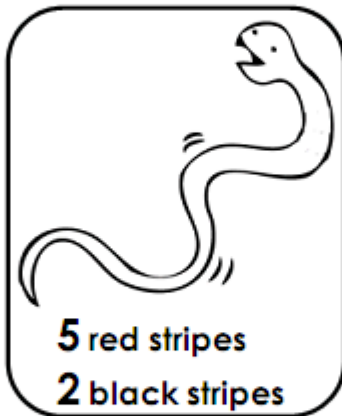
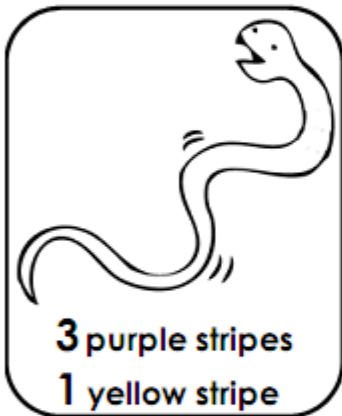
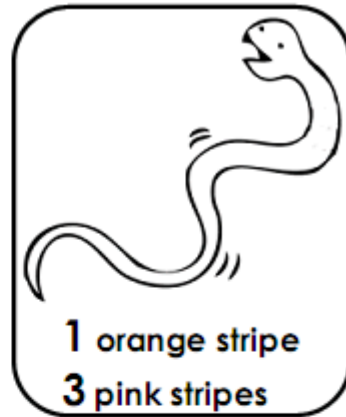
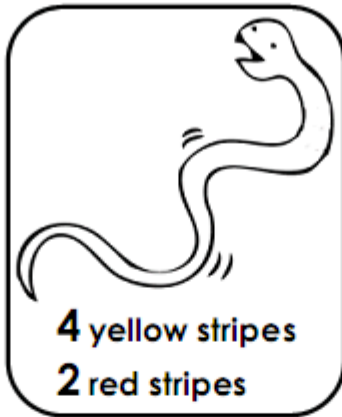
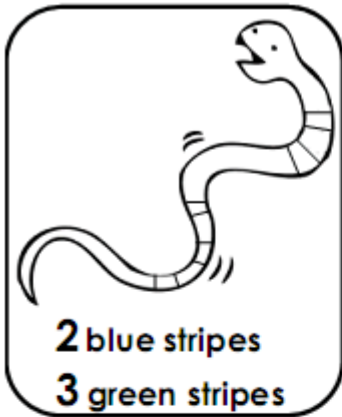

**Class 2**

**1. Join and write (Unir y escribir)**

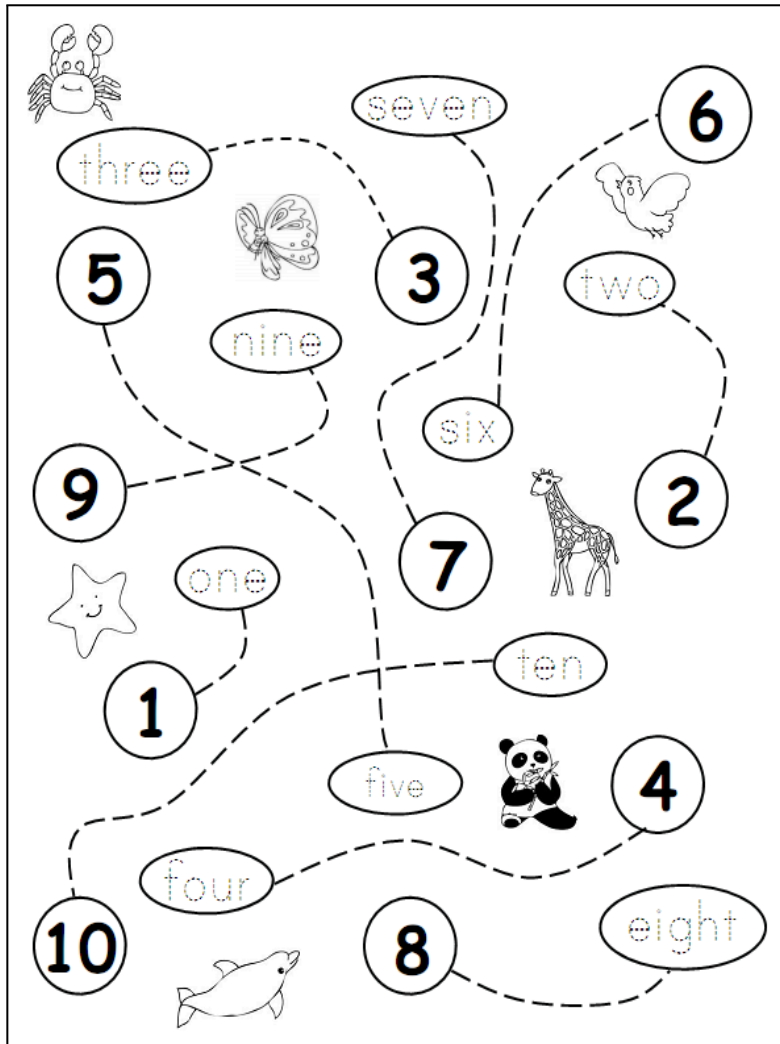

**2. Write the missing letters. (escriba las letras que faltan)**

1. \_ N \_
2. TW \_
3. THR \_ \_
4. F \_ \_ R
5. F \_ V \_
6. S \_ X
7. S \_ V \_ N
8. \_ \_ GHT
9. N \_ N \_
10. T \_ N

3. Count and write. (Cuenta y escriba)

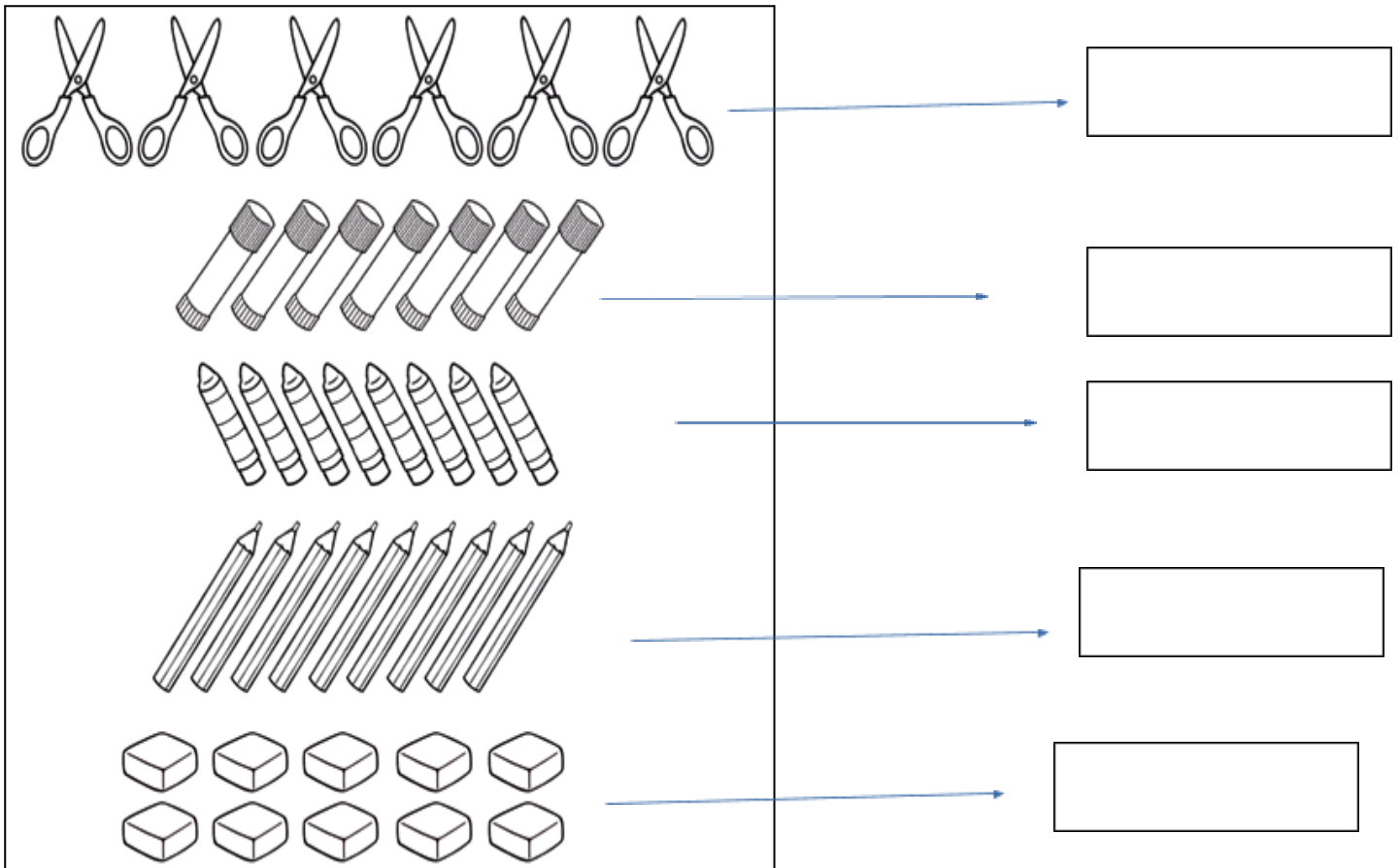

6

7

8

9

10

4. Read and colour. (¡Lea y coloree)

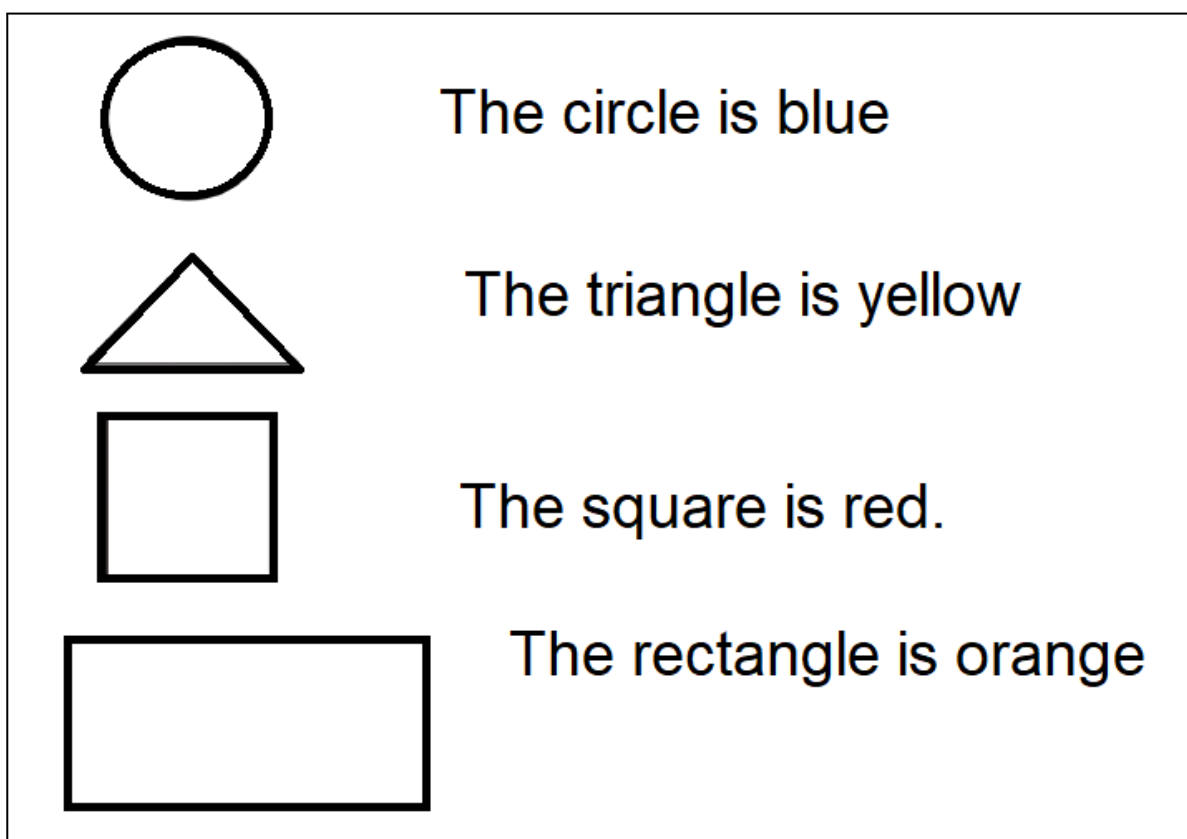

The circle is blue

The triangle is yellow

The square is red.

The rectangle is orange

Class 3

1. Write the object of the classroom. (Escriba los nombres de los objetos escolares)

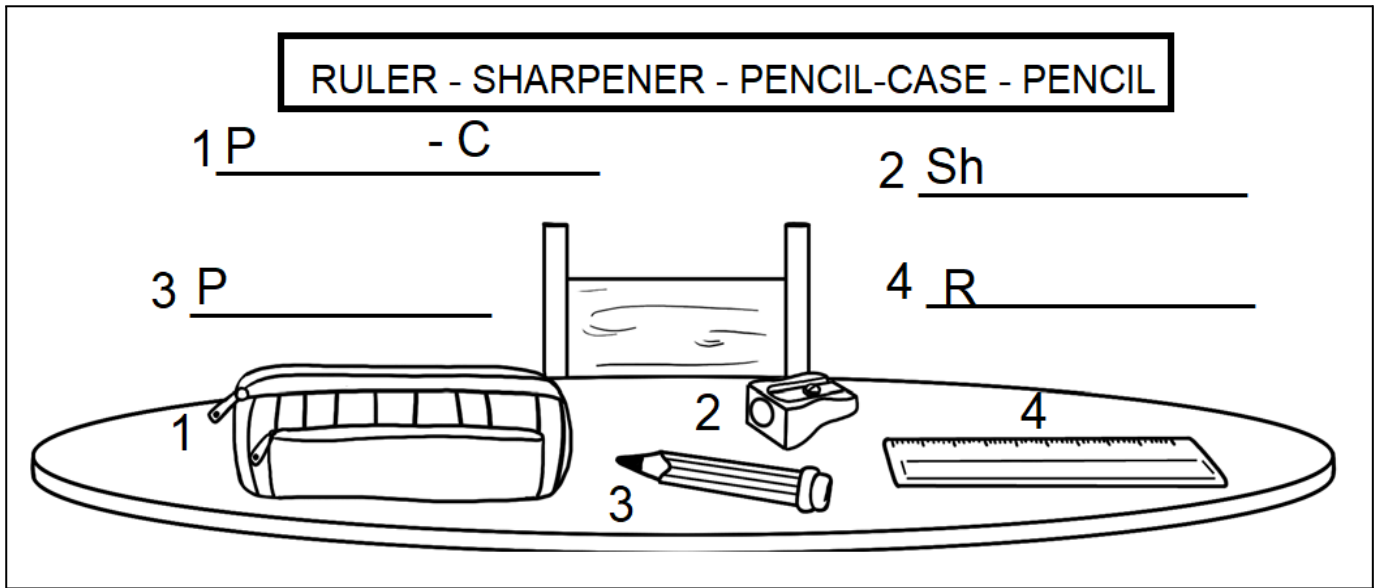

2. Read and circle the correct sentences. (Lea y encierre con círculo la opción correcta)

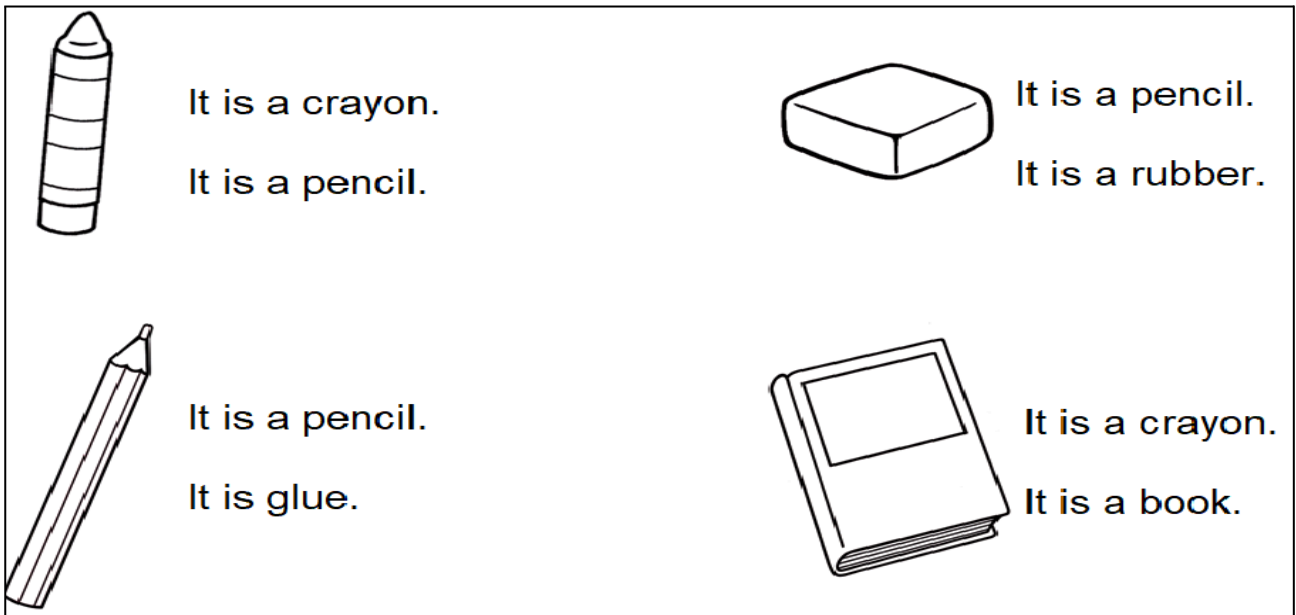

3. Answer about your school objects. (Conteste sobre sus objetos escolares)







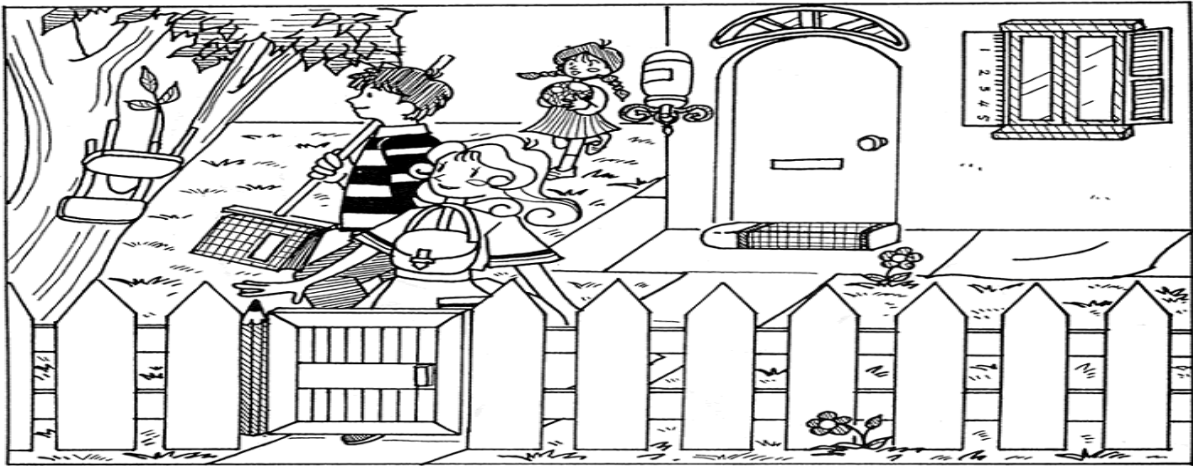

**What colour is your glue? It is white.**

- What colour is your pencil-case? \_\_\_\_\_
- What colour is your book? \_\_\_\_\_
- What colour is your rubber? \_\_\_\_\_
- What colour is your ruler? \_\_\_\_\_
- What colour is your crayon? \_\_\_\_\_

**Class 4**

**1. Find the hidden school objects. (Encuentre los objetos escolares escondidos)**



	pencil		ruler
	book		bag
	glue		rubber
	chair		paper

**2. Look, paint, draw and write. (Mire, pinte, dibuje y escriba) HAVE GOT= TENER**

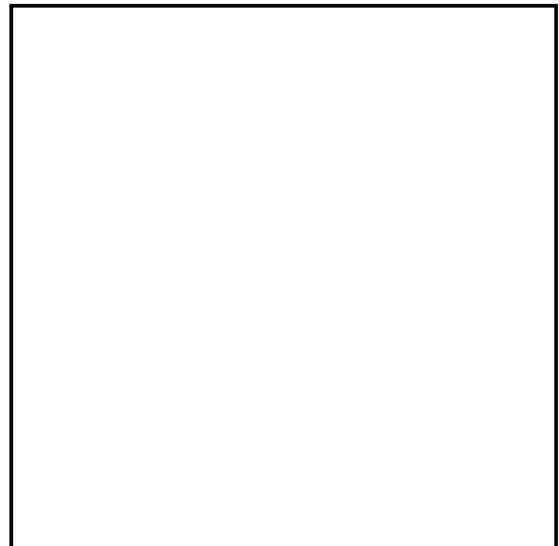
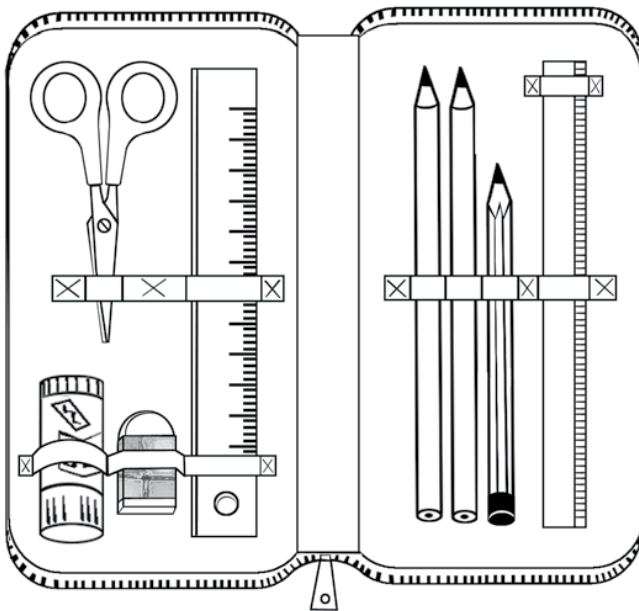

In my pencil-case I have got three green pencils, a white rubber, two pink rulers, a blue glue stick and purple scissors.

In my \_\_\_\_\_ I have got  
 \_\_\_\_\_  
 \_\_\_\_\_  
 \_\_\_\_\_