

## Dynamics AP Exam Style Problems

### Scenario 1: Helicopter carrying Package:

A helicopter holding a 70-kilogram package suspended from a rope 5.0 meters long accelerates upward at a rate of  $5.2 \text{ m/s}^2$ . Neglect air resistance on the package.

a. On the diagram below, draw and label all of the forces acting on the package. [3]

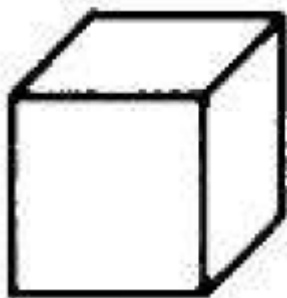

b. Determine the tension in the rope. [2]

*Scenario 2: 3 Block / Ramp System*

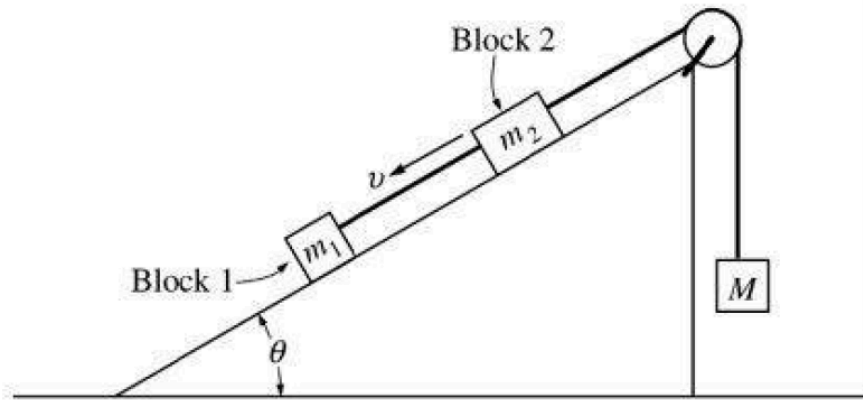

Blocks 1 and 2 of masses  $m_1$  and  $m_2$ , respectively, are connected by a light string, as shown above. These blocks are further connected to a block of mass  $M$  by another light string that passes over a pulley of negligible mass and friction. Blocks 1 and 2 move with a constant velocity  $v$  down the inclined plane, which makes an angle  $\theta$  with the horizontal. The kinetic frictional force on block 1 is  $f$  and that on block 2 is  $2f$ .

a. On the figure below, draw and label all the forces on block  $m_1$ . [3]

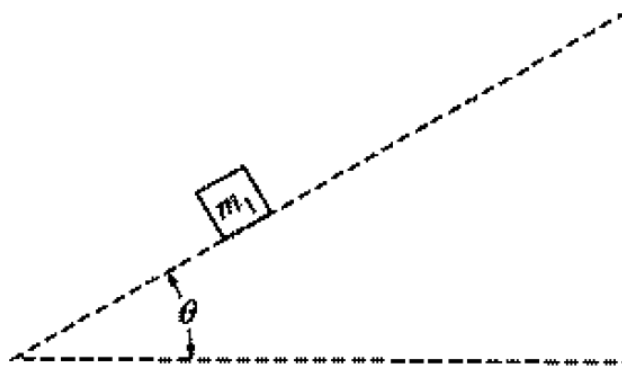

Express your answers to each of the following in terms of  $m_1$ ,  $m_2$ ,  $g$ ,  $\theta$ , and  $f$ .

- b. Determine the coefficient of kinetic friction between the inclined plane and block 1. [1]
- c. Determine the value of the suspended mass  $M$  that allows blocks 1 and 2 to move with constant velocity down the plane. [2]
- d. The string between blocks 1 and 2 is now cut. Determine the acceleration of block 1 while it is on the inclined plane. [

*Scenario 3: 3 Block / Pulley System*

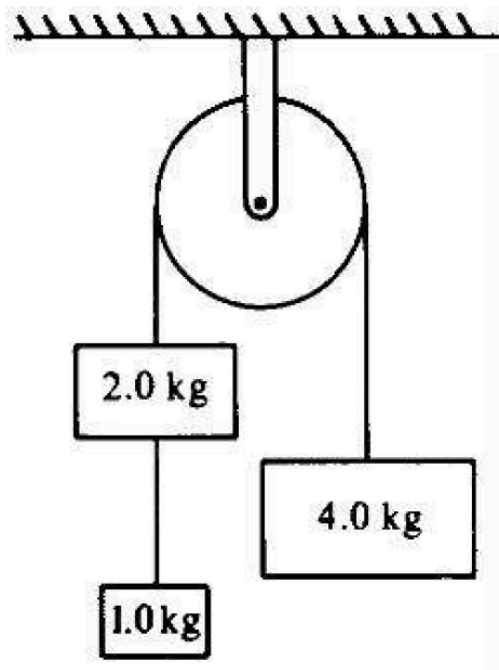

Three blocks of masses 1.0, 2.0, and 4.0 kilograms are connected by massless strings, one of which passes over a frictionless pulley of negligible mass, as shown above. The blocks are released and allowed to accelerate. Calculate each of the following.

- The acceleration of the 4-kilogram block
- The tension in the string supporting the 4-kilogram block
- The tension in the string connected to the 1-kilogram block

*Scenario 4: Two Students Rope Climbing*

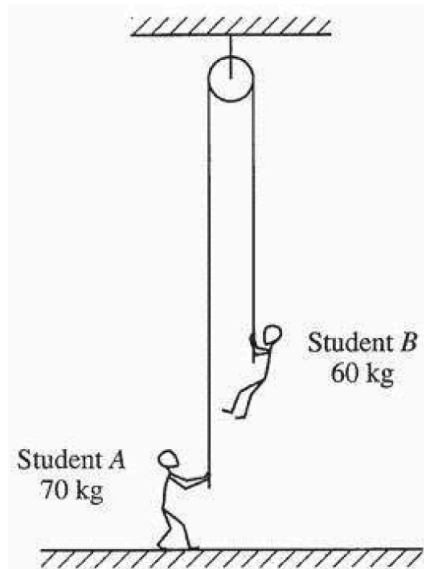

A rope of negligible mass passes over a pulley of negligible mass attached to the ceiling, as shown above. One end of the rope is held by Student A of mass 70 kg, who is at rest on the floor. The opposite end of the rope is held by Student B of mass 60 kg, who is suspended at rest above the floor. Use  $g = 10 \text{ m/s}^2$ .

a. On the dots below that represent the students, draw and label free-body diagrams showing the forces on Student A and on Student B.

● Student B

Student A ●

b. Calculate the magnitude of the force exerted by the floor on Student A.

Student B now climbs up the rope at a constant acceleration of  $0.25 \text{ m/s}^2$  with respect to the floor.

c. Calculate the tension in the rope while Student B is accelerating.

d. As Student B is accelerating, is Student A pulled upward off the floor? Justify your answer.

e. With what minimum acceleration must Student B climb up the rope to lift Student A upward off the floor?

### Scenario 5: Sled on Muddy Slope

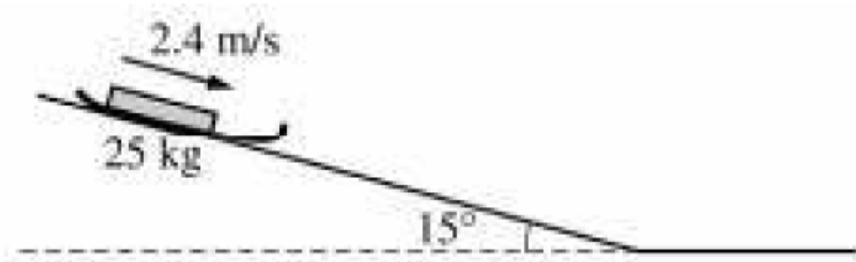

An empty sled of mass 25 kg slides down a muddy hill with a constant speed of 2.4 m/s. The slope of the hill is inclined at an angle of  $15^\circ$  with the horizontal as shown in the figure above.

- Calculate the time it takes the sled to go 21 m down the slope.
- On the dot below that represents the sled, draw/label a free-body diagram for the sled as it slides down the slope



- Calculate the frictional force on the sled as it slides down the slope.
- Calculate the coefficient of friction between the sled and the muddy surface of the slope.
- The sled reaches the bottom of the slope and continues on the horizontal ground. Assume the same coefficient of friction.
  - In terms of velocity and acceleration, describe the motion of the sled as it travels on the horizontal ground.
  - On the axes below, sketch a graph of speed  $v$  versus time  $t$  for the sled. Include both the sled's travel down the slope and across the horizontal ground. Clearly indicate with the symbol  $t_f$  the time at which the sled leaves the slope.



*Scenario 6: Forklift moving a Box*



A 300-kg box rests on a platform attached to a forklift, shown above. Starting from rest at time  $t = 0$ , the box is lowered with a downward acceleration of  $1.5 \text{ m/s}^2$

a. Determine the upward force exerted by the horizontal platform on the box as it is lowered.

At time  $t = 0$ , the forklift also begins to move forward with an acceleration of  $2 \text{ m/s}^2$  while lowering the box as described above. The box does not slip or tip over.

b. Determine the frictional force on the box.

c. Given that the box does not slip, determine the minimum possible coefficient of friction between the box and the platform.

d. Determine an equation for the path of the box that expresses  $y$  as a function of  $x$  (and not of  $t$ ), assuming that, at time  $t = 0$ , the box has a horizontal position  $x = 0$  and a vertical position  $y = 2 \text{ m}$  above the ground, with zero velocity.

e. On the axes below sketch the path taken by the box

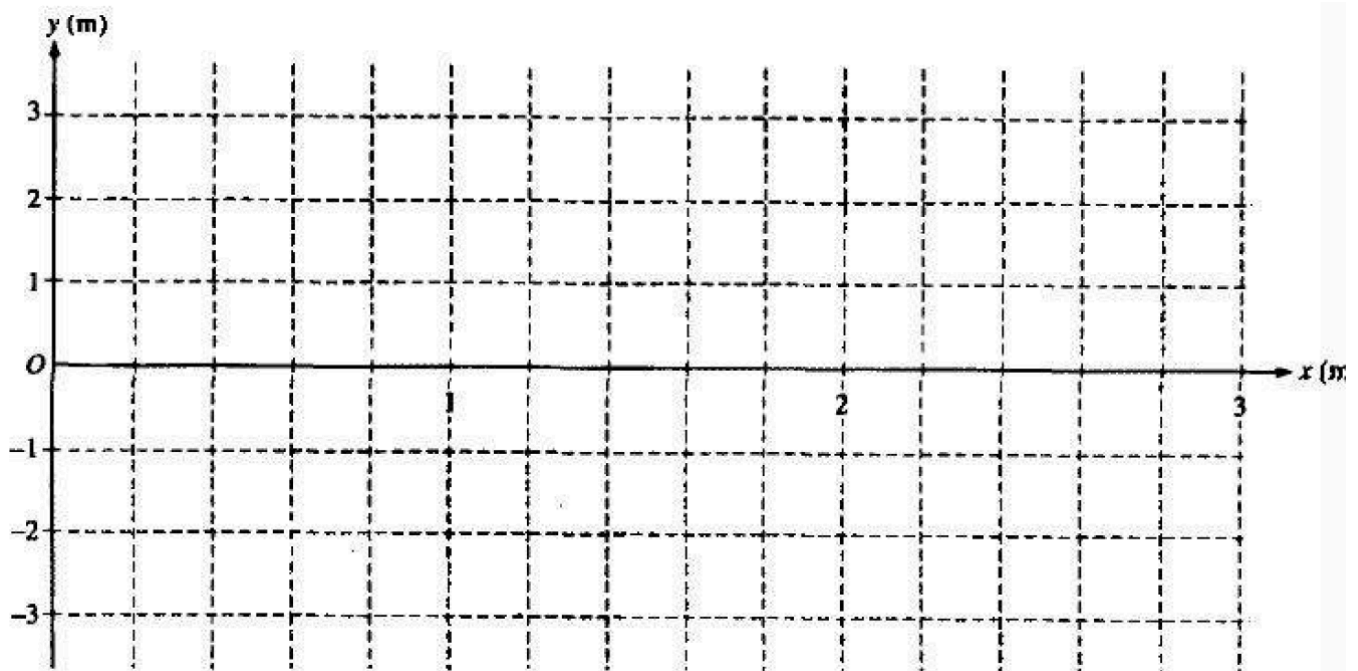

### Scenario 7: Thrown Ball

A ball of mass  $M$  is thrown vertically upward with an initial speed of  $v_0$ . It experiences a force of air resistance given by  $F = -kv$ , where  $k$  is a positive constant. The positive direction for all vector quantities is upward. Express all algebraic answers in terms of  $M$ ,  $k$ ,  $v_0$ , and fundamental constants.

a. Does the magnitude of the acceleration of the ball increase, decrease, or remain the same as the ball moves upward?

\_\_\_\_\_ increases                      \_\_\_\_\_ decreases                      \_\_\_\_\_ remains the same  
Justify your answer.

b. Determine the terminal speed of the ball as it moves downward.

c. Does it take longer for the ball to rise to its maximum height or to fall from its maximum height back to the height from which it was thrown?

\_\_\_\_\_ longer to rise                      \_\_\_\_\_ longer to fall  
Justify your answer.

d. On the axes below, sketch a graph of velocity versus time for the upward and downward parts of the ball's flight, where  $t_f$  is the time at which the ball returns to the height from which it was thrown.

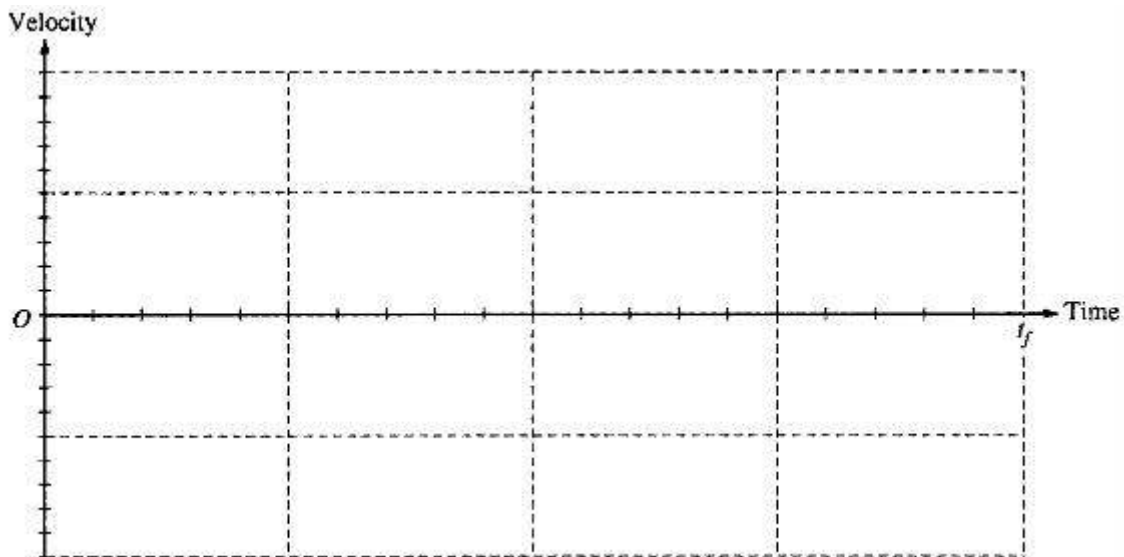

*Scenario 8: Static Monkey*

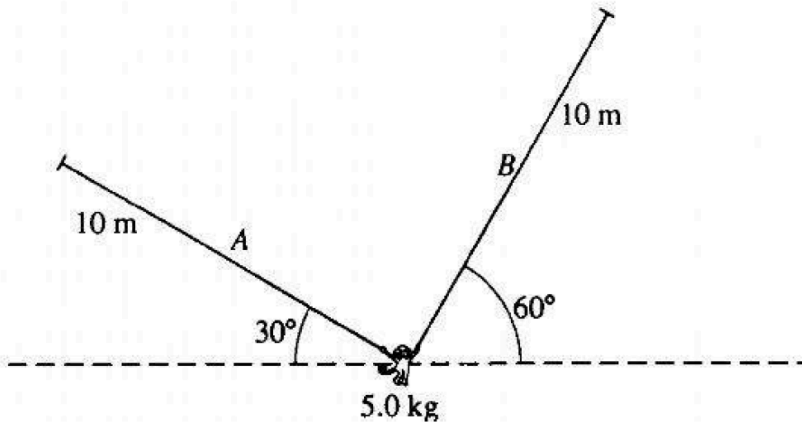

$$\begin{aligned}\sin 30^\circ &= 0.50 \\ \cos 30^\circ &= 0.87 \\ \tan 30^\circ &= 0.58\end{aligned}$$

$$\begin{aligned}\sin 60^\circ &= 0.87 \\ \cos 60^\circ &= 0.50 \\ \tan 60^\circ &= 1.73\end{aligned}$$

A 5.0-kilogram monkey hangs initially at rest from two vines, A and B, as shown above. Each of the vines has length 10 meters and negligible mass.

a. On the figure below, draw and label all of the forces acting on the monkey. (Do not resolve the forces into components, but do indicate their directions.)



b. Determine the tension in vine B while the monkey is at rest.