

69/70 Instrument Gauge Cluster6.docx. This document was originally written for a car with no tachometer, since I don't have a Tach car at my disposal. However thanks to some pictures from mqu02, it has been updated to include the tach version, and starts on page 18.

If you simply want to test the operation of the gauges, Desert Classic Parts sells tester "GT-Ford-1" for about \$30 that will allow you to check the gauges at low, medium, high, and test the IVR for a pulse. All of this is done before removing the instrument panel.

Removing the gauge cluster/instrument panel

First, disconnect the battery. To get the gauge cluster out you will need to remove 5 screws around the edges, then the dash pad, and to do that you need to remove the trim on each side below the pad (by the doors) and the trim in the middle around the radio. Don't forget to unplug the clock harness before removing the dash pad, as the clock is attached. The cluster will have a screw at each side at the bottom and two on top. Move it out far enough to get to the speedometer cable- push it in slightly, release the detent and pull it off. If it isn't 50+ years old, the plastic may survive the ordeal, otherwise you may need a new cable. You can also loosen the cable from the tranny to give you more slack up top. The last impediment is the plug: it also has a detent at the top and bottom that should be pushed in and the plug will release. There are on-line videos for removing the dash pad. It should take less than an hour.

Identification:

This is for Testing Non- Tach cars with an Ammeter, see page 18 for Tach cars

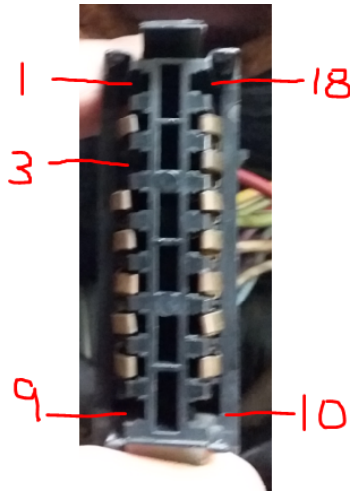

This is the plug as it sits in the car. It has blank spots at 1, 3, 9, 10, and 18.

The blank at 3 allows you to figure out the orientation. This picture is for a non-tach version. I will include an illustration for the tach version further on.

This has the gauge cluster (non-tach version) on the work bench with a look at the flex circuit. It's the mirror image of the plug and since there aren't any circuits at the top and bottom, it's easy to see where the blank at 3 resides. The two connections each for the fuel and temperature gauges are on the right.



Testing can be done using the plug **in the car** and on the gauge cluster **on the bench** to determine how everything works.

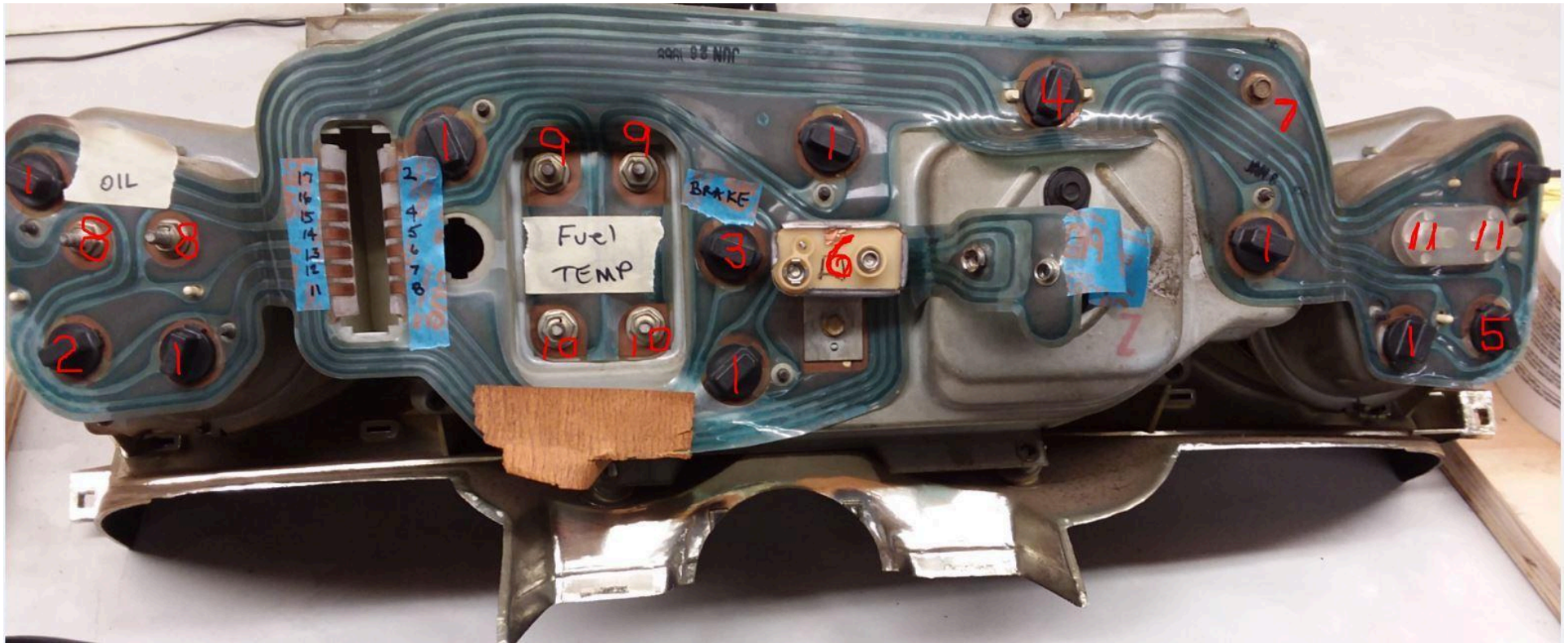

This is for the non-tach version, see tach version on page 18.

1's are the backlights- there are eight of them.

2 right hand turn indicator light

3 brake warning light

4 high beam indicator light

5 left hand turn indicator light

6 Gauge Constant Voltage Regulator. Also known as IVR instrument voltage regulator. The flex circuit's connection to the regulator has been unsnapped and is being held back with blue painters tape. You can see the attachment screw below the 6. This screw holds the regulator in place **and** gives it an electrical connection to chassis ground- without which it would not operate.

7 is one of the chassis grounds that allows the regulator to operate. It grounds the center metal housing. The right and left gauge clusters are not grounded.

8 oil gauge terminals

9 fuel gauge terminals

10 temperature gauge terminals

11 ammeter terminals- they are protected with an insulator because they are always hot and NOT fused. If something shorts to these it will melt the connecting traces on the flex circuit like a fuse. This insulator cap is available from NPD.

OHMMETERS

Now that everything is identified, let's get on to testing. You will need a Volt/Ohm meter, or VOM. There are many makers and models. Some of the cheaper or older models are analog- that is they have a needle, but most likely you will have a digital unit. Usually one lead goes into the – or common plug, and the other goes into a socket that is marked with an ohm symbol Ω . Set it to the lowest ohm setting (something like 200), or even one that has a buzzer to let you know there is continuity. Turn it on without the leads touching and see what it displays for an "open circuit", **no conductivity, or no continuity**, also known as infinity, because there is an infinite numbers of ohms of resistance. Now see what you get by touching the leads together, known as "shorted", or a short circuit. It should read zero or very close. You must be certain to know the difference between infinity (an open circuit) and zero ohms (a short circuit). Two of my meters show "1" for infinity, another shows "O.L" (overload) and still another "OL.". With digital meters the reading may bounce around, even if the probes are clamped onto one another. Make sure to get a good connection between the probe and the flex circuit. You can clean the copper on the flex with Brasso, a Q-tip and toothbrush. If in doubt as to how to use an ohmmeter, watch an on-line video, or read the manual (I know that would be against our general principals).

GAUGE POSTS SHORTING TO METAL HOUSING

This is a VERY frequent problem. The gauge posts must not come in contact with the metal housings. Any time the gauges have been moved or the flex circuit reattached, or in any way taken apart, you definitely need to check for a short circuit. If even one of the gauge posts touches the metal housing, it will create a short, the voltage will drop, nothing will work, and the gauge voltage regulator could be damaged. It is fortunate that the 69/70s have a 10 ohm resistor wire in front of the regulator, so it may survive the short. Clamp one ohmmeter lead to the center metal housing, and clamp the other, in turn, to each temp and fuel gauge post. **You must have infinite ohms (no conductivity)**, if not you need to reposition the gauge(s) so they don't touch the edge of the holes. Do the same for the oil gauge, connecting one lead to the left housing and the other to each gauge post in turn.



The back side of the fuel and temp for my non-tach car. The gauge posts go through the metal housings (not shown here), and must be centered in the holes, then the insulators (1) are positioned, then the flex circuit is attached, and washers and nuts (2) are tightened.

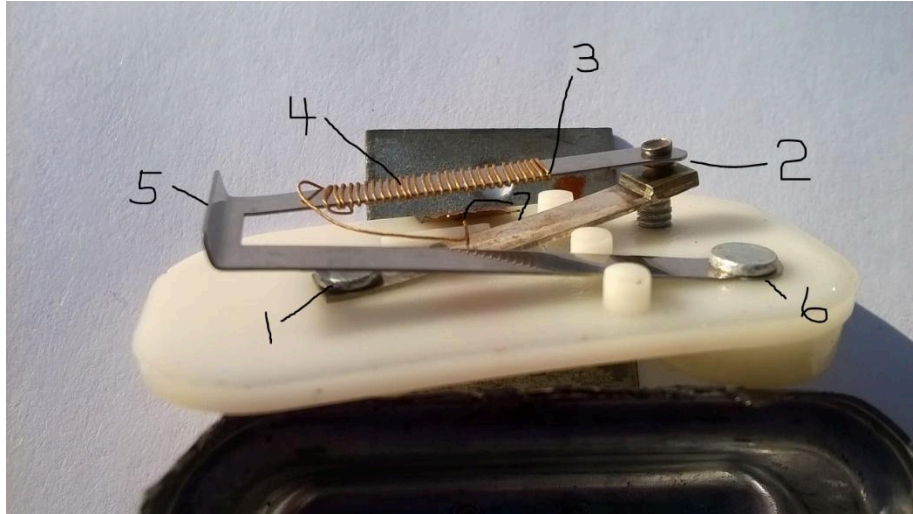

IVR OR GAUGE VOLTAGE REGULATOR

Since the Gauge Voltage Regulator, also known as the IVR (Instrument Voltage Regulator) is part of the gauge system, this would be a good place for a description of it. The stock OEM regulator uses a bi-metal with a heater. A bi-metal is a strip of metal that is two layers of dissimilar metals bonded together like a sandwich. When it gets hot it bends, because one metal expands more than the other, warping it.

The contacts are **normally closed** and open when hot. Then it cools and constantly repeats. The contacts are on the right rear in the picture at (2). The IVR is also in series with a 10 ohm resistor wire.

The IVR will output a voltage that is dependent on four variables. The first one is the applied voltage, which can range from battery voltage of approx. 12v up to approx. 15v if the alternator is charging. And the last three variables are the three gauge sensors that can each be anywhere from 10 to 73 ohms, depending on what they are measuring at the time. The IVRs output voltage and pulse rate will vary depending on those four conditions.

The gauges don't care about the pulsing because by design they react very slowly, and it doesn't affect them. When the car is started the IVR doesn't pulse immediately, it outputs roughly from 8v to 5v for up to 44 seconds until it warms up.

slowly, and it doesn't affect them.

When the car is started the IVR doesn't pulse immediately, it outputs roughly from 8v to 5v for up to 44 seconds until it warms up. Power from the ignition switch connects to the left rear terminal (1) in the picture. That goes up to the cycling contact on the right rear (2), and flows down and around the corner through the bi-metal (5) to the right front terminal (6). The heater wire (4) is welded to the bottom side of the bi-metal on the right (3) near the switching contact. The heater is around 61 ohms. It wraps around the bi-metal and goes out the rear (7) where it connects to the metal case, which is grounded to the chassis when attached. So, as the bi-metal heats it bends and lifts, opening the contact and removing power from the heater. It cools and closes, and constantly repeats.

OEM MUSTANG IVR TEST

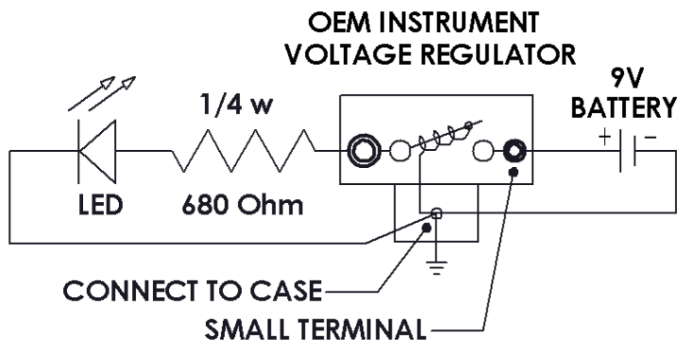

Note, this is just a quick and dirty way to test the regulator.

The Ford manual says it should have "a pulsing voltage with an effective average value of 5.0 volts". This note may be a holdover from previous years, because the 69 was the first year they put a 10 ohm resistor wire in front of the regulator, which changes the way the IVR works. In fact, the output varies with the combined parallel resistances of the three gauge sensors. It outputs different voltages and pulse times, and under some conditions it may not pulse at all.

At any rate, there was never an attempt made for technicians to actually measure the output, because in the 60s there were no hand-held instruments that could measure a pulsing DC output. The manufacturer probably used an oscilloscope.

Just look for the LED to pulse. You could also measure the output with a digital voltmeter, but the numbers jump all over and its hard to know what it is doing.

IVR Comparison

This is a comparison of a stock OEM IVR (which is electro-mechanical) to an Aftermarket IVR (which is electronic). When initially turned on, the OEM IVR takes time to warmup, then it starts to pulse. During this warmup time, you have the full output voltage until the first pulse. After the first pulse, the subsequent pulses come at a much faster rate. This gives the meters a little **kick**, and allows them to come up to their operating range a little faster than an Aftermarket IVR, which always tries to maintain 5v. For instance, on Low the gauges get 8.35v for 6 seconds before the IVR pulses. In all conditions, the gauges respond faster to the OEM IVR.

Also, in the rare instance where all 3 sensors are on High at the same time, it appears to load-down the Aftermarket IVR (see the voltage is 4.96) and this lower voltage results in the gauge needles not rising as high as the OEM IVR. They register lower by “two widths” of the needle. OEM IVRs are still available- I just bought a used and operating one for \$15 plus \$9 shipping. The Aftermarket IVR, while not ideal, is still acceptable.

		voltage across IVR and Gauges	time to 1st pulse	Needle time to half of operatin g point	Needle time to operatin g point
OEM IVR	low	8.35	6	5	11
	1/2	6.43	17	7	16
	high	5.23	44	11	45
Aftermarket IVR	low	5.03	none	10	30
	1/2	5.02	none	14	65
	high	4.96	none	12	60

GAUGES

Ford intentionally developed gauges that take time to react- they call this dampening. This is so the gauge doesn't bounce all over when you take a curve or do a jump like the General Lee. **All the gauges are reportedly the same except for the scale.** Even though the oil sender measures pressure and the water sender measures temperature, and the fuel measures fluid level, all three sensors are just variable resistors that read from 73 ohms on Low to 10 ohms on Hi. Ford developed a gauge that doesn't use the typical D'Arsonval meter movement. It is a bi-metal device with a heater to make it move. That's why they have so much dampening- it is inherent in the design, and probably costs much less than a typical meter movement. A little more explanation is probably in order here: a bi-metal is two sheets of dissimilar metal formed together in layers like a sandwich. They use materials that have greatly different expansion rates. When heat is applied they bend, because one side expands more than the other. The bending is very predictable and repeatable.

If you just want to see if the gauge operates, connect two 1.5v D cell flashlight batteries in series across the gauge terminals. This will apply 3v to the gauge, and in my experience it will deflect the pointer to "about a pointers width *above* high". It doesn't matter which way you hook-up the battery.

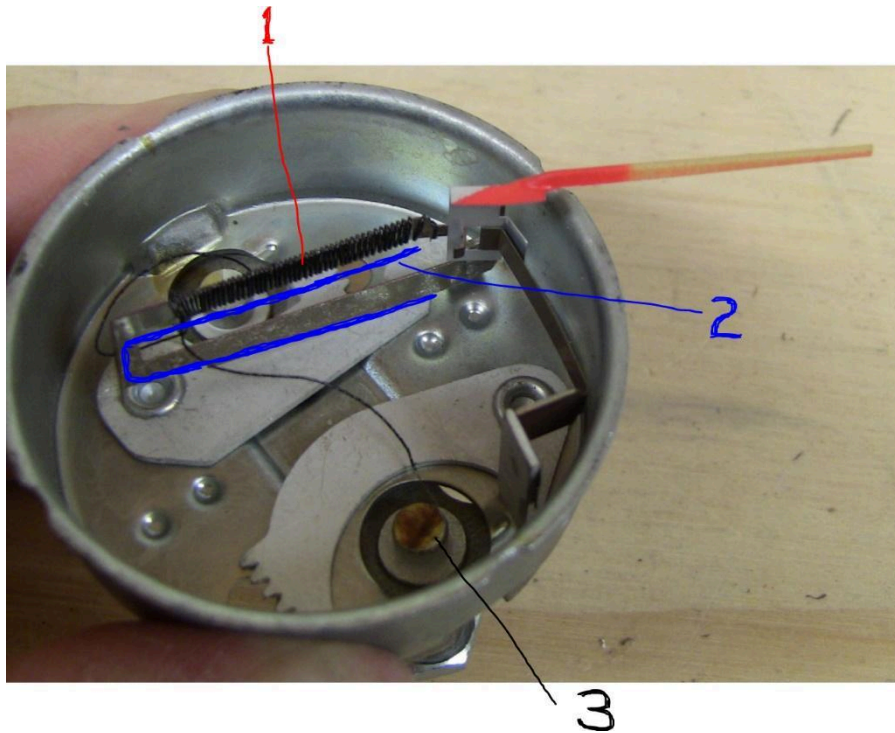

This is a gauge with the front scale removed. The heater (1) is wrapped around the bi-metal (2) and connects to the gauge posts, one of which is shown at (3). The pointer is attached to the bi-metal on its left side and a spring on the right. You can see the two adjustment holes in the back with the "saw-tooth" adjustments in the arms. The heater is the only thing electrical about the gauge, and has a resistance in the range of 12.2 to 12.8 ohms. The 68 and older cars measure 16-18 ohms.

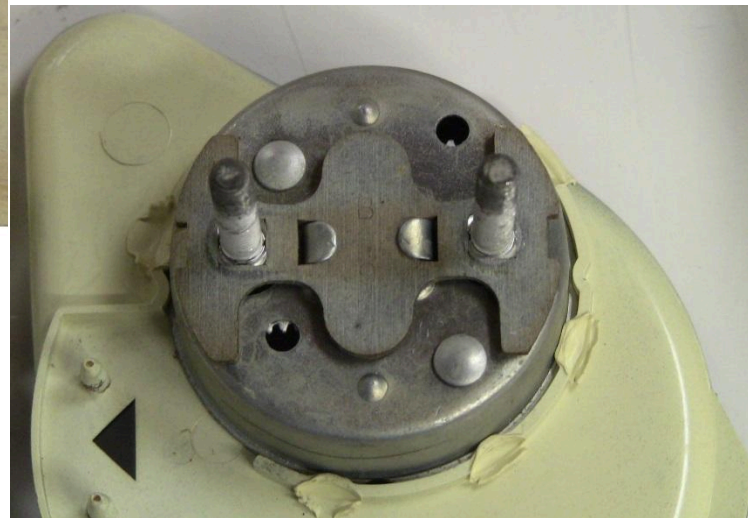

This is a back side the gauge. You can see the two adjustment holes with "teeth" and the gauge electrical posts.

To Calibrate a Gauge: you will need a 78 ohm 1/2w resistor for low, a 10 ohm 1 w resistor for high and a 5VDC power supply to set the gauge back to factory specs. Most of us don't have a 5vdc power supply, so if you feel you must calibrate your gauges, a good substitute is an aftermarket IVR. They are all electronic, readily available from all the major parts houses, and while they may not be ideal to use in the car (see IVR for previously mentioned reasons), they are perfect for calibrating the gauges. On a 69/70, don't forget the addition of a 10 ohm 5w resistor between the battery and regulator. If you're like me, you can expect to spend a lot of time doing this. That's why you need the big car battery and have it fully charged, as it takes power to run these gauges.

Use a small screwdriver in through the holes in the back of the gauge to engage the teeth and move the arms. You will see the pointer move. Both adjustments affect the other and once you change one you need to check the other since it will change some too. Make small adjustments. The ZERO adjustment affects the position of LOW (but so does Span), and the SPAN adjustment changes the sensitivity or force of motion- it's a motion multiplier, and mostly affects the HIGH (but it will change the zero too). Note, if the needle gets loose and starts to flop around, you didn't break it, you just have the Span set too low. You probably want to mark one tooth on the Span and Zero before you move them, so you can keep track of what you are doing.

The gauge resistance is in the range of 12.2 to 12.8 ohms. If measured, the amperage would be somewhere around 60mA on low to 220mA on high for a single gauge. It is probably best to set temp and oil using 50, 26, and 16 ohm resistors, and fuel using 78, 26, and 10 ohm resistors. The only difference between gauges is the scale.

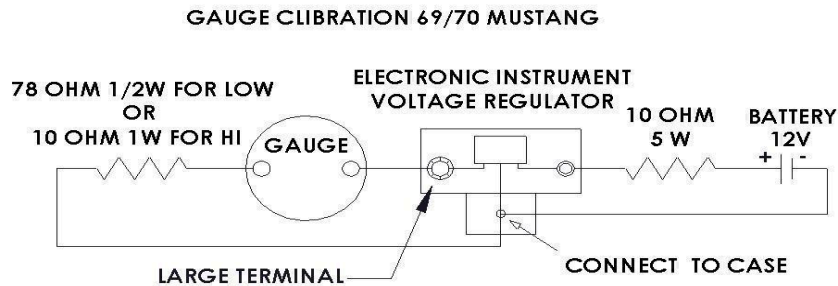

OHMS	TEMP & OIL	FUEL
78	LO	E
50	NORMAL LO	
26	MED	1/2
16	NORMAL HI	
10	HI	F

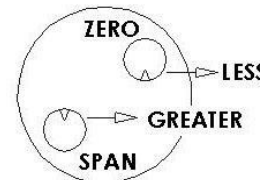
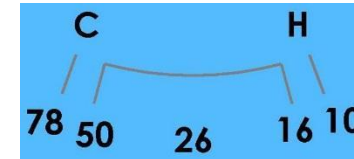

Chassis Grounds

As more and more accessories are added to older cars- like big radios, electric fuel pumps, EFI, and especially electric radiator fans and power windows, the load increases on the chassis ground system; particularly the **Chassis Ground Strap**. The best way to check the strap is with a voltage drop test. An ohmmeter really isn't useful in this case, because with an ohmmeter it would test "good" if only one wire strand was still connected. To do the test, make certain the battery is fully charged, turn on some big loads, like the head lights, the heater motor, open a door so the interior lights come on, and whatever else you may have. Don't bother cranking the engine, because it isn't in that circuit. Set the voltmeter to read 12vdc and connect it to each side of the ground strap (described on the next page). Connecting to any chassis point and the engine should suffice. Like anything else, people will have varying opinions; a voltage drop of less than 0.1 is ideal, while most will agree that 0.2 is also acceptable. I go with 0.2v and with anything more and you should clean the attachment points and tighten-up the bolts. If that doesn't work, replace the strap. **If you have added big amp accessories, increase the strap size, or even add a second strap- you can't have too big a wire.**

Battery Cables

The cables need a voltage drop test too. Make sure the battery is fully charged, connect the voltmeter to the negative battery post, the other end to the engine block, remove the coil to distributor high voltage wire, and crank the engine. You should read no more than 0.2v. Connect the voltmeter from battery positive to the solenoid left terminal and crank the engine. Again, no more than 0.2v. Clean and tighten cable ends or replace cables as required.

We will test non-tach cars first, then move on to the tach cars.

69/70 MUSTANG GAUGES
DASH WITH AMMETER AND NO TACH

CHASSIS GROUND CIRCUIT

NOTE: PLUG POSITIONS 1,3,9,10,18 ARE BLANK

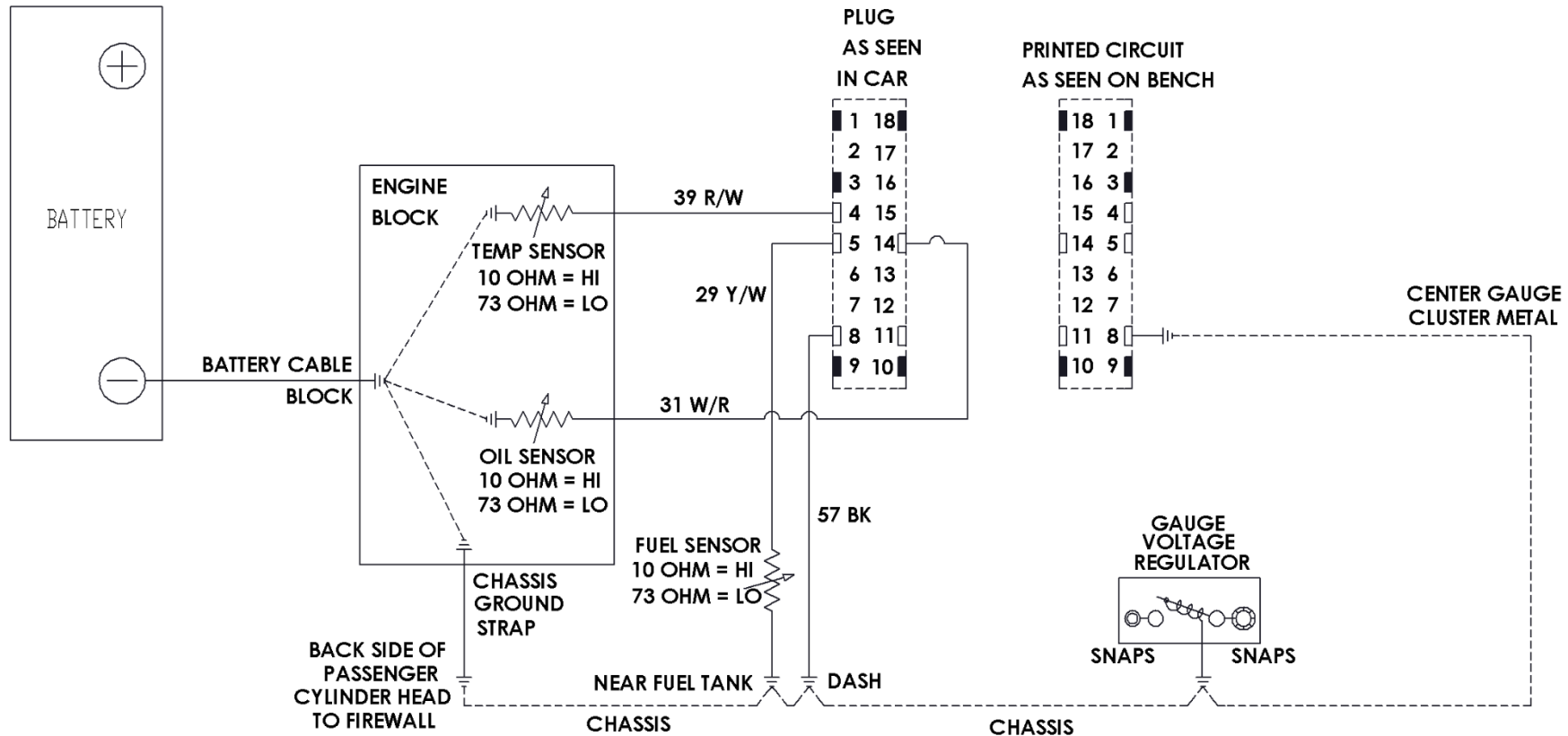

This may be the most important page in the document: Most people will overlook the ground circuit. Ford went to a lot of trouble to make sure that this circuit had adequate grounds. Notice that the negative battery cable attaches to the block, but without the Chassis Ground Strap there is no assured path from the engine to the chassis. This strap should be attached from the back side of the passenger cylinder head and connect to the firewall below the shock tower brace. The motor and transmission mounts are rubber. Without the Chassis Ground Strap, you would be relying on the linkages and drive shaft for grounds. This can cause some really nasty fires when undersized ground wires that can't handle the load burn-up.

If any of these grounds fails, the circuit doesn't work: the path is from the battery negative to the block, and then to the chassis via the Chassis Ground Strap. Once on the chassis, there are multiple connections that could fail: chassis to fuel sensor, chassis to plug pin 8, chassis to gauge voltage regulator, and on the flex circuit from pin 8 to the ground screw in the center metal housing. Although it is not shown here for simplicity sake, pin 8 on the flex circuit also connects to all the instrument grounds, including all eight Dash Back Lights, the High Beam light, the RH Turn light, and LH Turn light. The panel is also attached to the dash with two screws on top, providing yet another ground path. **Again, if you have increased the number of loads, or the amount of amps consumed by the alternator (for whatever reason), you should also increase the size or number of Chassis Ground Straps.**

This is the entire three gauge circuit for a non-tach car. It may be a little intimidating, so on the next page we will take it one gauge at a time:

69/70 MUSTANG GAUGES
DASH WITH AMMETER AND NO TACH

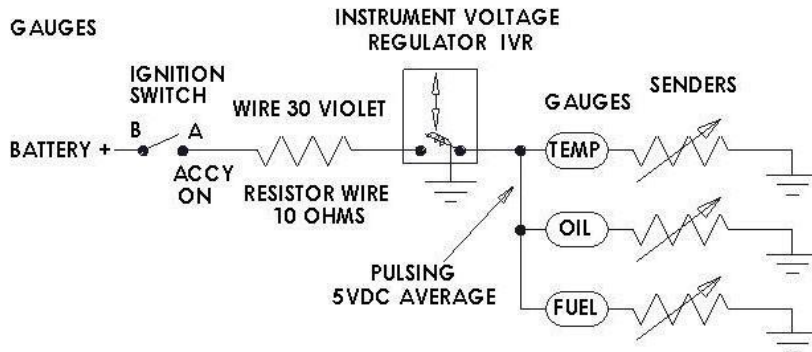
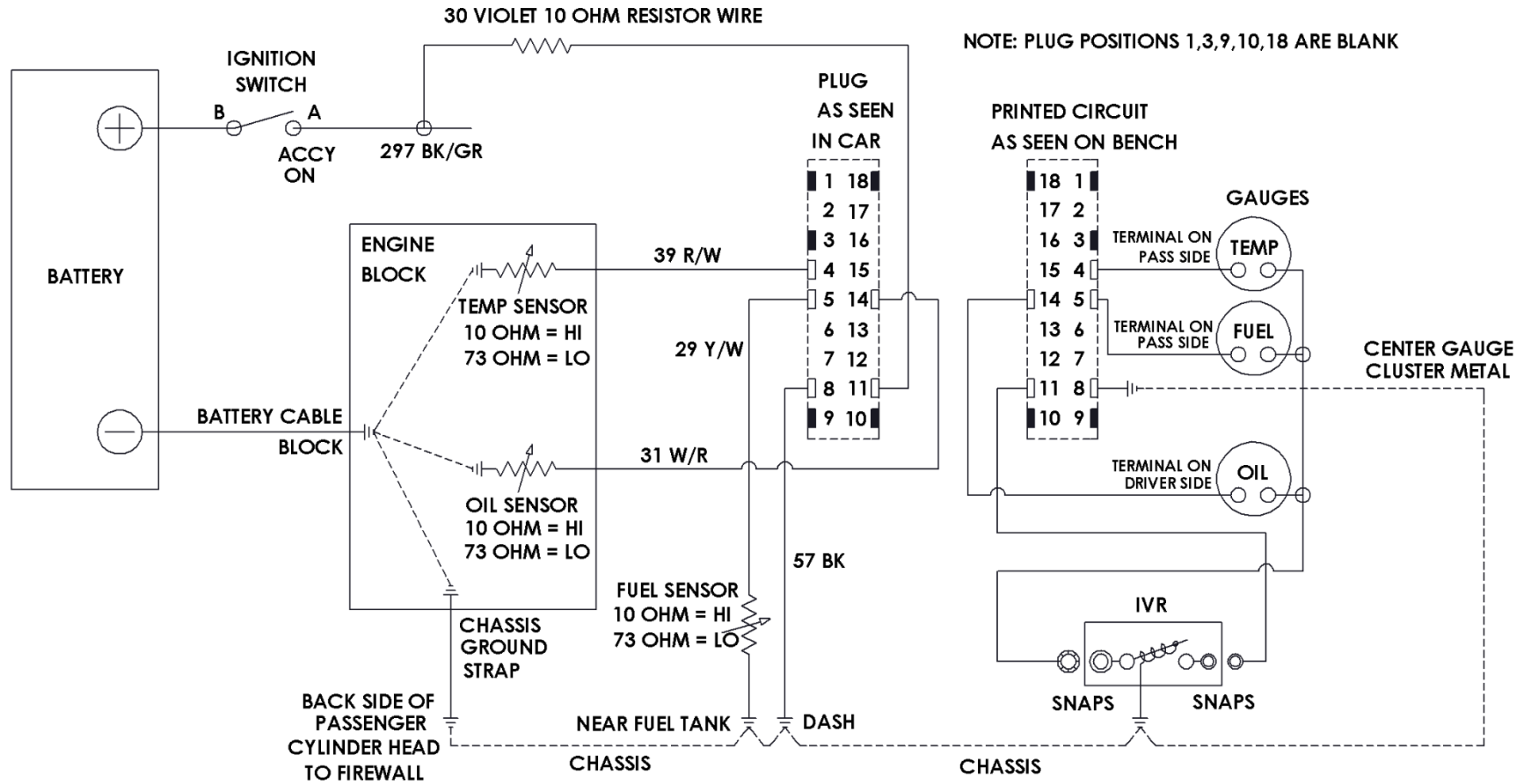

The circuit above is shown in WIRE DIAGRAM form. This is the same circuit shown above but in SCHEMATIC form, which is much easier to understand, since it is greatly simplified. However, schematics don't usually show the plugs or wire colors, so you may have trouble identifying "where you are" in the circuit when trying to compare it to the car. For that reason you may need both the wire diagram and schematic.

69/70 MUSTANG GAUGES
DASH WITH AMMETER AND NO TACH

TEMP GAUGE CIRCUIT

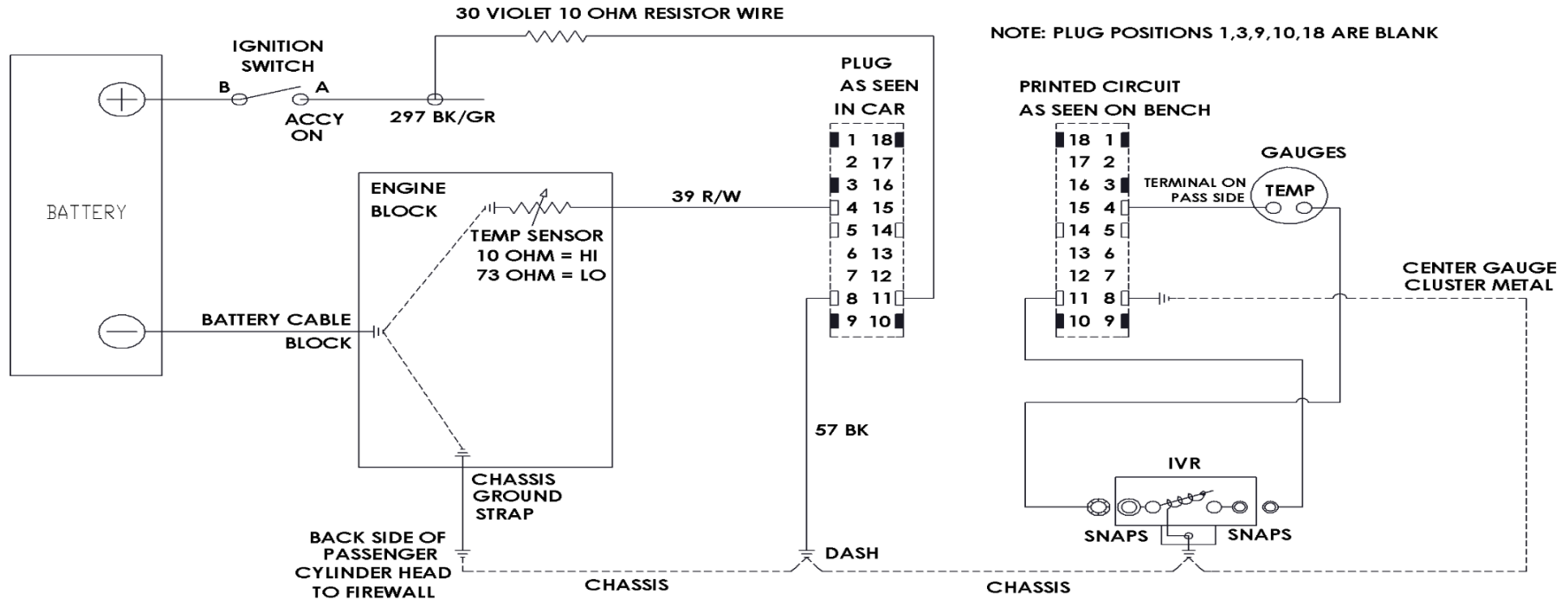

POWER COMES FROM BATTERY +, THROUGH THE IGNITION SWITCH, VIA THE 10 OHM WIRE TO PLUG 11, TO THE IVR. THE REGULATOR'S RETURN PATH IS THROUGH IT'S MOUNTING SCREW IN THE CENTER GAUGE PANEL, WHICH IS A CHASSIS GROUND THAT MAKES ITS WAY BACK TO THE BATTERY NEGATIVE TERMINAL. THE OTHER TERMINAL ON THE IVR GOES TO THE TEMP GAUGE. FROM THERE IT GOES TO PLUG 4 AND TO THE TEMP SENSOR IN THE BLOCK, AND FROM THERE BACK TO THE BATTERY NEGATIVE. THE TEMP SENSOR IS A VARIABLE RESISTOR THAT HAS 10 OHMS ON HI AND 73 OHMS ON LOW.

Use an ohmmeter and test your instrument cluster on the work bench. In tests 1, 2, 4, 6, 7, and 9, lower resistance is better, but this is mostly just a continuity check. The circuit paths on the flex should be just a few tenths of an ohm, but getting a good connection to the ohmmeter is difficult. Use Brasso and a Q-Tip to clean the copper. **Regardless, an open circuit is a failure.** Before starting you must perform the test on page 3: Gauge Posts Shorting to Metal Housing

- (1) Check for continuity from 11 to the IVRs driver side small terminal. You can unsnap it and check on the flex circuit if needed.
- (2) The IVR should have conductivity from terminal to terminal. This test is for an OEM regulator, not an aftermarket replacement. On a 50 year old part, the switch contacts can have oxidation that an ohmmeter test can't break through. You may need to run the IVR as shown on page 4 and recheck for continuity.
- (3) Test from IVR passenger side large terminal to the center metal housing. This measures the regulator's heater resistance and should be from around 56 to 61 ohms.
- (4) Check from IVR passenger side large terminal to temp gauge drivers side terminal for continuity.
- (5) Check from temp gauge terminal to terminal- it should be around 12.5 ohms.
- (6) Test temp gauge passenger side terminal to plug 4 for continuity.
- (7) Check plug 8 to center housing for continuity.
- (8) Now test the plug in the car, plug 4 to chassis. This should give you a number between 10 and 73 ohms. If the engine is cold it should be around 73 ohms. If it is appreciably higher, check the chassis ground strap and wire 57 to chassis (see page 8), or you may have a bad or incorrect sensor (like I did).
- (9) Check resistance from car plug 8 to chassis for continuity.
- (10) Set the meter to measure 12vdc and connect from car plug 11 to chassis. Make sure the plug terminals don't touch the chassis (I wrapped a towel around it), connect the battery and turn the key to ON. It should measure 12v.

69/70 MUSTANG GAUGES
DASH WITH AMMETER AND NO TACH

FUEL GAUGE CIRCUIT

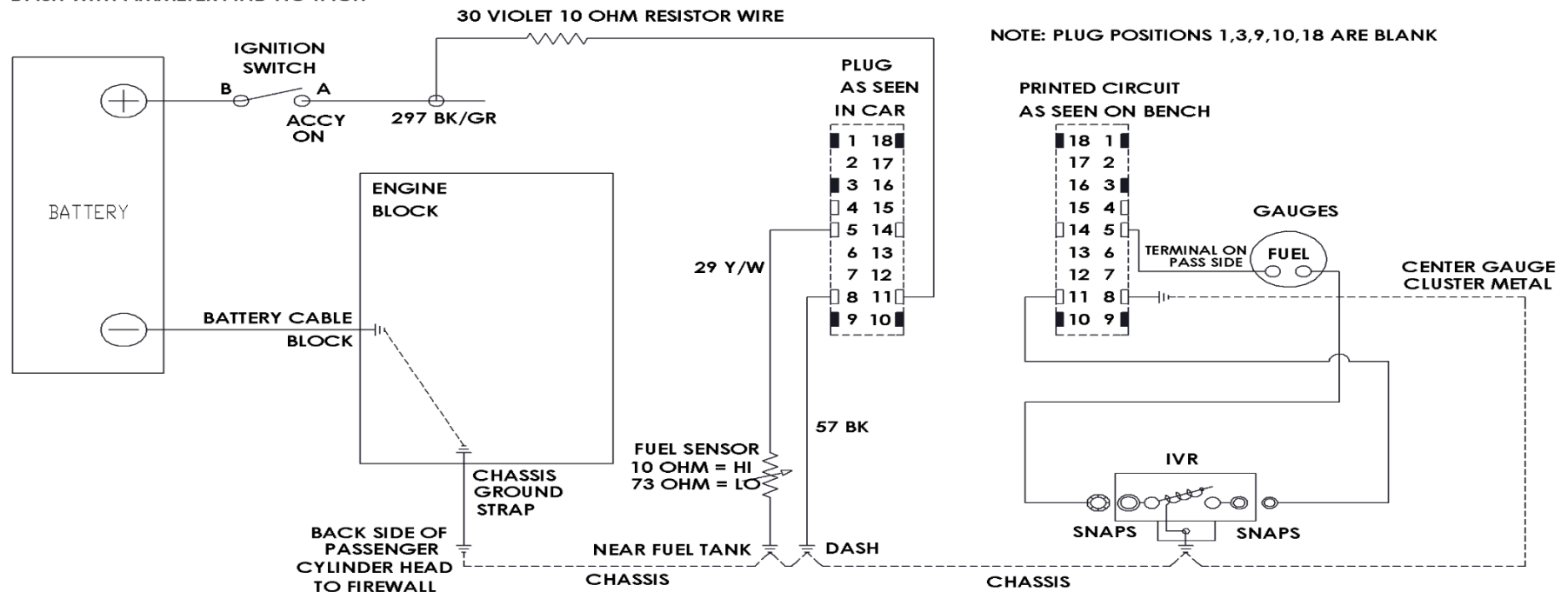

POWER COMES FROM BATTERY +. THROUGH THE IGNITION SWITCH, VIA THE 10 OHM WIRE TO PLUG 11. TO THE IVR. THE REGULATOR'S RETURN PATH IS THROUGH IT'S MOUNTING SCREW IN THE CENTER GAUGE PANEL, WHICH IS A CHASSIS GROUND THAT MAKES ITS WAY BACK TO THE BATTERY NEGATIVE TERMINAL. THE OTHER TERMINAL ON THE IVR GOES TO THE FUEL GAUGE. FROM THERE IT GOES TO PLUG 5 AND TO THE FUEL SENSOR IN THE TANK, AND FROM THERE BACK THRU CHASSIS TO THE BATTERY NEGATIVE. THE FUEL SENSOR IS A VARIABLE RESISTOR THAT HAS 10 OHMS ON HI AND 73 OHMS ON LOW.

Use an ohmmeter and test your instrument cluster on the work bench. In tests 1, 2, 4, 6, 7, and 9, lower resistance is better, but this is mostly just a continuity check. The circuit paths on the flex should be just a few tenths of an ohm, but getting a good connection to the ohmmeter is difficult. Use Brasso and a Q-Tip to clean the copper. **Regardless, an open circuit is a failure.** Before starting you must perform the test on page 3: Gauge Posts Shorting to Metal Housing

- (1) Check for continuity from 11 to the IVRs driver side small terminal. You can unsnap it and check on the flex circuit if needed.
- (2) The IVR should have conductivity from terminal to terminal. This test is for an OEM regulator, not an aftermarket replacement. On a 50 year old part, the switch contacts can have oxidation that an ohmmeter test can't break through. You may need to run the IVR as shown on page 4 and recheck for continuity.
- (3) Test from IVR passenger side large terminal to the center metal housing. This measures the regulator's heater resistance and should be from around 56 to 61 ohms
- (4) Test from IVR passenger side large terminal to fuel gauge driver's side terminal for continuity.
- (5) Check from fuel gauge terminal to terminal- it should have around 12.5 ohms.
- (6) Test fuel gauge passenger side terminal to plug 5 for continuity.
- (7) Check plug 8 to center housing for continuity.
- (8) Now test the plug in the car, plug 5 to chassis. This should give you a number between 10 and 73 ohms. If it is appreciably higher, check the chassis ground strap and wire 57 to chassis (see page 8), or you may have a bad sensor.
- (9) Check resistance from car plug 8 to chassis for continuity.
- (10) Set the meter to measure 12vdc and connect from car plug 11 to chassis. Make sure the plug terminals don't touch the chassis (I wrapped a towel around it), connect the battery and turn the key to ON. It should measure 12v.

69/70 MUSTANG GAUGES
DASH WITH AMMETER AND NO TACH

OIL GAUGE CIRCUIT

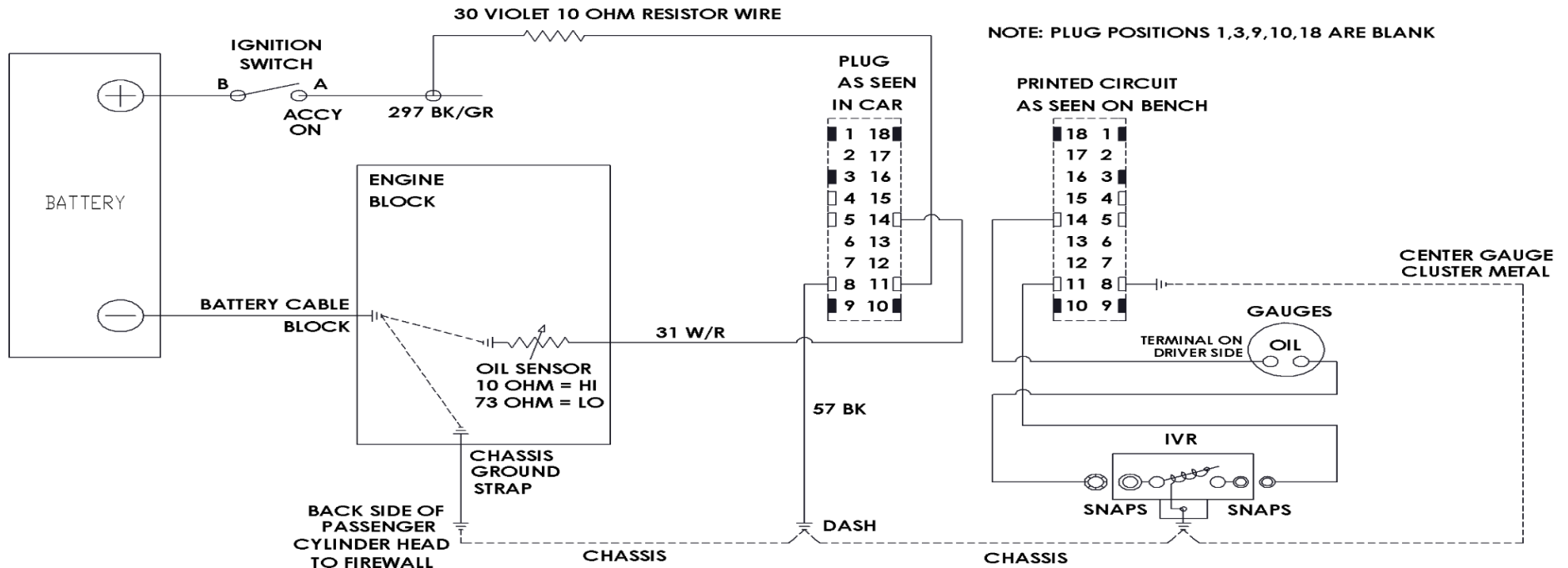

POWER COMES FROM BATTERY +, THROUGH THE IGNITION SWITCH, VIA THE 10 OHM WIRE TO PLUG 11, TO THE IVR. THE REGULATOR'S RETURN PATH IS THROUGH IT'S MOUNTING SCREW IN THE CENTER GAUGE PANEL, WHICH IS A CHASSIS GROUND THAT MAKES ITS WAY BACK TO THE BATTERY NEGATIVE TERMINAL. THE OTHER TERMINAL ON THE IVR GOES TO THE OIL GAUGE. FROM THERE IT GOES TO PLUG 14 AND TO THE OIL SENSOR IN THE BLOCK, AND FROM THERE BACK TO THE BATTERY NEGATIVE. THE OIL SENSOR IS A VARIABLE RESISTOR THAT HAS 10 OHMS ON HI AND 73 OHMS ON LOW.

Use an ohmmeter and test your instrument cluster on the work bench. In tests 1, 2, 4, 6, 7, and 9, lower resistance is better, but this is mostly just a continuity check. The circuit paths on the flex should be just a few tenths of an ohm, but getting a good connection to the ohmmeter is difficult. Use Brasso and a Q-Tip to clean the copper. **Regardless, an open circuit is a failure.** Before starting you must perform the test on page 3: Gauge Posts Shorting to Metal Housing

- (1) Check for continuity from 11 to the IVR's driver side small terminal. You can unsnap it and check on the flex circuit if needed.
- (2) The IVR should have conductivity from terminal to terminal. This test is for an OEM regulator, not an aftermarket replacement. On a 50 year old part, the switch contacts can have oxidation that an ohmmeter test can't break through. You may need to run the IVR as shown on page 4 and recheck for continuity.
- (3) Test from IVR passenger side large terminal to the center metal housing. This measures the regulator's heater resistance and should be from around 56 to 61 ohms
- (4) Test from IVR passenger side large terminal to oil gauge driver's side terminal for continuity.
- (5) Check from oil gauge terminal to terminal- it will have around 12.5 ohms.
- (6) Test oil gauge driver's side terminal to plug 14 for continuity.
- (7) Check plug 8 to center housing for continuity.
- (8) Now test the plug in the car, plug 14 to chassis. This should give you a number between 10 and 73 ohms. Since the engine will be off it should be around 73 ohms. If it is appreciably different, check the chassis ground strap and wire 57 to chassis (see page 8), or you may have a bad sensor.
- (9) Check resistance from car plug 8 to chassis for continuity.
- (10) Set the meter to measure 12vdc and connect from car plug 11 to chassis. Make sure the plug terminals don't touch the chassis (I wrapped a towel around it), connect the battery and turn the key to ON. It should measure 12v.

**69/70 MUSTANG "EVERYTHING ELSE"
DASH WITH AMMETER AND NO TACH**

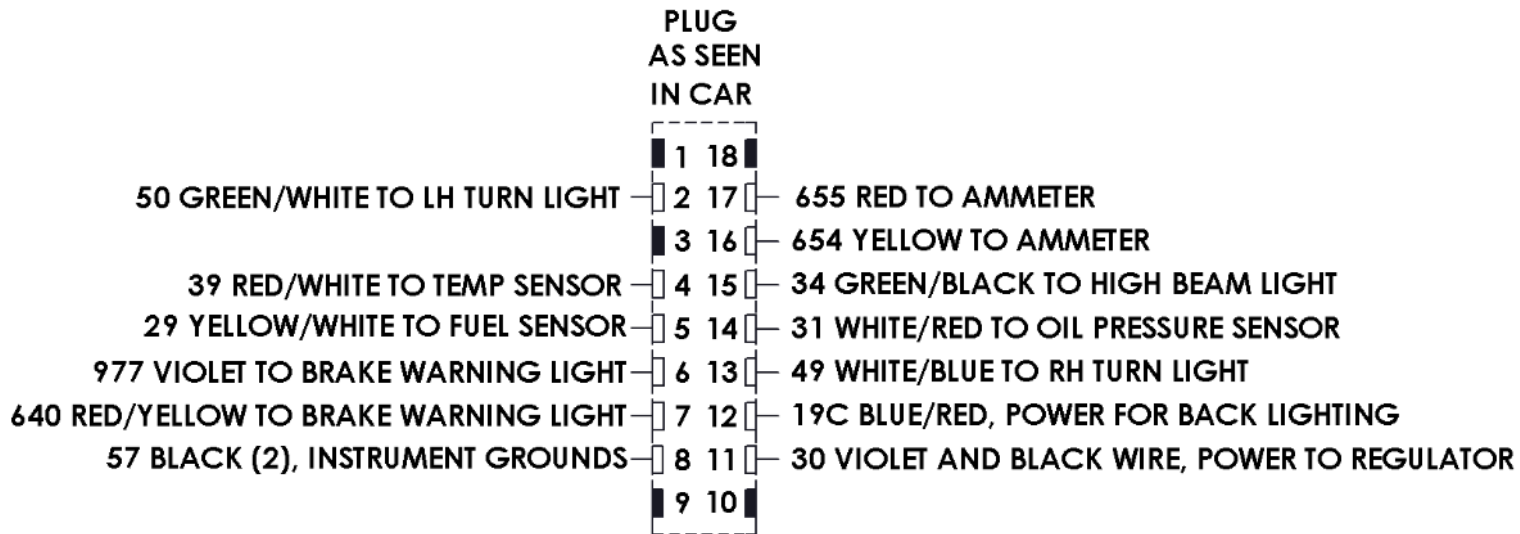

As you can see, this shows all the wires that go into the plug in the car, and 1, 3, 9, 10, and 18 are blanks

Plug in car, testing everything else; let's start with the plug in the car, and ignore the things already tested with the gauges. We will start with the voltmeter set to measure 12vdc, make sure terminals in the plug do not touch the chassis and cause a short (I wrapped a towel around it). Connect battery, key on:

- (1) Connect to pin 2 with one lead and to chassis with the other, turn on LH blinker, should get 12v blinking.
 - (2) Connect to pin 7 and to chassis, 12v
 - (3) Connect to pin 12 and to chassis, turn lights on, and turn knob. Voltage should increase to 12v when CCW, and lower when going CW.
 - (4) Connect to pin 13 and to chassis, turn on RH blinker, should get 12v blinking
 - (5) Connect to pin 15 and to chassis, turn on lights and high beams, should get 12v
 - (6) Connect to pin 16 and to chassis, 12v. Also see Ammeter section
 - (7) Connect to pin 17 and to chassis, 12v. Also see Ammeter section
- Turn everything off and disconnect battery, set meter to read ohms;
- (8) Connect to pin 6 and to chassis, turn key to Start. This connects the "prove-out" circuits, you should get continuity as long as key is in Start. I got 50 to 80 ohms, but less is better.
 - (9) Connect to pin 8 and to chassis, you should get continuity.

This is for a non-tach car, and shows everything else that goes on in the cluster

NOTE: PLUG POSITIONS 1,3,9,10,18 ARE BLANK

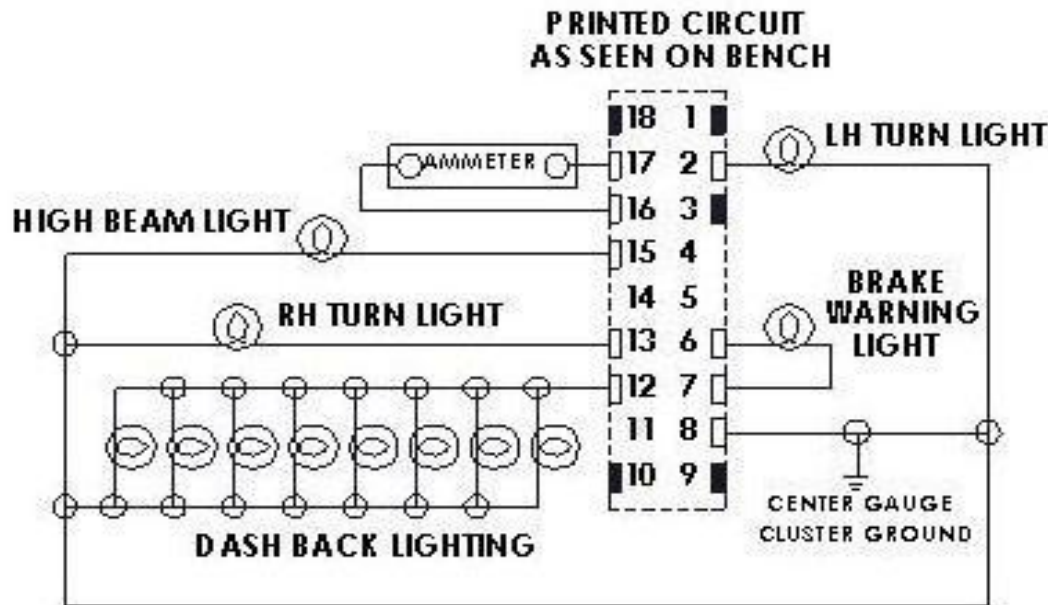

Cluster on bench, testing everything else:

Use ohmmeter and clamp to center housing metal, then touch to these other points, looking for continuity in all these places. **An open circuit is a failure:**

- (1) Connect to pin 2 and center housing. Tests LH turn light, should get continuity.
 - (2) Connect to pin 8 and at center housing. Tests flex path for continuity.
 - (3) Find flex ground screw in picture on page 2, #7, connect there and at center housing for continuity.
 - (4) With one probe clamped to center housing, touch all eight dash back lights for continuity- if you don't get it on one side of the socket, try the other.
 - (5) Connect to pin 13 and center housing. Tests RH turn light for continuity.
 - (6) Connect to pin 15 and center housing. Tests high beam light for continuity.
- Unclamp from the metal housing and connect probes as instructed:
- (7) Connect to pins (6) and (7). This tests the Brake warning light for continuity.
 - (8) Connect to pins (16) and (17). This tests for continuity through ammeter and should be in the 0.3 to 0.5 ohm range. Also see Ammeter section below.

Ammeter (well...sort of)

This device is technically known as a Galvanometer. A **galvanometer** shows the **direction** that current flows in a circuit whereas an **ammeter** only measures the **amount** of the current that flows through it. By the way, Ford never actually called it an ammeter- the gauge says "ALTERNATOR". So why did Ford use a galvanometer instead of an ammeter? Because they're cheap. These cars cost about a dollar a pound, and in an effort to keep it that way, they cut corners wherever they could. Some cars of the era (Chrysler products) used actual ammeters. They were positioned between the ammeter and the alternator, and all the power in the car was routed through them. This meant that a very large and expensive copper wire had to run from the alternator to the gauge, and all the way back to the battery. If the ammeter went out, nothing in the car worked.

It seems that most everyone complains about our "ammeters". I have had my car since it was new, and I don't ever remember it working, or if it did, it deflected so little that it went unnoticed. The galvanometer has a couple of advantages over an actual ammeter: **if** the galvanometer goes out, the car still runs, and it doesn't cost as much. On the down side, it doesn't seem to do anything.

When working, the galvanometer diverts a tiny amount of current **around** wire 38A (see below) and into the galvanometer to show the direction the current is flowing and it gives an **impression** of how much. Wire 38A is a 12ga. black wire that is 22" long and is positioned between the alternator and the battery so as the battery charges or discharges it registers on the galvanometer.

The problem is usually one of two things- the gauge has self-destructed (a continuity test will tell you that), or there is high resistance on wires 654 and 655, usually at the firewall plug, but it could also be at the flex plug, or the nut and washer connection of the ammeter to the flex. There is a possibility it could also be the connection of wire 38 B to the left starter solenoid post. Clean all the connections with Brasso, a toothbrush and a Q-Tip. Some people say to then use Ford silicone dielectric grease D7AZ-19A331-A, because it will keep the water and corrosion out.

Now here is the bad part; if you have upgraded to a 3G or newer alternator, the ammeter won't work anyway, since wire 38A won't be the correct gauge or length. To make matters worse, most people unknowingly bypass the ammeter by connecting the new alternator to the left starter solenoid post via a big fuse. And it makes perfect sense to do so for a number of reasons.

For the reasons listed above, it may be better to have the "ammeter" converted to a conventional voltmeter so it can actually give useful information. There are several shops that will do this, Rocketman's Classic Cougar Innovations is one example. They use the existing scale so it looks stock. The only visual difference is that the needle goes to the left when off, instead of center. Circuit connections will need to change, and they say "You may have to use a razor blade or knife to cut the printed

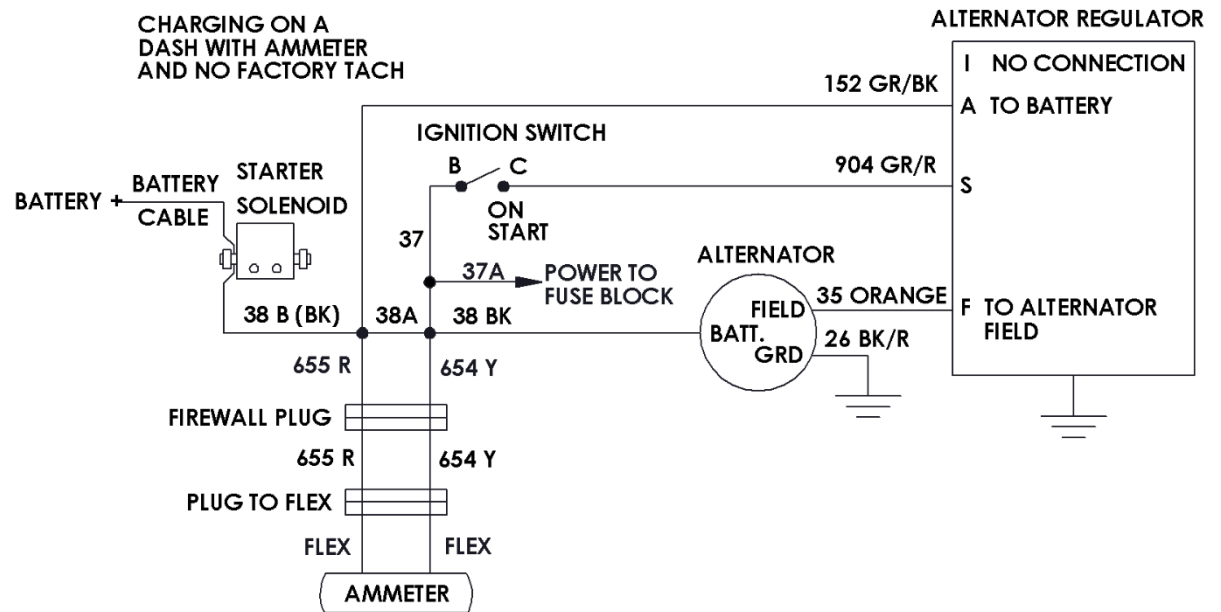

circuit around the ammeter connections". Instead, I would make the changes to the wires in the car at plug 16 and 17 and leave the flex circuit alone.

I know of at least one person (Ivy66GT on All Ford Mustangs.com) that increased the sensitivity of his galvanometer. He increased the length of wire 38A by I believe an additional 44" to give it more resistance. He did this to a 66. In this circuit wire 38A is known as the **shunt**. It diverts (shunts) almost all of the current around the galvanometer. If you increase the shunts resistance, then more current has to flow through the galvanometer. This gives the galvanometer more deflection or range of motion (wiggle) for a given amount of amp draw, and makes it seem like its doing something. *But*, you must have the alternator connected in the stock configuration as shown above. When his turn signals "blinked", he was able to see it deflect the ammeter, ahhh galvanometer.

Testing cars with tachometer

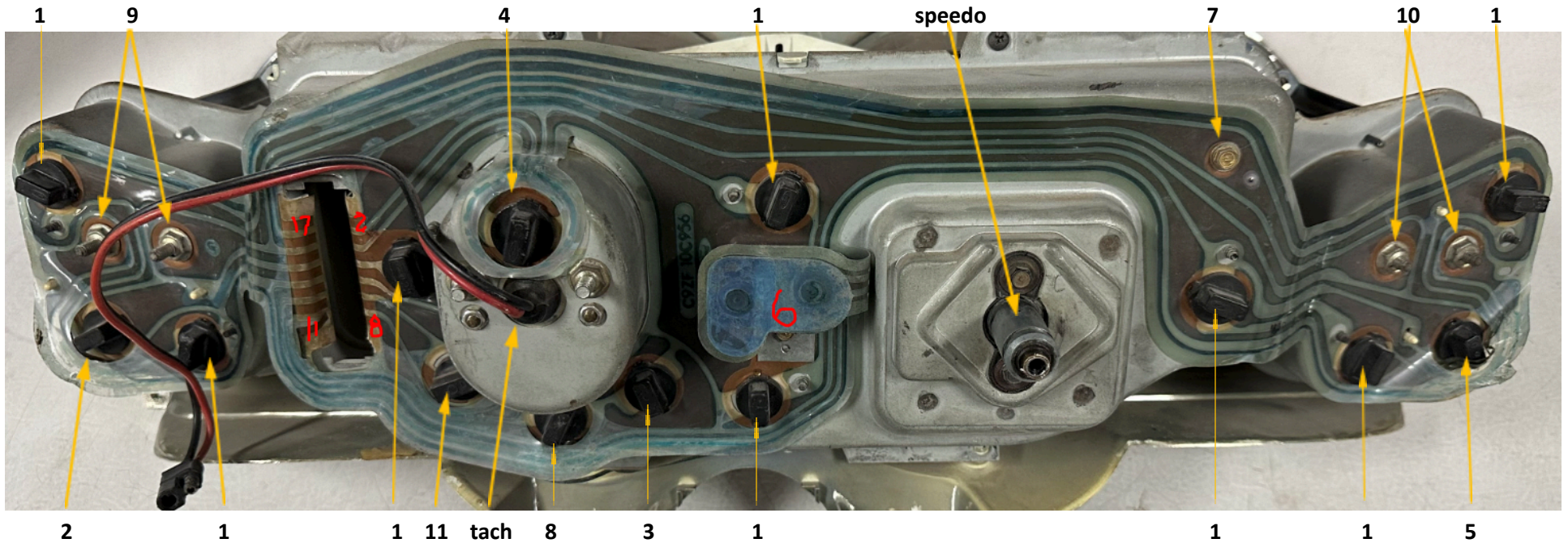

1's are the backlights- there are eight of them.

2 right hand turn indicator light

3 brake warning light

4 high beam indicator light

5 left hand turn indicator light

6 Gauge Constant Voltage Regulator. Also known as IVR instrument voltage regulator.

You can see the attachment screw below the 6. This screw holds the regulator in place **and** gives it an electrical connection to chassis ground- without which it would not operate.

7 is one of the chassis grounds that allows the regulator to operate. It grounds the center metal housing. The right and left gauge clusters are not grounded.

8 Oil light

9 fuel gauge terminals

10 temperature gauge terminals

11 alternator light

69/70 MUSTANG GAUGES
DASH WITH TACHOMETER

CHASSIS GROUND CIRCUIT

NOTE: PLUG POSITIONS 1,9,10,18 ARE BLANK

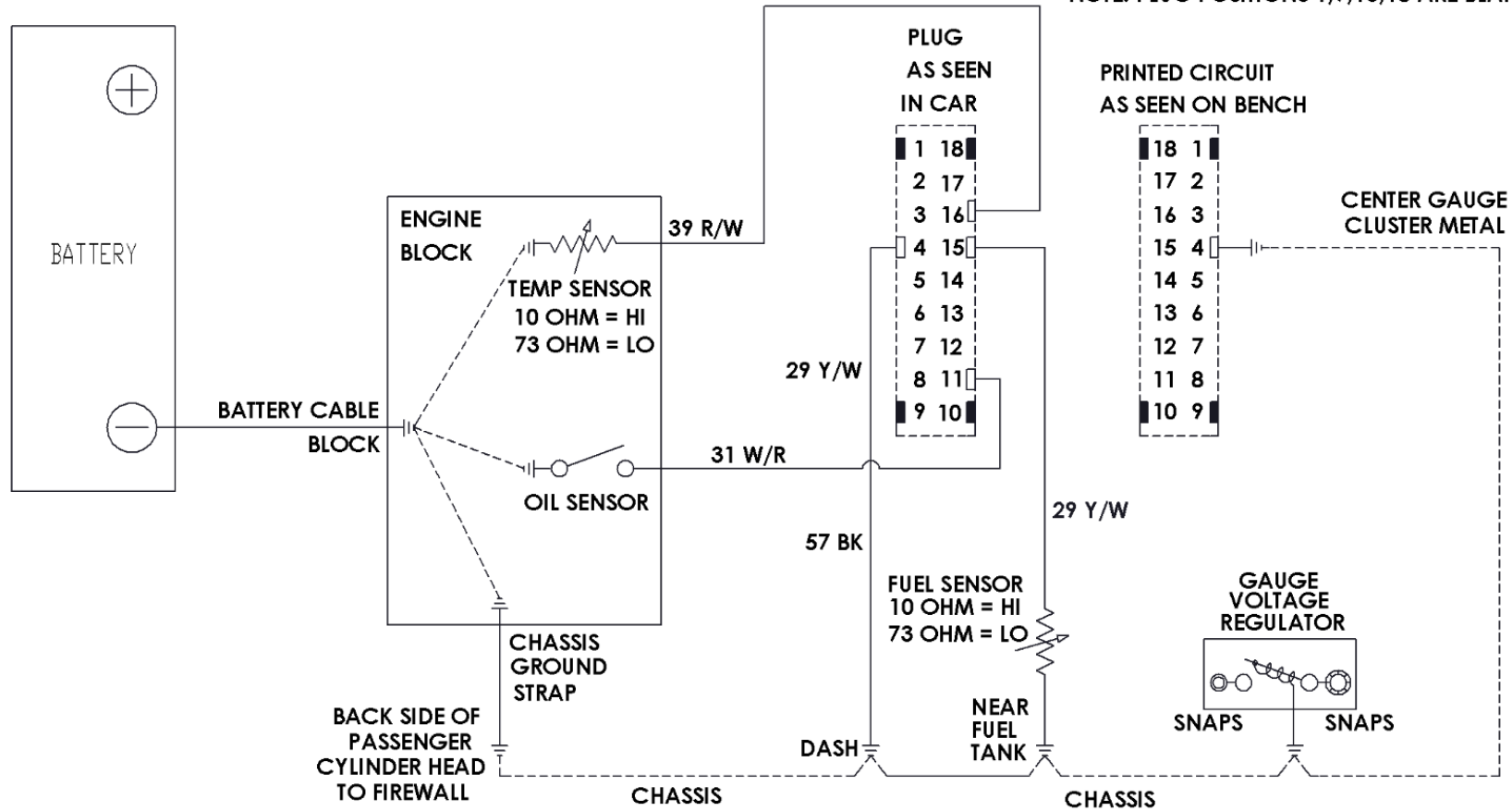

MOST PEOPLE WILL OVERLOOK THE GROUND CIRCUIT. FORD WENT TO A LOT OF TROUBLE TO MAKE SURE THAT THE CIRCUIT HAD ADEQUATE GROUNDS. NOTICE THAT THE NEGATIVE BATTERY CABLE ATTACHES TO THE BLOCK, BUT WITHOUT THE CHASSIS GROUND STRAP THERE IS NO ASSURED PATH FROM THE ENGINE TO THE CHASSIS. IT SHOULD BE ATTACHED FROM THE BACK SIDE OF THE PASSENGER CYLINDER HEAD TO THE FIREWALL JUST BELOW THE SHOCKTOWER BRACE. THE MOTOR AND TRANSMISSION MOUNTS ARE RUBBER. WITHOUT THE CHASSIS GROUND STRAP, YOU WOULD BE RELYING ON THE LINKAGES AND DRIVE SHAFT FOR GROUNDS. THIS CAN CAUSE SOME REALLY NASTY FIRES WHEN UNDERSIZED GROUND WIRES THAT CAN'T HANDLE THE LOAD BURN-UP.

IF ANY ONE OF THESE GROUNDS FAILS, THE CIRCUIT DOESN'T WORK: THE PATH IS FROM BATTERY NEGATIVE TO THE BLOCK, AND THEN TO THE CHASSIS VIA THE GROUND STRAP. ONCE ON THE CHASSIS THERE ARE MULTIPLE CONNECTIONS THAT COULD FAIL: CHASSIS TO FUEL SENSOR, CHASSIS TO PLUG PIN 4, CHASSIS TO VOLTAGE REGULATOR, AND ON THE FLEX CIRCUIT FROM PIN 4 TO THE GROUND SCREW ON THE CENTER METAL HOUSING. ALTHOUGH IT IS NOT SHOWN HERE, PIN 4 ON THE FLEX CIRCUIT ALSO CONNECTS TO ALL THE INSTRUMENT GROUNDS, INCLUDING ALL DASH BACK LIGHTS, THE HIGH BEAM LIGHT, RH TURN LIGHT, THE OIL LIGHT, AND LH TURN LIGHT. THE PANEL IS ALSO ATTACHED TO THE DASH WITH TWO SCREWS ON TOP, PROVIDING ANOTHER GROUND PATH.

69/70 MUSTANG GAUGES
DASH WITH TACHOMETER

TEMP GAUGE CIRCUIT

NOTE: PLUG POSITIONS 1,9,10,18 ARE BLANK



Use an ohmmeter and test your instrument cluster on the work bench. In tests 1, 2, 4, 6, 7, and 9, lower resistance is better, but this is mostly just a continuity check. The circuit paths on the flex should be just a few tenths of an ohm, but getting a good connection to the ohmmeter is difficult. Use Brasso and a Q-Tip to clean the copper. **Regardless, an open circuit is a failure.** Before starting you must perform the test on page 3: Gauge Posts Shorting to Metal Housing

- (1) Check for continuity from pin 13 to the IVRs driver side small terminal. You can unplug it and check on the flex circuit if needed.
- (2) The IVR should have conductivity from terminal to terminal. This test is for an OEM regulator, not an aftermarket replacement. On a 50 year old part, the switch contacts can have oxidation that an ohmmeter test can't break through. You may need to run the IVR as shown on page 4 and recheck for continuity.
- (3) Test from IVR passenger side large terminal to the center metal housing. This measures the regulator's heater resistance and should be from around 56 to 61 ohms.
- (4) Check from IVR passenger side large terminal to temp gauge drivers side terminal for continuity.
- (5) Check from temp gauge terminal to terminal- it should be around 12.5 ohms.
- (6) Test temp gauge passenger side terminal to plug 16 for continuity.
- (7) Check plug 4 to center housing for continuity.
- (8) Now test the plug in the car, plug 16 to chassis. This should give you a number between 10 and 73 ohms. If the engine is cold it should be around 73 ohms. If it is appreciably higher, check the chassis ground strap and wire 57 to chassis, or you may have a bad or incorrect sensor (like I did).
- (9) Check resistance from car plug 4 to chassis for continuity.
- (10) Set the meter to measure 12vdc and connect from car plug 13 to chassis. Make sure the plug terminals don't touch the chassis (I wrapped a towel around it), connect the battery and turn the key to ON. It should measure 12v.

69/70 MUSTANG GAUGES
DASH WITH TACHOMETER

FUEL GAUGE CIRCUIT

NOTE: PLUG POSITIONS 1,9,10,18 ARE BLANK

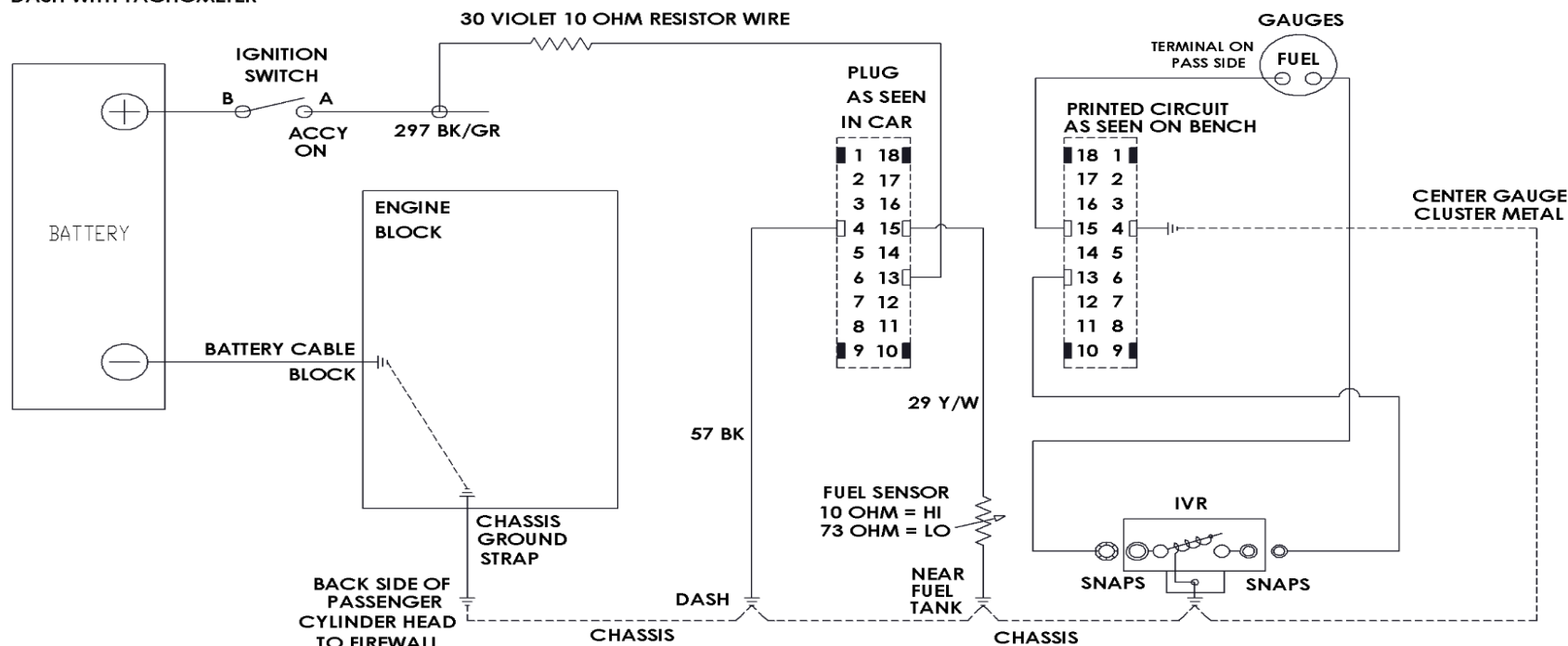

POWER COMES FROM BATTERY +, THROUGH THE IGNITION SWITCH, VIA THE 10 OHM WIRE TO PLUG 13, TO THE IVR. THE REGULATOR'S RETURN PATH IS THROUGH IT'S MOUNTING SCREW IN THE CENTER GAUGE PANEL, WHICH IS A CHASSIS GROUND THAT MAKES ITS WAY BACK TO THE BATTERY NEGATIVE TERMINAL. THE OTHER TERMINAL ON THE IVR GOES TO THE FUEL GAUGE. FROM THERE IT GOES TO PLUG 15 AND TO THE FUEL SENSOR IN THE TANK, AND FROM THERE BACK THRU CHASSIS TO THE BATTERY NEGATIVE. THE FUEL SENSOR IS A VARIABLE RESISTOR THAT HAS 10 OHMS ON HI AND 73 OHMS ON LOW.

Use an ohmmeter and test your instrument cluster on the work bench. In tests 1, 2, 4, 6, 7, and 9, lower resistance is better, but this is mostly just a continuity check. The circuit paths on the flex should be just a few tenths of an ohm, but getting a good connection to the ohmmeter is difficult. Use Brasso and a Q-Tip to clean the copper. **Regardless, an open circuit is a failure.** Before starting you must perform the test on page 3: Gauge Posts Shorting to Metal Housing

- (1) Check for continuity from 13 to the IVRs driver side small terminal. You can unsnap it and check on the flex circuit if needed.
- (2) The IVR should have conductivity from terminal to terminal. This test is for an OEM regulator, not an aftermarket replacement. On a 50 year old part, the switch contacts can have oxidation that an ohmmeter test can't break through. You may need to run the IVR as shown on page 4 and recheck for continuity.
- (3) Test from IVR passenger side large terminal to the center metal housing. This measures the regulator's heater resistance and should be from around 56 to 61 ohms
- (4) Test from IVR passenger side large terminal to fuel gauge driver's side terminal for continuity.
- (5) Check from fuel gauge terminal to terminal- it should have around 12.5 ohms.
- (6) Test fuel gauge passenger side terminal to plug 15 for continuity.
- (7) Check plug 4 to center housing for continuity.
- (8) Now test the plug in the car, plug 15 to chassis. This should give you a number between 10 and 73 ohms. If it is appreciably higher, check the chassis ground strap and wire 57 to chassis (see page 17), or you may have a bad sensor.
- (9) Check resistance from car plug 4 to chassis for continuity.

**69/70 MUSTANG GAUGES
DASH WITH TACHOMETER**

OIL LIGHT CIRCUIT

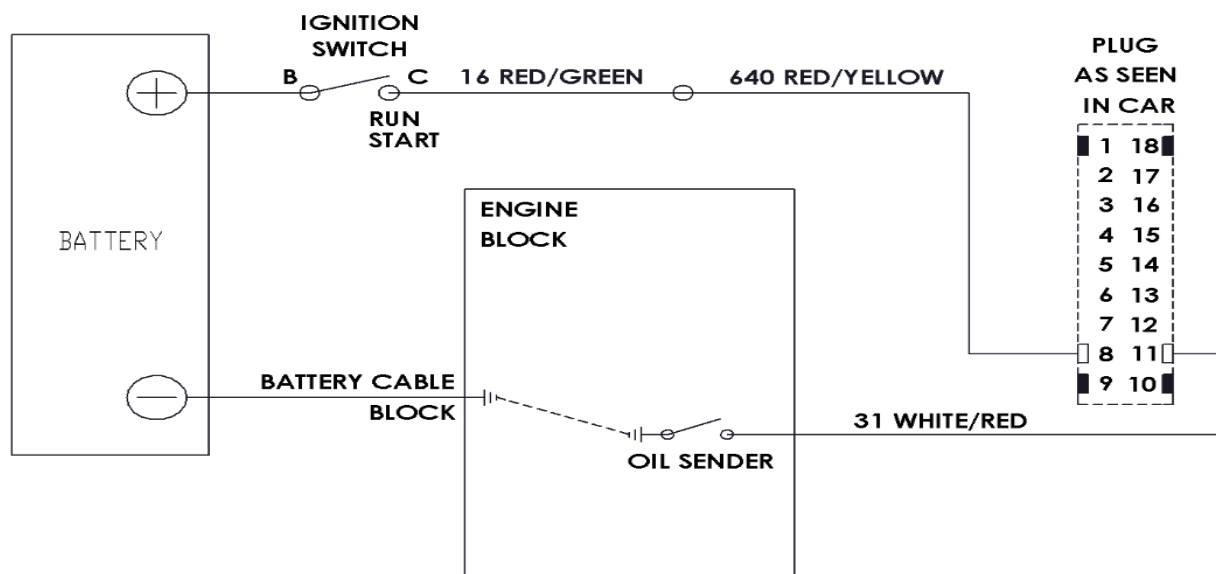

NOTE: PLUG POSITIONS 1,9,10,18 ARE BLANK

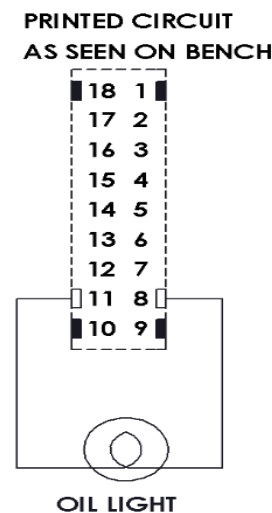

POWER COMES FROM BATTERY +, THROUGH THE IGNITION SWITCH TO PLUG 8, TO THE OIL LIGHT, TO PIN 11, AND THEN TO THE OIL SENDER IN THE BLOCK. FROM THERE IT GOES TO THE BATTERY NEGATIVE. THE OIL SENDER IS A SWITCH THAT IS CLOSED IN A LOW OIL PRESSURE CONDITION.

Use an ohmmeter and test your instrument cluster on the work bench. This is a continuity check. Getting a good connection to the ohmmeter can be difficult. Use Brasso and a Q-Tip to clean the copper. **Regardless, an open circuit is a failure.**

- (1) Check for continuity from 11 to 8. No continuity would indicate the light is faulty.

- (2) Now test the plug in the car, plug 11 to chassis. Since the engine will be off it should be shorted to chassis with very little resistance, or you may have a bad sensor.
- (3) Now set the meter to read DC volts. Make sure the plug terminals don't touch the chassis (I wrapped a towel around it), connect the battery and turn the key to ON and check from car plug 8 to chassis for 12v.

69/70 MUSTANG "EVERYTHING ELSE" DASH WITH TACHOMETER

Dash Plug as seen in car for Tach Car								
			1		18			
DASH LIGHTS	BLUE/RED	19C	2		17	50	GREEN/WHITE	LH TURN
HI BEAM	GREEN/BLACK	34	3		16	39	RED/WHITE	TEMP SENDER
GROUND	BLACK	57	4		15	29	YELLOW/WHITE	FUEL SENDER
DASH LIGHTS	BLUE/RED	19C	5		14	49	WHITE/BLUE	RH TURN
ALT WARNING LIGHT	BLACK/GREEN	30	6		13	30A/484	VIOLET & BLACK	IVR POWER
ALT WARNING LIGHT	YELLOW/BLACK	643	7		12	977	PURPLE	BRAKE WARNING
POWER TO OIL & BRAKE WARN	RED/YELLOW	640	8		11	31	WHITE/RED	OIL SENDING
			9		10			

As you can see, this shows all the wires that go into the plug in the car, and 1, 9, 10, and 18 are blanks

Plug in car, testing everything else; let's start with the plug in the car, and ignore the things already tested with the gauges. Start with the voltmeter set to measure 12vdc, make sure terminals in the plug do not touch the chassis and cause a short (I wrapped a towel around it). Connect battery, key on:

- (1) Connect to pin 2 and to chassis, turn lights on, and turn knob. Voltage should increase to 12v when CCW, and lower when going CW.
- (2) Connect to pin 3 and to chassis, turn on lights and high beams, should get 12v
- (3) Connect to pin 5 and to chassis, turn lights on, and turn knob. Voltage should increase to 12v when CCW, and lower when going CW.
- (4) Connect to Pin 8 and chassis, should get 12v.
- (5) Connect to pin 14 and to chassis, turn on RH blinker, should get 12v blinking

(6) Connect to pin 17 with one lead and to chassis with the other, turn on LH blinker, should get 12v blinking.

Turn everything off and **disconnect battery**, set meter to read ohms;

(7) Connect to pin 4 and to chassis, you should get continuity.

(8) Pins 6 and 7 are for the alternator warning light and are best tested later by starting the car and watching for the alternator light to go out when the engine is running. However, if you connect the ohmmeter from pins 6 to 7, it should read 15 ohms.

(9) Connect to pin 12 and to chassis, turn key to Start. This connects the "prove-out" circuits, you should get continuity as long as key is in Start. I got 50 to 80 ohms, but less is better.

Tested previously:

Pin 11 tested with oil light. Pin 11 to chassis should have continuity.

Pin 13 tested with fuel and temp gauges. Pin 13 to chassis, 12v with key on (power to IVR).

Pin 15 tested with fuel sender. Pin 15 to chassis 10-73 ohms depending on how much fuel is in the tank.

Pin 16 tested with temp sender. Pin 16 to chassis, around 73 ohms since engine temp sender should be cold.

TACHOMETER VERSION

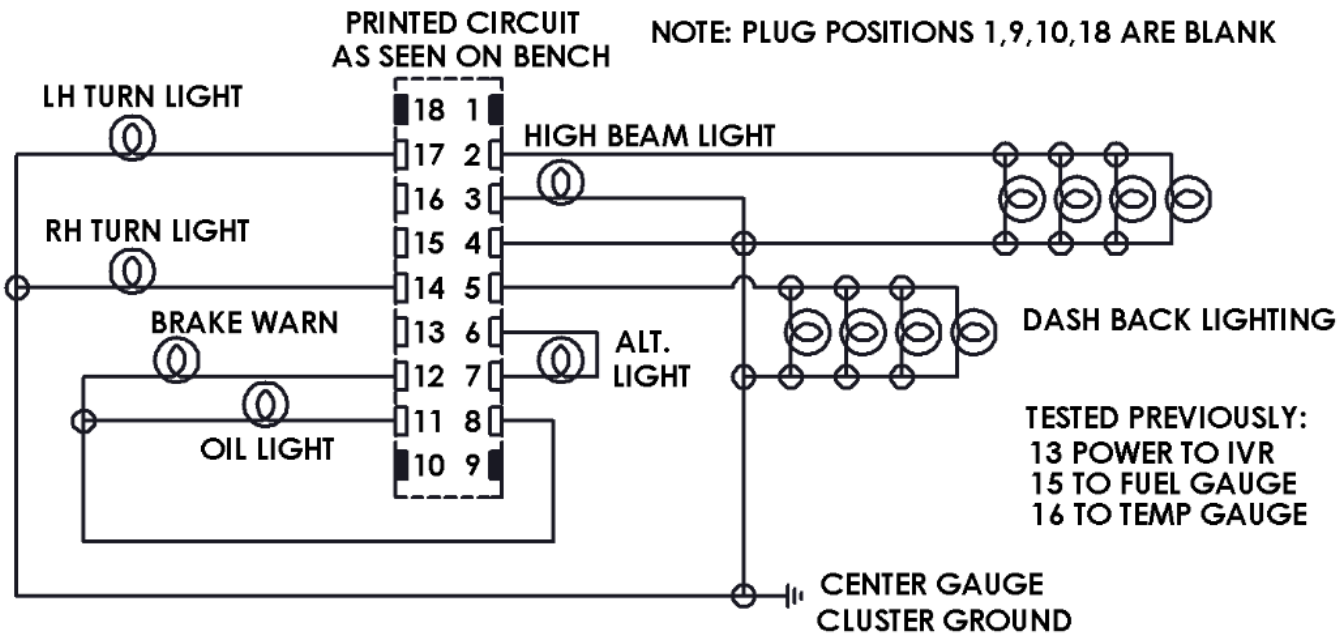

Cluster on bench, testing everything else:

Use ohmmeter and touch to these other, looking for **continuity** in all these places. **An open circuit is a failure:**

(1) With one probe clamped to center housing, touch all eight dash back lights for continuity- if you don't get it on one side of the socket, try the other.

(2) Connect to pin 2 and center housing. Tests path through Dash Back Lighting.

(3) Connect to pin 3 and center housing. Tests High Beam Light.

- (4) Connect to pin 4 and center housing. Tests Ground path.
- (5) Connect to pin 5 and center housing. Tests path through Dash Back Lighting.
- (6) Connect to pins 6 and 7. Tests Alternator Light.
- (7) Connect to pin 8 and 11. Tests Oil Light.
- (8) Connect to pin 8 and 12. Tests Brake Warning Light.
- (9) Connect to pin 4 and 14. Tests RH Turn Light.
- (10) Connect to pin 4 and 17. Tests LH Turn Light.

Fuel Level Indication System Tolerance

This is the only document found for gauge tolerance, shown in the Electrical Assembly Manual.

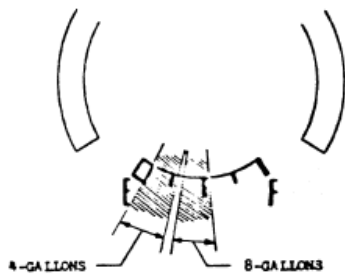

COUGAR (BASE) FUEL SYSTEM

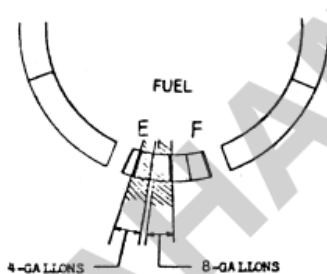

COUGAR XR-7 FUEL SYSTEM

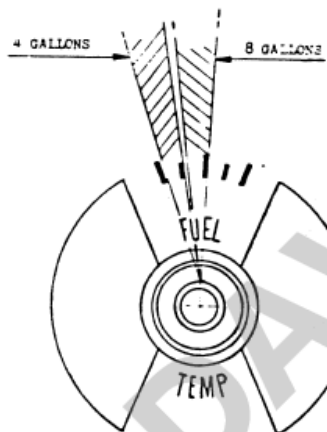

MUSTANG (BASE) FUEL SYSTEM

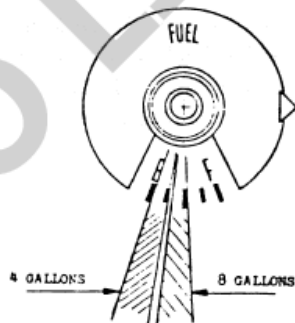

MUSTANG R.P.O. CLUSTER
FUEL SYSTEM

- NOTE:**
1. AFTER THE IGNITION SWITCH HAS BEEN "ON" A MINIMUM OF ONE (1) MINUTE, THE CENTERLINE OF POINTER MUST BE WITHIN THE SHADED AREA SHOWN FOR SPECIFIED FILL.
 2. IF THE FUEL INDICATION IS OUT OF THE TOLERANCE LIMITS SHOWN, CONTACT THE GPD RESIDENT ENGINEER OF THE INSTRUMENT CLUSTER & SYSTEMS ENGINEERING DEPARTMENT, GPD-FEO

FUEL LEVEL INDICATION SYSTEM TOLERANCE MODELS-ALL (STL. & R.P.O.)	
MUSTANG-COUGAR	K9-210-A

DATE 10-8-68 SUPERSEDES 8-7-68
EFFECTIVE WITH CXK-PP-517100
REVISED PAGE TO AGREE WITH LATEST FUEL GAUGE TOLERANCE INFORMATION